

REVISIONS				
ISS	ZONE	DESCRIPTION	PER REQUEST	DATE

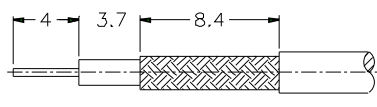

RECOMMENDED
CABLE STRIPPING DIM'S

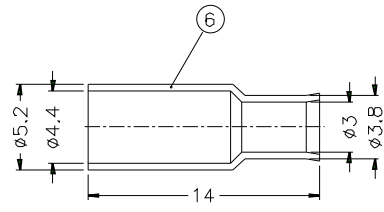
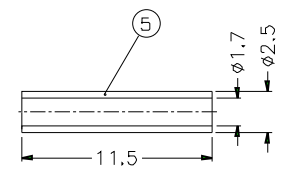
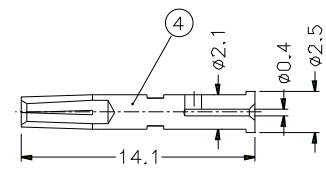
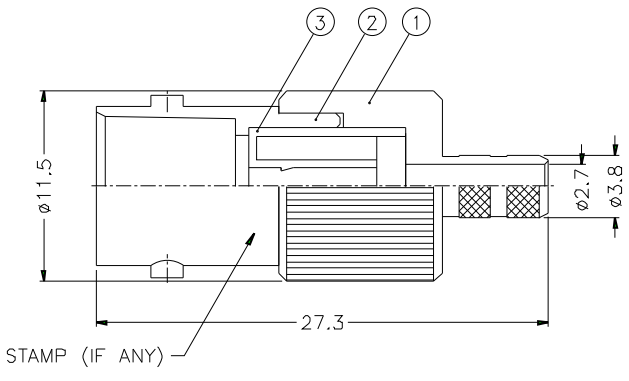

- NOTES: FINISH (PLATING THICKNESS IN MICRO-INCHES)
1. BRASS PER QQ-B-626
 2. NICKEL PL., 100 MIN. THICK OVER COPPER STRIKE
 3. PHOSPHOR BRONZE PER QQ-B-750
 4. GOLD PL., 3 MIN. THICK OVER NICKEL PL., 100 MIN. THICK OVER COPPER STRIKE
 5. JIS H 3260, C 3501

1. CRIMPED FERRULE
HEX CRIMP SIZE .178"
2. CRIMPED CONTACT PIN
HEX CRIMP SIZE .068"

DIMENSIONS ARE IN MILLIMETERS					PART NO. B6121E1-ND3G-6-75		Amphenol			
UNLESS OTHERWISE SPECIFIED TOLERANCES					APPROVED	DATE			TITLE	
6	FERRULE	NOTE 5	NOTE 2	1	FR-52/44-38/3 X14		10-11-01'	BNC CRIMP JACK		
5	SLEEVE	DELTRIN	NATURAL	1	SL-25/17X115	CHECKED	10-11-01'			
4	CONTACT PIN	NOTE 3	NOTE 4	1	B74000-8-25/04	DRAWN	10-11-01'			
3	INSULATOR	DELTRIN	NATURAL	1	B74050-3-75-B			DRAWING NO. KJ-B6121E1-ND3G-179U-75		
2	BODY	NOTE 1	NOTE 2	1	B74000-2			ITEM NO.		
1	HOUSING	NOTE 1	NOTE 2	1	B70002-1-38/27					
NO.	DESCRIPTION	MATERIAL	FINISH	QTY	DRAWING NO.	SCALE	3/1	ISSUE	A	FILE NO.