



PART NO.

13-10-1 BT2003 75 OHM TGZ

REVISIONS

ECN #	REV	DESCRIPTION	DRAWN	DATE	CHECKD	DATE	APPRVD	DATE
-	A	RELEASED	Nirosha	31/8/07	Suresh	31/8/07	G. C	17/9/07

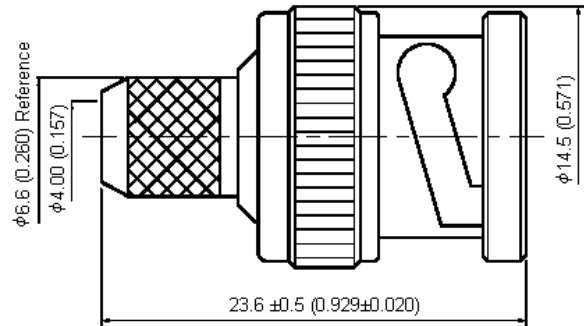
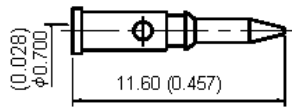
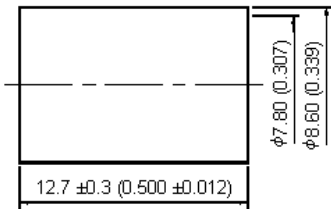

**Specifications:**

- Bodies : Brass per JIS-C3604.
- Centre Contact : Brass per JIS-C3604.
- Insulation : Teflon per ASTM D1457 and ASTM D1710.
- Crimp Ferrule : Brass per JIS-C2700.
- Part to be clean and free of burrs.

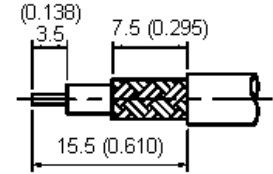

**Stripping Dimension**

Dimensions : Millimetres (Inches)

This data sheet and its contents (the "Information") belong to the Premier Farnell Group (the "Group") or are licensed to it. No licence is granted for the use of it other than for information purposes in connection with the products to which it relates. No licence of any intellectual property rights is granted. The Information is subject to change without notice and replaces all data sheets previously supplied. The Information supplied is believed to be accurate but the Group assumes no responsibility for its accuracy or completeness, any error in or omission from it or for any use made of it. Users of this data sheet should check for themselves the Information and the suitability of the products for their purpose and not make any assumptions based on information included or omitted. Liability for loss or damage resulting from any reliance on the Information or use of it (including liability resulting from negligence or where the Group was aware of the possibility of such loss or damage arising) is excluded. This will not operate to limit or restrict the Group's liability for death or personal injury resulting from its negligence. SPC MULTICOMP is the registered trademark of the Group. © Premier Farnell plc 2007.

**TOLERANCES:**  
UNLESS OTHERWISE SPECIFIED, DIMENSIONS ARE FOR REFERENCE PURPOSES ONLY.

<b>DRAWN BY:</b>	<b>DATE:</b>
Nirosha	31/08/07
<b>CHECKED BY:</b>	<b>DATE:</b>
Suresh	31/08/07
<b>APPROVED BY:</b>	<b>DATE:</b>
G.Cook	17/09/07

<b>DRAWING TITLE:</b>			
13-10-1 BT2003 75 OHM TGZ			
<b>SIZE</b>	<b>DWG NO.</b>	<b>ELECTRONIC FILE</b>	<b>REV</b>
A	M10000437	1169561_DWG	A
<b>SCALE:</b> NTS		<b>U.O.M.:</b> mm (Inches)	<b>SHEET:</b> 1 OF 2



PART NO.

13-10-1 BT2003 75 OHM TGZ

REVISIONS

ECN #	REV	DESCRIPTION	DRAWN	DATE	CHECKD	DATE	APPRVD	DATE
-	A	RELEASED	Nirosha	31/8/07	Suresh	31/8/07	G. C	17/9/07

Specification Table

Number	Description	Material	Finish	Part Number
1	Body	Brass	Nickel 100µ" Minimum	13-10-1 BT2003 75 OHM TGZ
2	Washer			
3	Spring Washer	SK-5		
4	Washer	Brass		
5	Gasket	Rubber	None	
6	Insulation	Teflon		
7	Shell	Zinc	Nickel 100µ" Minimum	
8	Crimp Ferrule	Brass	Gold	
9	Centre Contract			

<http://www.farnell.com>  
<http://www.newark.com>  
<http://www.cpc.co.uk>

This data sheet and its contents (the "Information") belong to the Premier Farnell Group (the "Group") or are licensed to it. No licence is granted for the use of it other than for information purposes in connection with the products to which it relates. No licence of any intellectual property rights is granted. The Information is subject to change without notice and replaces all data sheets previously supplied. The Information supplied is believed to be accurate but the Group assumes no responsibility for its accuracy or completeness, any error in or omission from it or for any use made of it. Users of this data sheet should check for themselves the Information and the suitability of the products for their purpose and not make any assumptions based on information included or omitted. Liability for loss or damage resulting from any reliance on the Information or use of it (including liability resulting from negligence or where the Group was aware of the possibility of such loss or damage arising) is excluded. This will not operate to limit or restrict the Group's liability for death or personal injury resulting from its negligence. SPC MULTICOMP is the registered trademark of the Group. © Premier Farnell plc 2007.

**TOLERANCES:**  
UNLESS OTHERWISE SPECIFIED, DIMENSIONS ARE FOR REFERENCE PURPOSES ONLY.

<b>DRAWN BY:</b>	<b>DATE:</b>
Nirosha	31/08/07
<b>CHECKED BY:</b>	<b>DATE:</b>
Suresh	31/08/07
<b>APPROVED BY:</b>	<b>DATE:</b>
G.Cook	17/09/07

<b>DRAWING TITLE:</b>			
13-10-1 BT2003 75 OHM TGZ			
<b>SIZE</b>	<b>DWG NO.</b>	<b>ELECTRONIC FILE</b>	<b>REV</b>
A	M10000437	1169561_DWG	A
<b>SCALE: NTS</b>		<b>U.O.M.: mm (Inches)</b>	<b>SHEET: 2 OF 2</b>