

GSD

1705-2

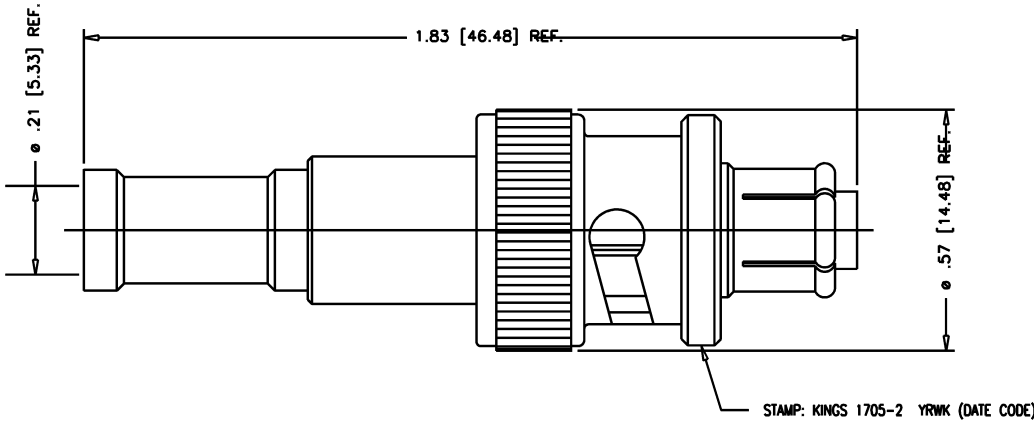

- NOTES:
1. FOR USE WITH RG-58, 58A, 58C, 141 & 141A/U CABLES.
 2. FOR CABLING INSTRUCTIONS SEE CP-441.
 3. FOR CRIMPING USE DIE KTH-2061.
 4. FOR CABLE TRIMMING USE KTJ-72 & KTD-136.
 5. INTERFACE PER MIL-STD-348, FIG. 314-2.
 6. MATERIALS:
 INSULATOR: TEFLON, ASTM-D4894
 GASKET: SIL. RUB., A-A-59588
 K-GRIP SLEEVE: COM. BRONZE TUBE, ASTM-B135
 SPRING WASHER & CONTACTS: BER. COP., ASTM-B196
 ALL OTHER PARTS: BRASS, ASTM-B16
 7. FINISHES:
 CENTER CONTACT: GOLD, ASTM-B488
 SPRING WASHER: SILVER, ASTM-B700
 ALL OTHER METAL PARTS: KINGS TARNISH RESISTANT NICKEL FINISH (TR-5)
 8. ELECTRICAL CHARACTERISTICS:
 OPERATING VOLTAGE: 3500 VOLTS AC
 5000 VOLTS DC

REVISIONS	
ISSUE	CHANGES
7	CN 39706 C REDRAWN DRK 11/17/06
SCALE 4:1	
APPROX SURFACE AREA	
USED ON	
REF:	
PLUG, SHV	
DRAWN DRK	DATE 11/17/06
DESIGN MJB	DATE 10/18/94
APPR.	DATE
 ROCK HILL, SOUTH CAROLINA 29730	
1705-2	

GSD