

DASH NO.	M CODE	MADE FROM
----------	--------	-----------

GSD

1705-1

REVISIONS	
ISSUE	CHANGES
6	CN 32731 C REDRAWN KH 12/10/90
7	CN 35381 E MJB 03/30/94
8	CN 37799 E TML 03/09/99
9	CN 39699 C DCT 11/14/6

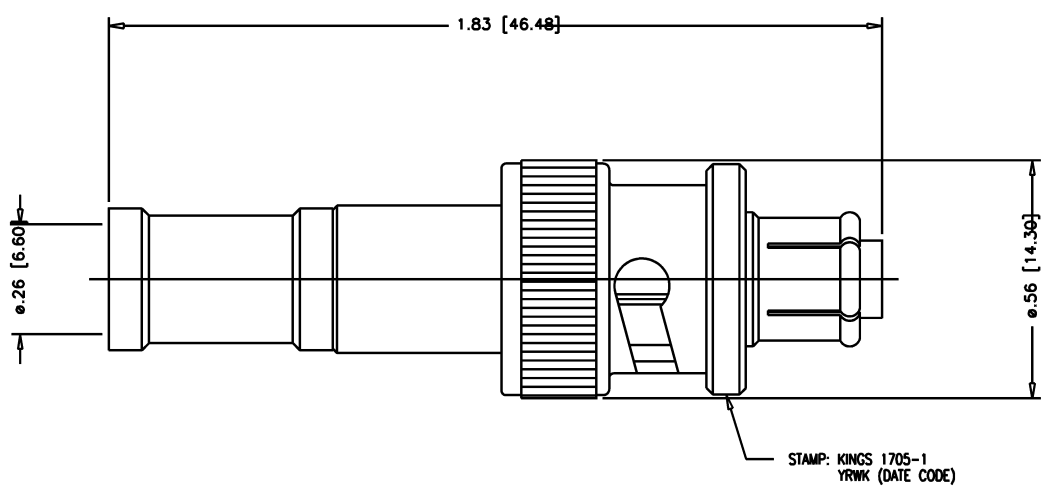

- NOTES:
- FOR USE WITH RG-59, 62 & 210/U CABLE.
 - FOR CABLING INSTRUCTIONS SEE CP-441.
 - FOR CABLE TRIMMING USE KTJ-72 & KTD-134.
 - FOR CRIMPING USE DIE KTH-2062.
 - MATERIALS:
INSULATOR: TEFLON, ASTM-D-4894
GASKET: SIL. RUB., A-A-59588
K-GRIP SLEEVE: COMMERCIAL BRONZE TUBE, ASTM-B135
SPRING WASHER & CONTACTS: BER. COP., ASTM-B-196
ALL OTHER PARTS: BRASS, ASTM-B16
 - FINISHES:
CENTER CONTACT: HARD GOLD PLT. PER ASTM-B488
ALL OTHER METAL PARTS: KINGS TARNISH RESISTANT FINISH (TR-5)
 - ELECTRICAL CHARACTERISTICS:
OPERATING VOLTAGE: 3500 VOLTS AC
5000 VOLTS DC
 - DIMENSIONS IN INCHES [MM].

SCALE 4:1
APPROX SURFACE AREA
USED ON
REF: N.B.S. ND-545C
PLUG, SHV
DRAWN JCA DATE 12/10/90
DESIGN LI DATE 12/11/90
APPR. DATE

KINGS
ELECTRONICS CO., INC.
ROCK HILL, SOUTH CAROLINA 29730

1705-1

GSD