

PART NUMBER	ITEM ①	ITEM ②	ITEM ③	ITEM ④	PACKAGING
	BODY	CONTACT	INSULATOR	INSULATOR	
142-D711-301	BRASS GOLD PL .00001 MIN OVER NICKEL PL .00005 MIN OVER COPPER PL .00005 MIN	BERYLLIUM COPPER GOLD PL .00003 MIN OVER NICKEL PL .00005 MIN OVER COPPER PL .00005 MIN	TEFLON	TEFLON	BULK PACK 25 PCS.
142-D711-302	BRASS GOLD PL .00001 MIN OVER NICKEL PL .00005 MIN OVER COPPER PL .00005 MIN	BERYLLIUM COPPER GOLD PL .00003 MIN OVER NICKEL PL .00005 MIN OVER COPPER PL .00005 MIN	TEFLON	TEFLON	TAPE AND REEL 425 PCS. PER FIG 1
142-D711-305	BRASS NICKEL PL .00011 MIN OVER COPPER PL .00005 MIN	BERYLLIUM COPPER GOLD PL .00003 MIN OVER NICKEL PL .00005 MIN OVER COPPER PL .00005 MIN	TEFLON	TEFLON	BULK PACK 25 PCS.
142-D711-306	BRASS NICKEL PL .00011 MIN OVER COPPER PL .00005 MIN	BERYLLIUM COPPER GOLD PL .00003 MIN OVER NICKEL PL .00005 MIN OVER COPPER PL .00005 MIN	TEFLON	TEFLON	TAPE AND REEL 425 PCS. PER FIG 1

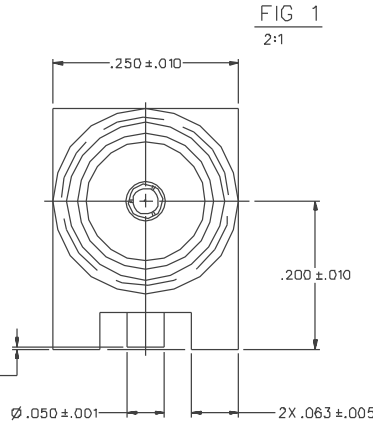
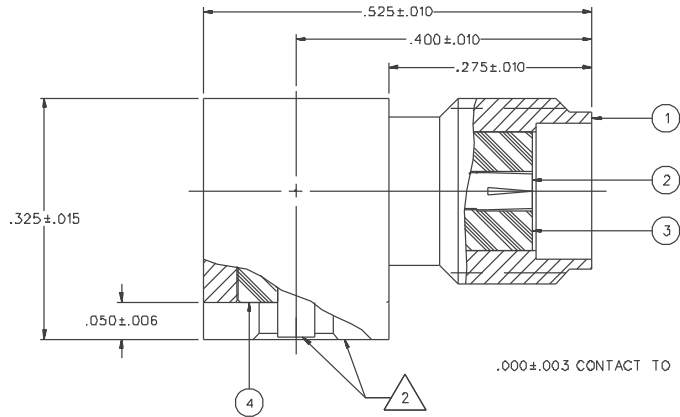
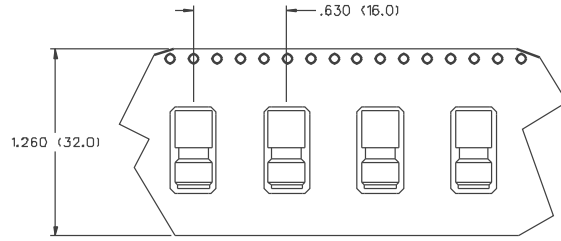

NOTES:

1. SPECIFICATIONS:

IMPEDANCE: 50 OHMS
 FREQUENCY RANGE: 0-18 GHZ
 VSWR: NOT APPLICABLE
 WORKING VOLTAGE: 335 VRMS MAX AT SEA LEVEL
 DIELECTRIC WITHSTANDING VOLTAGE: 1000 VRMS MIN AT SEA LEVEL
 INSULATION RESISTANCE: 5000 MEGOHM MIN
 CONTACT RESISTANCE:
 CENTER CONTACT - INITIAL 3 MILLIOHM MAX, AFTER ENVIRONMENTAL 4 MILLIOHM MAX
 OUTER CONDUCTOR - INITIAL 2 MILLIOHM MAX, AFTER ENVIRONMENTAL NOT APPLICABLE
 BRAID TO BODY - NOT APPLICABLE
 CORONA LEVEL: 250 VOLTS MIN AT 70,000 FEET
 INSERTION LOSS: NOT APPLICABLE
 RF LEAKAGE: NOT APPLICABLE
 RF HIGH POTENTIAL WITHSTANDING VOLTAGE: 670 VRMS AT 4 AND 7 MHZ

MECHANICAL:
 ENGAGE/DISENGAGE TORQUE: 2 INCH-POUNDS MAX
 MATING TORQUE: 7-10 INCH POUNDS MAX
 COUPLING PROOF TORQUE: 10 INCH POUNDS MAX
 COUPLING NUT RETENTION: NOT APPLICABLE
 CONTACT RETENTION: 6 LBS MIN AXIAL FORCE
 CABLE ACCEPTABILITY: NOT APPLICABLE
 CABLE HEX CRIMP SIZE: NOT APPLICABLE
 CABLE RETENTION: NOT APPLICABLE
 DURABILITY: 500 CYCLES MIN

ENVIRONMENTAL:
 (MEETS OR EXCEEDS THE APPLICABLE PARAGRAPH OF MIL-C-39012)
 THERMAL SHOCK: MIL-STD-202, METHOD 107, CONDITION B
 OPERATING TEMPERATURE: -65 DEG C TO 165 DEG C
 CORROSION: MIL-STD-202, METHOD 101, CONDITION B
 SHOCK: MIL-STD-202, METHOD 213, CONDITION I
 VIBRATION: MIL-STD-202, METHOD 204, CONDITION D

RECOMMENDED LAND PATTERN

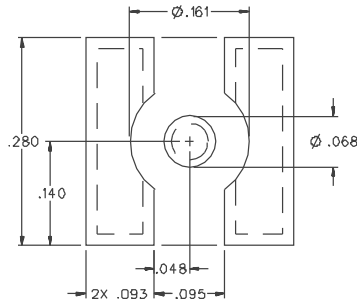

NOTE:
 APPLY A MAXIMUM OF 10 POUND INCH TORQUE TO MATING CONNECTOR COUPLING NUT OR FIXTURE BODY OF THIS CONNECTOR WITH A WRENCH WHILE TIGHTENING.

* NOTE: THIS PATTERN IS FOR REFERENCE ONLY. PATTERN MAY VARY DEPENDING ON ASSEMBLY PROCESS OR SPECIFIC ELECTRICAL OR MECHANICAL REQUIREMENTS.

DRAWING NO. C - 142-0711-301/310			
0 REVISIONS			
ENGINEERING RELEASE			
1	7-20-93	R T B	7-30-93
DELETED: MOISTURE SEAL SPEC			
* REVISION NUMBER FOLLOWED BY AN ALPHA *			
* CHARACTER INDICATES DRAWING CLASS *			
* CATION OR PART NUMBER ADDITION ONLY *			
1a	7-20-93	R T B	ECN 45,356
ADDED P/N'S - 302, -306, ADDED TAPE AND REEL PACKAGING .0001-.003 WAS .003+-006			
2	5-1-01	R T B	ECO 47906

CUSTOMER DRAWING
 THIS DRAWING TO BE INTERPRETED PER ANS Y 14.5M - 1982
 "µSTATION"
 COMPANY CONFIDENTIAL

TOLERANCE UNLESS OTHERWISE SPECIFIED	DRAWN BY VET	DATE 3-1-93	 299 Johnson Ave. P.O. Box 1732 Waseca, MN 56093-0832
DECIMALS .XX	CHECKED BY	DATE	
.XXX--003	APPROVED BY TAK	DATE 7-22-93	TITLE JACK ASSEMBLY RA SURFACE MOUNT SMA
MATL	APPROVED BY RJS	DATE 7-23-93	CODE NO. C - 142-0711-301/310
FINISH	RELEASE DATE	7-30-93	SCALE 10:1 (U/M INCH(MM)) SHEET 2 OF 2

CONNECTOR MOUNTING RAILS 60%/40% TIN/LEAD COATED (SOLDER PLATED)