

ALL RIGHTS RESERVED. NO PORTION OF THIS PUBLICATION, WHETHER IN WHOLE OR IN PART CAN BE REPRODUCED WITHOUT THE EXPRESS WRITTEN CONSENT OF SPC TECHNOLOGY.

SPC-F008.DWG

REVISONS		DOC. NO. SPC-F008	Effective 7/8/02	DCP No 1308				
DCP #	REV	DESCRIPTION	DRAWN	DATE	CHECKD	DATE	APPRVD	DATE
1957	A	RELEASED	JJM	09/09/08	JJM	09/09/08	JJM	09/09/08

## Specifications

### Environmental

- Temperature Range: -65°C to +125°C

### Mechanical

- Insulator Material: Glass filled polyester, black, UL94V-0
- Contact Material: Phosphor Bronze
- Contact Plating: .000250 [.00635] 90/10 Tin/Lead Alloy over .000075 [.00190] nickel
- Contact Insertion Force: 6.2 oz [1.7 N] Typ  
10.6 oz [2.9 N] MAX
- Contact Extraction Force: 1.8 oz [0.5N] Typ  
0.7 oz [0.2N] Min  
Measured with .0145 [0.375] dia pin
- Recommended Mating Pin Size: .022 [0.56] (W) x .020 [0.51] (T)Max  
.010 [0.25] x .008 [0.20]Min

### Electrical

- Current Rating: 1 Amp
- Voltage Rating: 300 Vrms
- Dielectric Withstanding Voltage: 500 Vrms Min
- Insulation Resistance: >5000 Megohms
- Contact Resistance: 10 Milliohms Typ  
30 Milliohms Max

SPC Type #	No. Of Positions	Dimension "A"		Dimension "B"		Dimension "C"		Dimension "D"	
		IN	MM	IN	MM	IN	MM	IN	MM
SPC22187	14	0.745	18.92	0.6	15.24	0.3	7.62	0.395	10.03
SPC22191	16	0.845	21.46	0.7	17.78	0.3	7.62	0.395	10.03
SPC22194	24	1.245	31.62	1.1	27.94	0.6	15.24	0.695	17.65
SPC22197	40	2.045	51.94	1.9	48.26	0.6	15.24	0.695	17.65

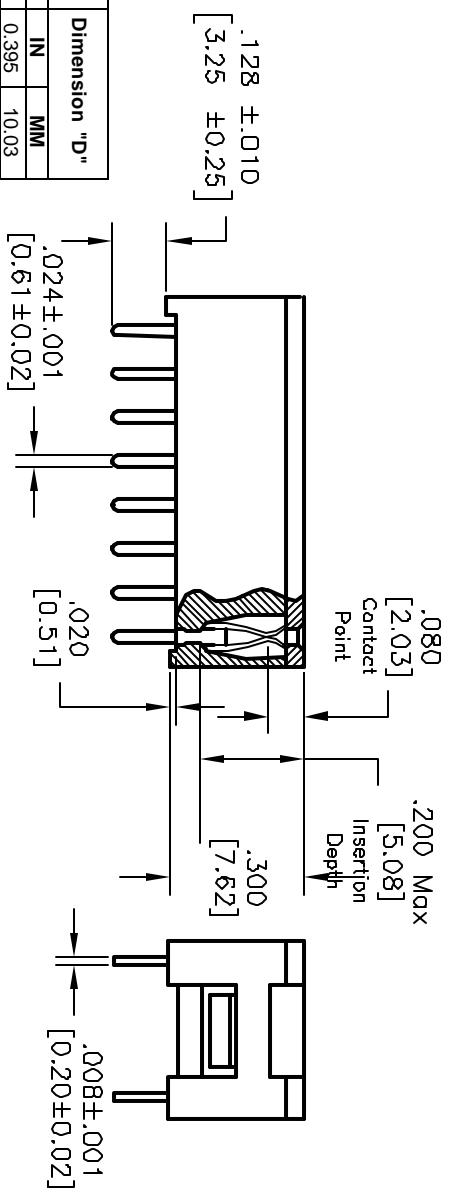
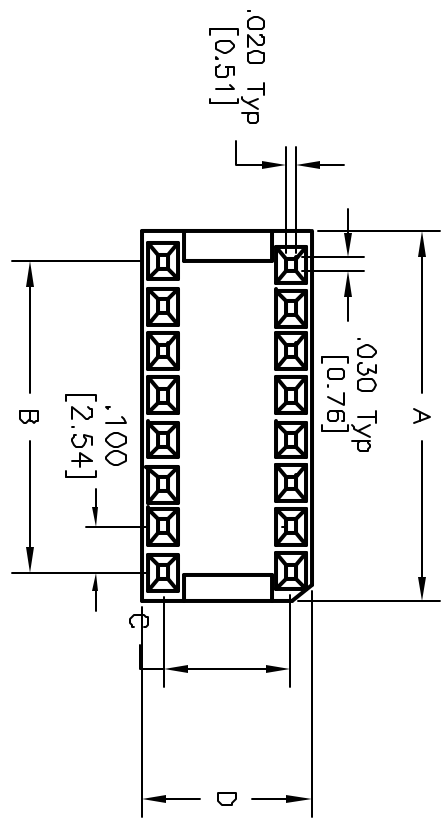

**DISCLAIMER:**  
ALL STATEMENTS AND TECHNICAL INFORMATION CONTAINED HEREIN ARE BASED UPON INFORMATION AND/OR TESTS WE BELIEVE TO BE ACCURATE AND RELIABLE. SINCE CONDITIONS OF USE ARE BEYOND OUR CONTROL, THE USER SHALL DETERMINE THE SUITABILITY OF THE PRODUCT FOR THE INTENDED USE AND ASSUME ALL RISK AND LIABILITY WHATSOEVER IN CONNECTION THEREWITH.

**TOLERANCES:**  
Tolerances: Unless Otherwise Specified:  
XX = ±0.10 [X=±.25mm]  
.XXX = ±0.05 [XX=±.13mm]  
Angles = ±3°

<b>DRAWN BY:</b>	Jason Nash	<b>DATE:</b>	09/09/08
<b>CHECKED BY:</b>	JJM	<b>DATE:</b>	09/09/08
<b>APPROVED BY:</b>	JJM	<b>DATE:</b>	09/09/08

<b>DRAWING TITLE:</b>		<b>SCALE:</b>		<b>SHEET:</b>	
Socket Standard .300 High Solder DIP Tail		NTS		1 OF 1	
<b>SIZE</b>	<b>DWG. NO.</b>	<b>ELECTRONIC FILE</b>	<b>REV</b>		
A	Ta-936	Ta-936.dwg	A		