

Customer Information Sheet

DRAWING No.: M80-101XX98S

IF IN DOUBT - ASK

©

NOT TO SCALE

THIRD ANGLE PROJECTION

ALL DIMENSIONS IN mm

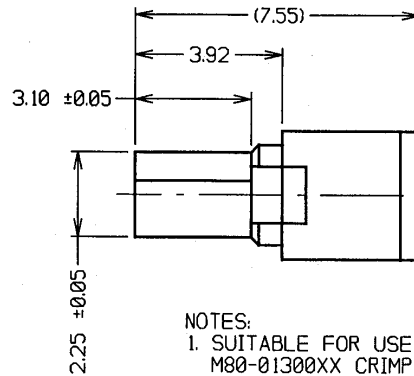
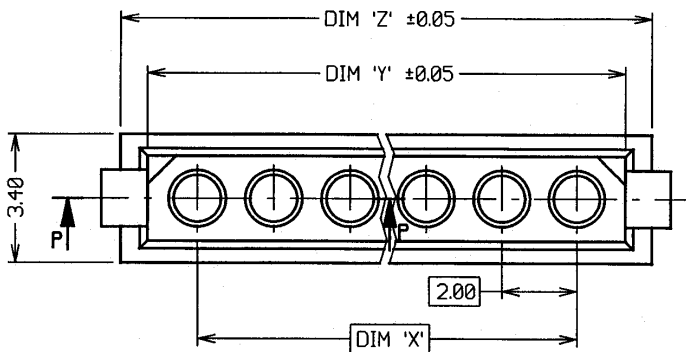

ORDER CODE:
M80-101XX98S
No. OF WAYS:
02-07, 17

NOTES:
1. SUITABLE FOR USE WITH M80-01100XX AND M80-01300XX CRIMP SOCKETS.

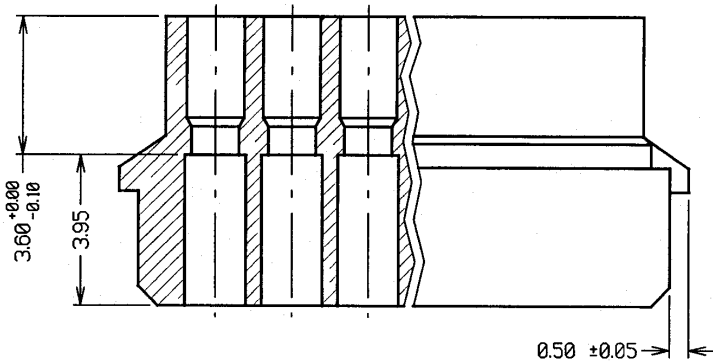

PART SECTION P-P

SPECIFICATIONS:
MATERIAL = GLASS-FILLED POLYESTER UL94V-0 (BLACK)
ALL OTHER APPLICABLE SPECIFICATIONS ARE SHOWN IN COMPONENT SPECIFICATION C001XX (LATEST ISSUE), AND APPLY WHEN CRIMP SOCKETS ARE ASSEMBLED.

PART No.	DIM 'X'	DIM 'Y'	DIM 'Z'
M80-1010298S	2.00	4.60	6.00
M80-1010398S	4.00	6.60	8.00
M80-1010498S	6.00	8.60	10.00
M80-1010598S	8.00	10.60	12.00
M80-1010698S	10.00	12.60	14.00
M80-1010798S	12.00	14.60	16.00
M80-1011798S	32.00	34.60	36.00

1	25.02.99	----
ISS.	DATE	REV
APPROVED:	<i>[Signature]</i>	
CHECKED:	<i>[Signature]</i>	
DRAWN:	W. J. BOURNE	
CUSTOMER REF.		
ASSEMBLY DRG:		

HARWIN

HARWIN INC
U.S.A.
TEL: (812) 285 0055
FAX: (812) 285 0056

HARWIN PLC
UK.
TEL: 01705 370451
FAX: 01705 314590

HARWIN PTE
SINGAPORE
TEL: 65 7794909
FAX: 65 7793868

TOLERANCES
X - ±1mm
X.X - ±0.25mm
X.XX - ±0.10mm
X.XXX - ±0.01mm
ANGLES - ±1°
UNLESS STATED

MATERIAL:
M80-101XX98

FINISH:
S/AREA: mm'

TITLE:
DATAMATE SIL CRIMP MOULDING

DRAWING NUMBER:
M80-101XX98S

SHT
1 OF 1