

DO NOT SCALE
DIMENSIONS IN mm

METRIC

THIRD ANGLE
PROJECTION

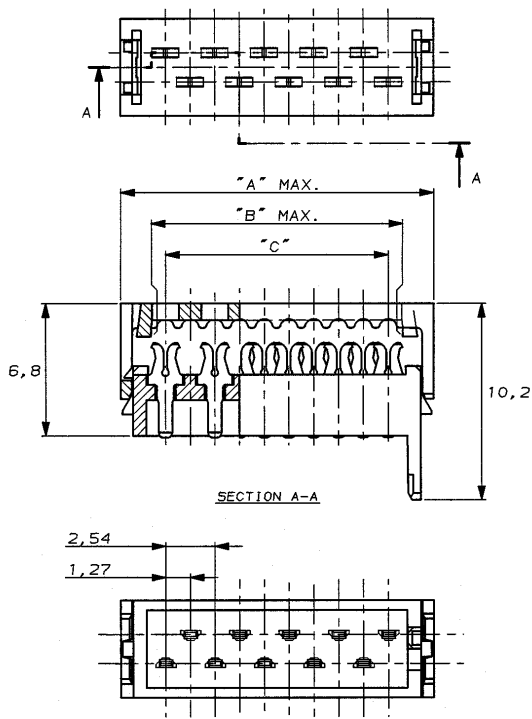

NUMBER OF POSITIONS	PARTNUMBER BOXPACKAGING	PARTNUMBER REELPACKAGING	NUMBER OF POSITIONS	DIMENSION		
				"A" MAX.	"B" MAX.	"C"
4	7-215083-4	0-215083-4	4	8,6	5,4	3,81
6	7-215083-6	0-215083-6	6	11,1	8,0	6,35
8	7-215083-8	0-215083-8	8	13,6	10,5	8,89
10	8-215083-0	1-215083-0	10	16,2	13,0	11,43
12	8-215083-2	1-215083-2	12	18,7	15,6	13,97
14	8-215083-4	1-215083-4	14	21,3	18,1	16,51
16	8-215083-6	1-215083-6	16	23,8	20,7	19,05
18	8-215083-8	1-215083-8	18	26,3	23,2	21,59
20	9-215083-0	2-215083-0	20	28,9	25,7	24,13

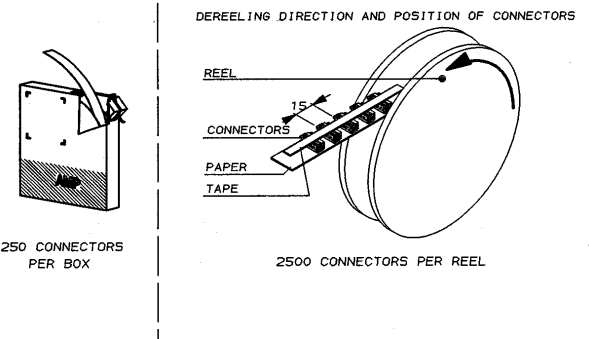

DESCRIPTION	MATERIAL	ITEM
MALE HOUSING	GLASS FILLED POLYESTER (RED)	3
MALE CONTACT	PHBR. PLATING TIN-LEAD 93-7	2
COVER	GLASS FILLED POLYESTER (RED)	1

NOTE
1. 10 POSITIONS AS SHOWN

REVISION RECORD				CUSTOMER DRAWING		FOR REFERENCE ONLY WILL NOT BE UPDATED	
DR.	P.v.Tongeren	CHK.	H.Kokken	APP.		© COPYRIGHT 19- BY AMP HOLLAND B.V.	
DATE:	-	DATE:	-	DATE:	-	ALL INTERNATIONAL RIGHTS RESERVED. AMP PRODUCTS MAY BE COVERED BY U.S. AND FOREIGN AND/OR PATENTS PENDING.	
LTR. REVISION RECORD				NAME		THIS DRAWING IS UNPUBLISHED RELEASED FOR PUBLICATION	
P EH-1428-95				AMP		AMP HOLLAND B.V. 's-Hertogenbosch, The Netherlands.	
N -				MicroMaTch MALE ASS'Y		PITCH 1,27 mm	
LTR. REVISION RECORD				DWS. No.		REV. LTR. SHEET	
DATE: -				C-215083		P 1 OF 1	

DO NOT SCALE
DIMENSIONS IN mm

METRIC

THIRD ANGLE
PROJECTION

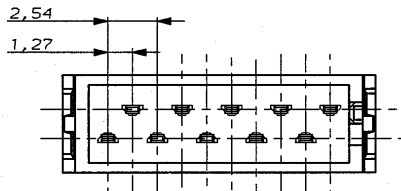
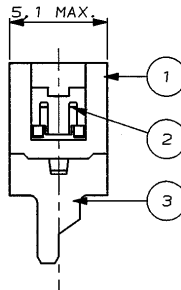
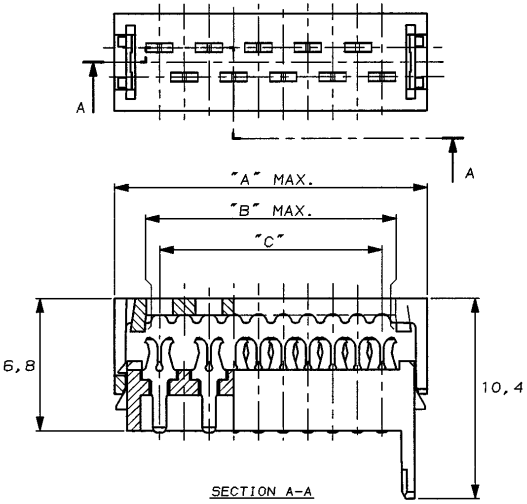

NOTE
1. 10 POSITIONS AS SHOWN

SUPERSEDED BY C-215083 SHEET 1

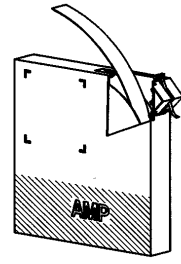

250 CONNECTORS PER BOX FOR ALL PARTNUMBERS.
FOR 2500 CONNECTORS PER REEL SEE SHEET 1.

NUMBER OF POSITIONS	PARTNUMBER MALE ASSIE
4	7-215083-4
6	7-215083-6
8	7-215083-8
10	8-215083-0
12	8-215083-2
14	8-215083-4
16	8-215083-6
18	8-215083-8
20	9-215083-0

MALE HOUSING	GLASS FILLED POLYESTER (RED)	3
MALE CONTACT	PHBR. PLATING TIN-LEAD 93-7	2
COVER	GLASS FILLED POLYESTER (RED)	1
DESCRIPTION	MATERIAL	ITEM

CUSTOMER DRAWING		AMP		AMP-HOLLAND B.V. s-Hertogenbosch, The Netherlands.	
FOR REFERENCE ONLY WILL NOT BE UPDATED		THIS DRAWING IS UNPUBLISHED. RELEASED FOR PUBLICATION			
DR. D.KESSLER		DATE 20-02-90		WIRE RANGE -	
CHK. J.SMIT		DATE -		INSUL. RANGE -	
APP. L.v.SOEST		DATE -		NAME Micro-Match MALE ASSY PITCH 1,27MM	
SIZE A3		SHEET 2 OF 2		DWG. No. C-215083	
REV. DATE D M Y		REV. LTR. P		28 02 90	

8 | 7 | 6 | 5 | 4 | 3 | 2 | 1