



This is our exclusive property. It is not to be copied, reprinted, or disclosed to a third party, nor used for manufacturing, without our written consent, and has to be returned to us.

		TE- 2204	Date Issued: June 2, 1987
Type of Document: TEST REPORT		Revised: D ECN NO. 0364	Date Revised: September 2, 1994
Title Subject: VH CONNECTOR (PHOSPHOR BRONZE)			Issued by: Engineering Dept.

This report contains the results of general performance tests for VH connector(Phosphor Bronze).

-Index-

1. PART NAME & PART NUMBER
2. CONSTRUCTION, DIMENSIONS, MATERIAL & SURFACE FINISH
3. CHARACTERISTICS
4. SPECIMEN
5. TEST CONDITIONS
6. REQUIREMENTS, TEST METHODS & TEST RESULTS
  - 6.1 Appearance
  - 6.2 Mechanical Test
    - 6.2.1 Insertion Force & Withdrawal Force
    - 6.2.2 Crimp Tensile Strength
    - 6.2.3 Contact Insertion Force
    - 6.2.4 Contact Retention Force
    - 6.2.5 Post Retention Force
    - 6.2.6 Housing Lock Strength
  - 6.3 Electrical Test
    - 6.3.1 Contact Resistance
    - 6.3.2 Current Continuity
    - 6.3.3 Insulation Resistance
    - 6.3.4 Dielectric Withstanding Voltage
  - 6.4 Environmental Test
    - 6.4.1 Durability
    - 6.4.2 Vibration
    - 6.4.3 Humidity
    - 6.4.4 Heat Aging
    - 6.4.5 Thermal Shock
    - 6.4.6 Salt Spray
    - 6.4.7 Hydrogen Sulfide Gas
    - 6.4.8 Ammonia Gas
    - 6.4.9 Solderability
    - 6.4.10 Resistance to Soldering Heat

UNCONTROLLED ISSUE

THIS DRAWING / DOCUMENT IS THE PROPERTY OF J.S.T. (U.K.) LTD. IT MUST NOT BE REPRODUCED OR USED FOR MANUFACTURE WITHOUT WRITTEN PERMISSION FROM J.S.T. (U.K.) LTD.

Prepared by: <i>S. Muroya</i>	Checked by: <i>T. Yasuda</i>	Reviewed by: <i>K. Namaka</i>	Approved by: <i>P. Strijja</i>
----------------------------------	---------------------------------	----------------------------------	-----------------------------------



# J.S.T.

TEST REPORT  
VH CONNECTOR  
(PHOSPHOR BRONZE)

TE-2204

Revised: D

ECN No. 0364

This is our exclusive property.  
 It is not to be copied, reprinted, or disclosed to a third party, nor used for manufacturing, without our written consent, and has to be returned to us.

## 1. PART NAME & PART NUMBER

Part Name		Part Number
Contact		SVH-21T-PI.1
Housing		VHR-*N
		VHR-*M
Header	Top entry type	B*P-VH
	Side entry type	B*PS-VH
		S*P-VH

Note: \* represents one or two figures indicating number of circuits.  
Ex. 6-circuit housing --- VHR-6N

## 2. CONSTRUCTION, DIMENSIONS, MATERIAL & SURFACE FINISH

Construction and dimensions shall be in accordance with the referenced drawings. Material and surface finish shall be as specified below.

		Material	Surface Finish, etc.
Contact		Phosphor Bronze	Tin-plated
Housing		6 Nylon	UL 94V-0
Header	Post	Brass	Copper-underplated
			Tin/Lead alloy-plated
	Wafer	66 Nylon	UL 94V-0

## 3. CHARACTERISTICS

Current rating: 7 A AC, DC (When AWG #18 is applied)

Voltage rating: 250 V AC, DC

Temperature range: -25 °C to +85 °C (Including temperature rise.)

Applicable wire:

Conductor construction size: AWG #22, #20, #18

Wire insulation O.D.: 1.7 mm to 3.0 mm

Applicable printed circuit board (PCB): Thickness: 1.6 mm

Hole size: 1.65 +0.1/0 mm \*1

Notes: \*1 Recommended value in applying paper base, epoxy resin for PCB material and drill hole. Tolerance depends on PCB material and the work method.

2 Wire conductor shall be tin-plated soft copper wire (stranded wire).



# J.S.T.

TEST REPORT  
VH CONNECTOR  
(PHOSPHOR BRONZE)

TE-2204

Revised: D

ECN No. 0364

This is our exclusive property. It is not to be copied, reprinted, or disclosed to a third party, nor used for manufacturing, without our written consent, and has to be returned to us.

#### 4. SPECIMEN

Part Name	Part Number
Contact	SVH-21T-P1.1
Housing	VHR-*N
Header Top entry type	B*P-VH

Note: \* denotes number of circuits.

#### 5. TEST CONDITIONS

5.1 Unless otherwise specified, tests and measurements shall be conducted under the following ambient conditions.

Temperature: 15 to 35 °C  
Relative humidity: 25 to 85 %

5.2 For environmental test, connector assembled for actual use shall be used. Wire of AWG #20 UL1007 style shall be used.

#### 6. REQUIREMENTS, TEST METHODS & TEST RESULTS

##### 6.1 Appearance

Requirements: There shall be no crack, no deformation nor discoloration which may affect the performance.

Test method: Inspected with naked eyes before and after the environmental tests.

Test results: Good.

##### 6.2 Mechanical Test

##### 6.2.1 Insertion Force(I.F.) & Withdrawal Force(W.F.)

Requirements:

Number of circuits	At initial		(N) At 50th
	I.F. [max.]	W.F. [min.]	W.F. [min.]
Single	9.8	1.96	0.98
2	19.6	3.92	1.96
3	29.4	5.88	2.94
4	39.2	7.84	3.92
5	44.1	9.80	4.90
6	53.9	12.7	6.86
7	58.8	15.7	8.82
8	68.6	18.6	10.8
9	73.5	21.6	12.7
10	78.4	24.5	14.7



# J.S.T.

TEST REPORT  
VH CONNECTOR  
(PHOSPHOR BRONZE)

TE-2204

Revised: D

ECN No. 0364

This is our exclusive property. It is not to be copied, reprinted, or disclosed to a third party, nor used for manufacturing, without our written consent, and has to be returned to us.

Test method: A housing with contact(s) and a header shall be mated and unmated on a same axis. Initial insertion and withdrawal forces and withdrawal force at 50th shall be measured. Housing lock shall be removed.

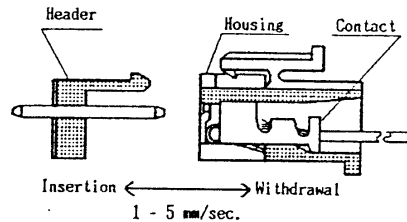

Test results:

No. of circuits		At Initial		(N) At 50th
		I.F.	W.F.	W.F.
Single	Max.	4.90	4.90	4.90
	Min.	3.92	2.94	1.96
	Ave.	4.31	3.82	3.33
2	Max.	10.8	10.8	7.68
	Min.	7.84	6.86	4.90
	Ave.	9.41	8.33	6.76
3	Max.	14.7	13.7	13.7
	Min.	12.7	10.8	8.82
	Ave.	13.8	11.9	10.5
4	Max.	19.6	19.6	15.7
	Min.	13.7	13.7	10.8
	Ave.	18.2	16.3	13.1
5	Max.	27.4	23.5	25.5
	Min.	23.5	19.6	16.7
	Ave.	25.2	21.7	20.2
6	Max.	31.4	32.3	24.5
	Min.	28.4	24.5	15.7
	Ave.	29.2	28.3	20.0
7	Max.	41.2	33.3	25.5
	Min.	30.4	28.4	29.6
	Ave.	25.6	30.5	22.5
8	Max.	41.2	41.2	31.4
	Min.	37.2	34.3	21.6
	Ave.	39.9	37.2	27.0
9	Max.	50.0	43.1	38.2
	Min.	43.1	36.3	27.4
	Ave.	46.9	40.9	33.5
10	Max.	54.9	51.9	34.3
	Min.	48.0	37.2	23.5
	Ave.	51.1	43.4	28.5

N=20



TEST REPORT VH CONNECTOR (PHOSPHOR BRONZE)	TE-2204
Revised: D	ECN No. 0364

This is our exclusive property. It is not to be copied, reprinted, or disclosed to a third party without the written consent of J.S.T. and has to be returned to us.

### 6.2.2 Crimp Tensile Strength

Requirements:

AWG #22 (0.33mm <sup>2</sup> )	44.1 N min.
AWG #20 (0.52mm <sup>2</sup> )	63.7 N min.
AWG #18 (0.82mm <sup>2</sup> )	78.4 N min.

Test method: Pulling load shall be applied between a correctly crimped contact and wire at the constant speed of 25 mm per minute. The load to pull the wire out of the contact or break the wire shall be measured.

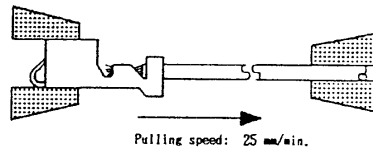

Test results:

Wire size	Max.	Min.	Ave.	(N)
AWG #22	98.0	82.3	90.5	
AWG #20	143	136	139	
AWG #18	200	188	194	
				N=20

### 6.2.3 Contact Insertion Force

Requirements: 14.7 N max.

Test method: The force required to insert a crimped contact into a housing shall be measured. Inserting speed shall be 1 to 5 mm per second.

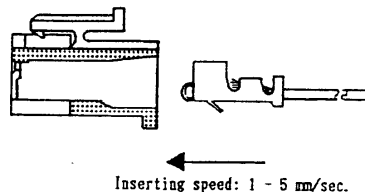

Test results:

Max.	Min.	Ave.	(N)
6.86	4.90	5.98	
			N=20



# J.S.T.

TEST REPORT  
VH CONNECTOR  
(PHOSPHOR BRONZE)

TE-2204

Revised: D

ECN No. 0364

This is our exclusive property.  
 It is not to be copied, reprinted, or disclosed to a third  
 party, nor used for manufacturing, without our written  
 consent, and has to be returned to us.

## 6.2.4 Contact Retention Force

Requirements: 29.4 N min.

Test method: A crimped contact mounted in a housing shall be pulled in an alignment at a constant speed of 1 to 5 mm per second. The load to pull the contact out of the housing shall be measured.

Test results:

(N)			N=20
Max.	Min.	Ave.	
94.1	54.9	71.1	

## 6.2.5 Post Retention Force

Requirements: 29.4 N min.

Test method: The end of a post shall be pushed in a perpendicular to wafer at the constant speed of 1 to 5 mm per second. The load to make the post start moving shall be measured.

Test results:

(N)			N=20
Max.	Min.	Ave.	
80.4	51.9	67.5	

## 6.2.6 Housing Lock Strength

Requirements: 2-circuit: 14.7 N min.  
3 to 10-circuit: 49.0 N min.

Test method: Pulling load shall be applied to a housing in the direction that the housing separates from a header at the constant speed of 1 to 5 mm per second. The load required to separate shall be measured.

Test results:

No. of circuits	(N)			N=20
	Max.	Min.	Ave.	
2	26.5	24.5	25.3	
3 to 10	100	87.2	93.8	



# J.S.T.

TEST REPORT  
VH CONNECTOR  
(PHOSPHOR BRONZE)

TE-2204

Revised: D

ECN No. 0364

This is our exclusive property.  
 It is not to be copied, reprinted, or disclosed to a third  
 party without the written consent of J.S.T. and has to be returned to us.

## 6.3 Electrical Test

### 6.3.1 Contact Resistance

Requirements: Initial: 10 mΩ max.  
After environmental tests: 20 mΩ max.

Test method: Electrical resistance between points a and b shown in the figure below shall be measured under the following conditions.

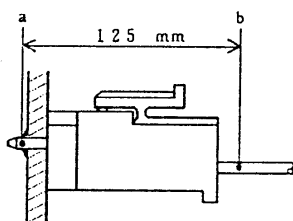

Test current: 10 mA (DC)  
Open voltage: 20 mV max.  
Wire: AWG #20

Test results: See items 6.4.1 - 6.4.7.

### 6.3.2 Current Continuity

Requirements: There shall be no current discontinuity longer than 1 microsecond during a vibration test.

Test method: Each circuit of a connector shall be connected in series. Current discontinuity longer than 1 microsecond during a vibration test shall be detected by continuity meter.

Test results: See item 6.4.2.

### 6.3.3 Insulation Resistance

Requirements: Initial: 1000 MΩ min.  
After humidity test: 500 MΩ min.  
After thermal shock test: 500 MΩ min.

Test method: 500 V DC shall be applied between the outer surface of a housing and a contact and also between adjacent contacts to measure insulation resistance.

Test results: See items 6.4.3 and 6.4.5.



# J.S.T.

TEST REPORT  
VH CONNECTOR  
(PHOSPHOR BRONZE)

TE-2204

Revised: D

ECN No. 0364

This is our exclusive property. This report is to be copied, reprinted, or disclosed to a third party without our written consent, and has to be returned to us.

### 6.3.4 Dielectric Withstanding Voltage

Requirements: There shall be no breakdown nor flashover.

Test method: Initially 1500 V AC (rms) and after a humidity and a thermal shock tests 1000 V AC(rms) shall be applied between the outer surface of housing and a contact and also between adjacent contacts for one minute.

Test results: See items 6.4.3 and 6.4.5.

### 6.4 Environmental Test

#### 6.4.1 Durability

Requirements: Contact resistance shall be 20 milliohms max. after the test.

Test method: A housing with contacts and a header shall be mated and unmated. After repeated 50 cycles, contact resistance shall be measured.

Test results:

Test item	Initial			After test		
	Max.	Min.	Ave.	Max.	Min.	Ave.
Contact resistance	5.4	5.2	5.28	6.0	5.3	5.50

(mΩ)  
N=20

\* Data show the values after 100 cycles.

#### 6.4.2 Vibration

Requirements: Contact resistance shall be 20 milliohms max. after the test. There shall be no current discontinuity longer than 1 microsecond during the test.

Test method: A mated connector shall be mounted on a PCB and subjected to a vibration test of the following conditions. During the test, current continuity shall be checked. After the test, contact resistance shall be measured.

Frequency: 10-55-10 Hz/min.  
Amplitude: 1.52 mm  
Direction: 1. Axis of up and down  
              2. Axis of right and left  
              3. Axis of front and back  
Period: 2 hours for each direction





TEST REPORT  
VH CONNECTOR  
(PHOSPHOR BRONZE)

TE-2204

Revised: D

ECN No. 0364

This is our exclusive property. It is not to be copied, reproduced, or disclosed to a third party, nor used for manufacturing without our written consent, and has to be returned to us.

Test results:

Test item	Initial			After test		
	Max.	Min.	Ave.	Max.	Min.	Ave.
Contact resistance	5.4	5.1	5.27	5.6	5.4	5.50

N=20

Current continuity:

There was no current discontinuity during the test.

## 6.4.3 Humidity (Steady State)

Requirements: Contact resistance shall be 20 milliohms max. after the test. Insulation resistance shall be 500 megohms min. after the test. There shall be no breakdown nor flashover on the dielectric withstanding voltage test.

Test method: A mated connector shall be placed in a humidity chamber of the following conditions. After the test, contact resistance, insulation resistance and dielectric withstanding voltage shall be measured.

Temperature:  $40 \pm 2$  °C  
Relative humidity: 90 to 95 %  
Period: 240 hours continuously

Test results:

Test item	Initial			After test		
	Max.	Min.	Ave.	Max.	Min.	Ave.
Contact resistance	5.4	5.2	5.31	5.5	5.2	5.29

N=20

Test item	Housing-Contact		Contact-Contact	
	Initial	After test	Initial	After test
Insulation resistance	10000 min.	5000 min.	10000 min.	5000 min.

N=10

Test item	Housing-Contact		Contact-Contact	
	Initial	After test	Initial	After test
D.W.V.*	Good	Good	Good	Good

N=10

\* D.W.V.: Dielectric withstanding voltage



# J.S.T.

TEST REPORT  
VH CONNECTOR  
(PHOSPHOR BRONZE)

TE-2204

Revised: D

ECN No. 0364

This is our exclusive property. It is not to be copied, reprinted, or disclosed to a third party, nor used for manufacturing, without our written consent, and has to be returned to us.

## 6.4.4 Heat Aging

Requirements: Contact resistance shall be 20 milliohms max. after the test.

Test method: A mated connector shall be placed in a heat oven of the following conditions. After the test, contact resistance shall be measured.

Temperature:  $85 \pm 2$  °C  
Period: 250 hours continuously

Test results:

Test item	Initial			After test		
	Max.	Min.	Ave.	Max.	Min.	Ave.
Contact resistance	5.5	5.2	5.35	5.5	5.2	5.35

(mΩ)  
N=20

## 6.4.5 Thermal Shock

Requirements: Contact resistance shall be 20 milliohms max. after the test. Insulation resistance shall be 500 megohms min. after the test. There shall be no breakdown nor flashover on the dielectric withstanding voltage test.

Test method: A mated connector shall be subjected to a thermal shock test of the following conditions. After the test, contact resistance, insulation resistance and dielectric withstanding voltage shall be measured.

1 cycle consists of:  
-25 0/-3 °C for 30 minutes  
+85 +3/0 °C for 30 minutes  
Times of cycles: 25 cycles

Test results:

Test item	Initial			After test		
	Max.	Min.	Ave.	Max.	Min.	Ave.
Contact resistance	5.5	5.1	5.32	5.5	5.1	5.35

(mΩ)  
N=20

Test item	Housing-Contact		Contact-Contact	
	Initial	After test	Initial	After test
Insulation resistance	10000 min.	5000 min.	10000 min.	5000 min.

(MΩ)  
N=10

Test item	Housing-Contact		Contact-Contact	
	Initial	After test	Initial	After test
D.W.V.*	Good	Good	Good	Good

N=10

\* D.W.V.: Dielectric withstanding voltage



# J.S.T.

TEST REPORT  
VH CONNECTOR  
(PHOSPHOR BRONZE)

TE-2204

Revised: D

ECN No. 0364

This is our exclusive property. It is a trade secret and its use without our written consent, and has to be returned to us.

## 6.4.6 Salt Spray

Requirements: Contact resistance shall be 20 milliohms max. after the test.

Test method: A mated connector shall be subjected to a salt spray test of the following conditions. After the test, the specimen shall be washed with running water and dried naturally before the measurement of contact resistance.

Temperature:  $35 \pm 2$  °C  
Density: 5 % in weight  
Period: 48 hours

Test results:

Test item	Initial			After test		
	Max.	Min.	Ave.	Max.	Min.	Ave.
Contact resistance	5.4	5.2	5.23	5.5	5.2	5.29

(mΩ)  
N=20

## 6.4.7 Hydrogen Sulfide Gas

Requirements: Contact resistance shall be 20 milliohms max. after the test.

Test method: A mated connector shall be subjected to hydrogen sulfide gas of the following conditions. After the test, contact resistance shall be measured.

Density:  $3 \pm 1$  ppm  
Temperature: 40 °C  
Period: 96 hours continuously

Test results:

Test item	Initial			After test		
	Max.	Min.	Ave.	Max.	Min.	Ave.
Contact resistance	5.5	5.3	5.34	5.4	5.3	5.33

(mΩ)  
N=20

\* Data show the values after 240 hours.



# J.S.T.

TEST REPORT  
VH CONNECTOR  
(PHOSPHOR BRONZE)

TE-2204

Revised: D

ECN No. 0364

This is our exclusive property. It is not to be copied, reprinted, or disclosed to a third party, nor used for manufacturing, without our written consent, and has to be returned to us.

#### 6.4.8 Ammonia Gas

Requirements: There shall be no defect such as crack caused by season cracking.

Test results: A mated connector shall be placed in a desiccator to be subjected to an ammonia gas test of the following conditions.

Ammonia solution: 1 % in weight  
Solution volume: 25 ml per one liter of desiccator volume  
Period: 72 hours

Test results: There was no defect. N=10

#### 6.4.9 Solderability

Requirements: Plating surface of solder-dipping section shall be covered with smooth solder.

Test method: Fluxed soldering section of header shall be dipped in solder of the following conditions.

Solder temperature:  $230 \pm 5$  °C  
Immersion period:  $3 \pm 0.5$  seconds  
Flux: Rosin (25%) methanol solution

Test results: Good. N=10

#### 6.4.10 Resistance to Soldering Heat

Requirements: There shall be no deformation nor damage which may affect the performance.

Test method: A specimen shall be mounted on a PCB (inserted only) and subjected to a resistance to soldering heat test of the following conditions.

Solder temperature:  $260 \pm 5$  °C  
Immersion period:  $5 \pm 0.5$  seconds

Test results: Good. N=10

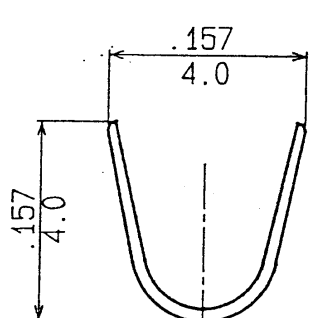
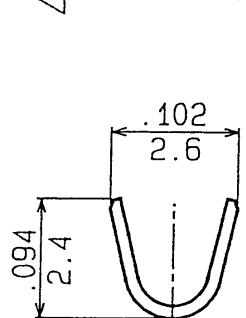
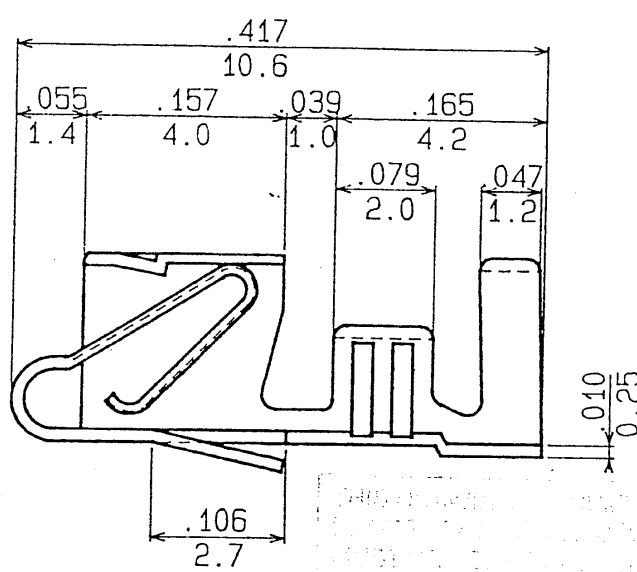
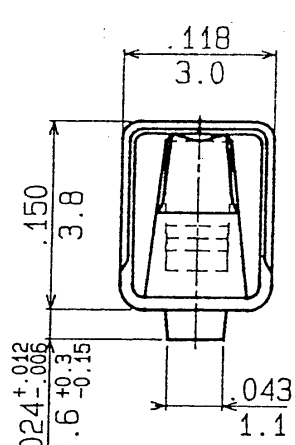
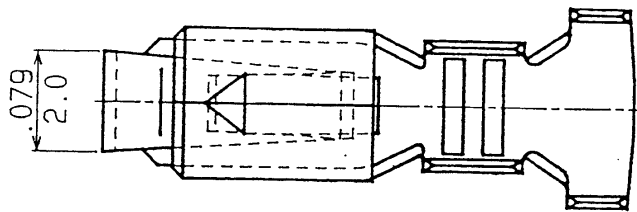

**NOTE**

1. Unless otherwise specified, tolerances are:  
 L= 0-.197/5.0: ±.012/±0.3  
 L=.201/5.1~ : ±.016/±0.4

2. Dimensions are in INCH/MM.

WIRE BARREL

INSULATION BARREL

				REVISIONS		① ... 91.11.5 Y.0	
CONTACT		PHOSPHOR ±.010 BRONZE to .25	TIN-PLATED				
No.	NAME	MATERIAL	REMARKS				
J. S. T.				PART NAME	VH CONNECTOR		
APPROVED BY	CHECKED BY	DRAWN BY	SCALE	PROJECTION	DATE	PART No.	SVH-21T-P1.1
NH	KM	Y.O	3rd		Aug. 25 1991	DRAWING No.	KRD-4711-2
						ISSUE	

THIS DRAWING CONTAINS INFORMATION THAT IS PROPRIETARY TO JST AND SHOULD NOT BE USED WITHOUT WRITTEN PERMISSION.

PI-E0070

0891011000N

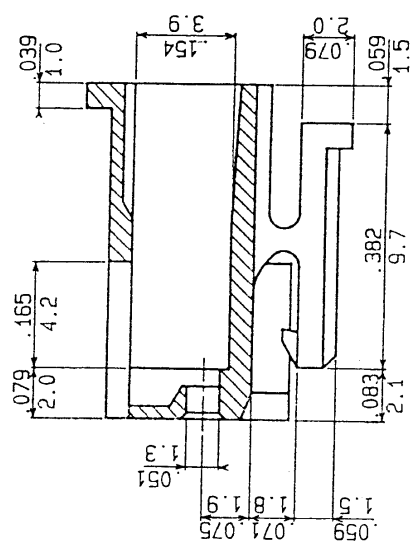
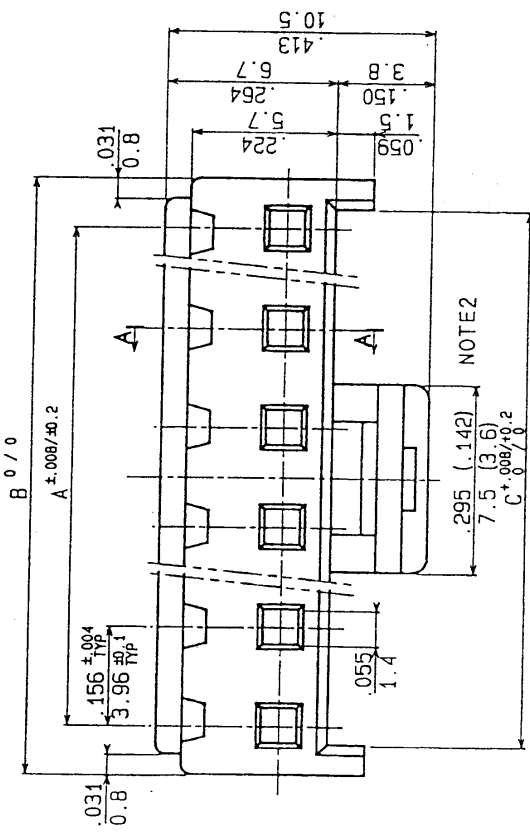

A-A SEC

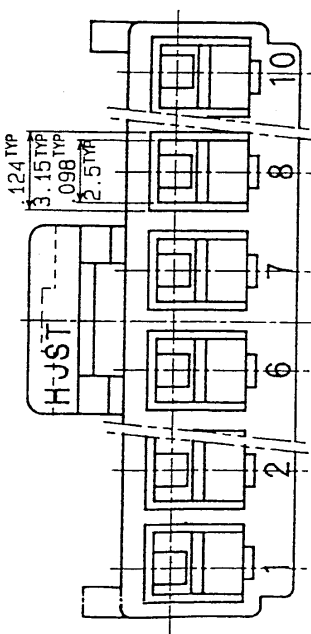
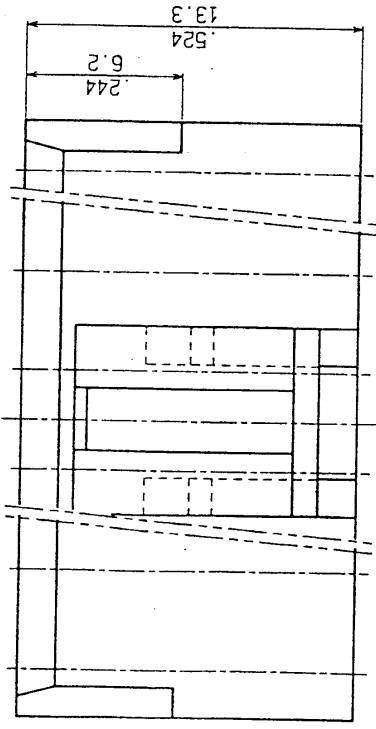

10	1.403/35.64	1.557/39.54	1.462/37.14
9	1.247/31.68	1.401/35.58	1.306/33.18
8	1.091/27.72	1.245/31.62	1.150/29.22
7	.935/23.76	1.089/27.66	.994/25.26
6	.780/19.80	.933/23.70	.839/21.30
5	.624/15.84	.777/19.74	.683/17.34
4	.468/11.88	.621/15.78	.527/13.38
3	.312/7.92	.465/11.82	.371/9.42
2	.156/3.96	.309/7.86	.215/5.46
CIR- CULTS	A	B	C

NOTE

1. Unless otherwise specified, tolerances are  $\pm .012/\pm 0.3$ .
2. ( ) dimension is for 2-circuit housing.
3. Dimensions are in INCH/MM.

REVISIONS		PART NAME		VH CONNECTOR	
HOUSING		6 NYLON		UL94V-0	
NAME		MATERIAL		REMARKS	
APPROVED BY		DRAWN BY		DATE	
J. S. I.		Y. O.		JUN. 7 1991	
CHECKED BY		SCALE		PROJECTION	
H. S.		1/1		3rd	
PART No.		PART No.		DRAWING No.	
VHR-( ) N		KRD--		3934-2	
ISSUE		KRD--		3934-2	

THIS DRAWING CONTAINS INFORMATION THAT IS PROPRIETARY TO JST AND SHOULD NOT BE USED WITHOUT WRITTEN PERMISSION.

PT-50070

E.C.109-0

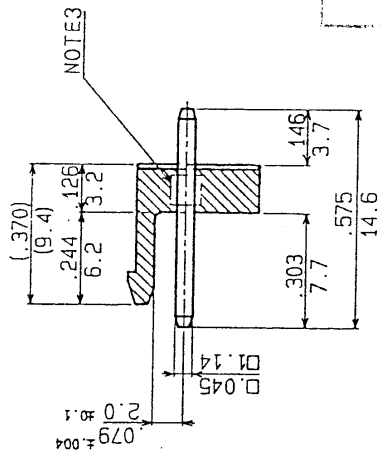
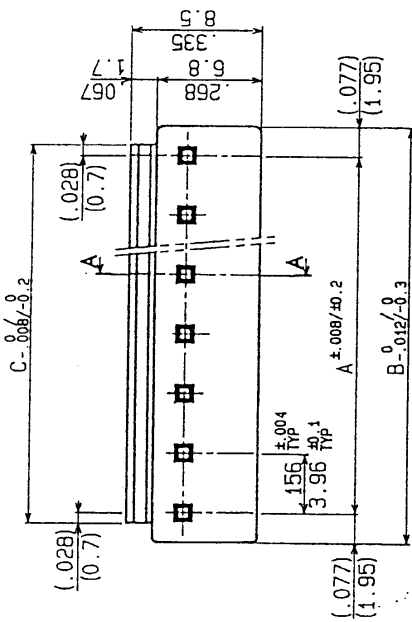

NOTE 3

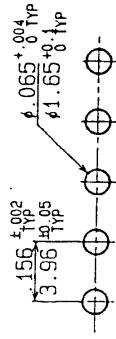

P.C BOARD HOLE LAYOUT

A-A SEC.

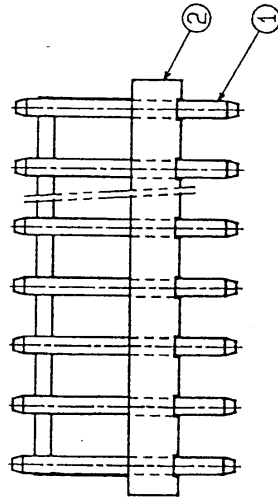

10	1.403/35.64	1.557/39.54	1.458/37.04
9	1.247/31.68	1.401/35.58	1.302/33.08
8	1.091/27.72	1.245/31.62	1.146/29.12
7	.935/23.76	1.089/27.66	.991/25.16
6	.780/19.80	.933/23.70	.835/21.20
5	.624/15.84	.777/19.74	.679/17.24
4	.468/11.88	.621/15.78	.523/13.28
3	.312/ 7.92	.465/11.82	.367/ 9.32
2	.156/ 3.96	.309/ 7.86	.211/ 5.36
cutouts	A	B	C

NOTE

1. Unless otherwise specified, tolerances ±.012/±0.3.
2. The deviation at the top of post shall be ±.006/±0.15.
3. Hatching part with holding construction.
4. Dimensions are in INCH/MM.

2	WAFER	66 NYLON	UL94V-0	REVISIONS
1	POST	BRASS	Copper-undepiatted Tin-platted	
No.	NAME	MATERIAL	REMARKS	
APPROVED BY	CHECKED BY	J. S. T.		
DATE	PROJECTION	SCALE	DATE	
Jun. 7 1991	3rd		Jun. 7 1991	
PART NAME	VH CONNECTOR			
PART No.	B ( ) P-VH			
DRAWING NO.	KRD-3933-2			

THIS DRAWING CONTAINS INFORMATION THAT IS PROPRIETARY TO JUST AND SHOULD NOT BE USED WITHOUT WRITTEN PERMISSION.

EC4109-0 PI-50070

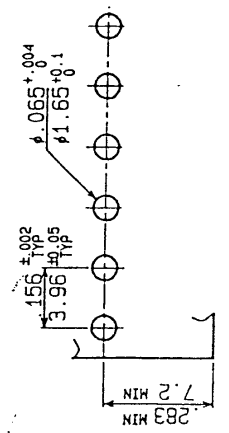
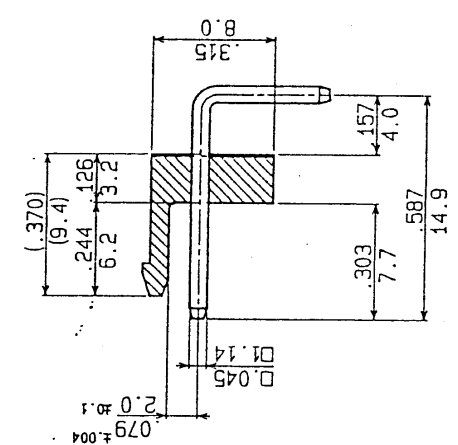
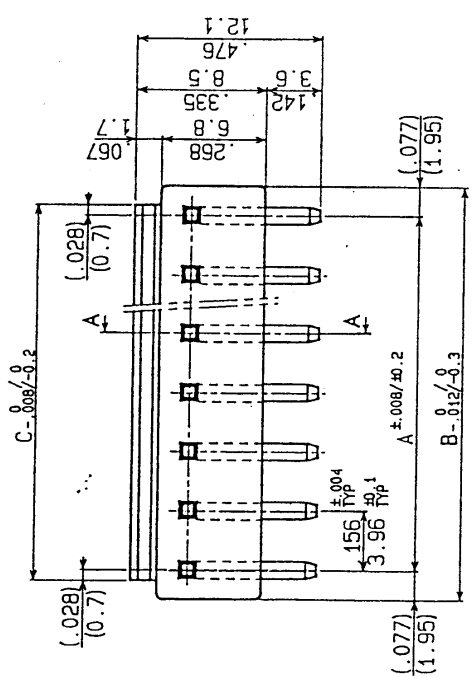

P.C BOARD HOLE LAYOUT.

A-A SEC

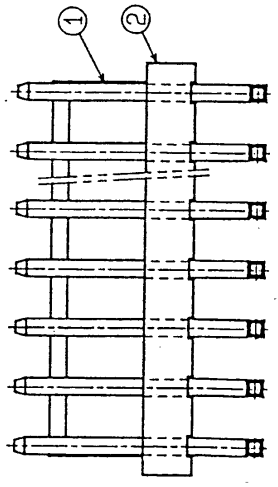

10	1.403/35.64	1.557/39.54	1.458/37.04
9	1.247/31.68	1.401/35.58	1.302/33.08
8	1.091/27.72	1.245/31.62	1.146/29.12
7	.935/23.76	1.089/27.66	.991/25.16
6	.780/19.80	.933/23.70	.835/21.20
5	.624/15.84	.777/19.74	.679/17.24
4	.468/11.88	.621/15.78	.523/13.28
3	.312/7.92	.465/11.82	.367/9.32
2	.156/3.96	.309/7.86	.211/5.36
cuts	A	B	C

THIS DRAWING IS PROPERTY OF J.S.T. AND SHOULD NOT BE USED WITHOUT WRITTEN PERMISSION.

2	WAFER	66 NYLON	UL94V-0
1	POST	BRASS	COPPER-UNDERPLATED IN-PLATED
No.	NAME	MATERIAL	REMARKS
APPROVED BY	CHECKED BY	DRAWN BY	J. S. T.
77	MM	Y.O	
SCALE	PRODUCTION	DATE	
	3rd	JUN. 11 1991	
REVISIONS	PART NAME	PART NO.	ISSUE
	VH CONNECTOR	B( )PS-VH	
	DRAWING NO.	KRD-4098-2	

- NOTE.
1. Unless otherwise specified, tolerances ±.012/±0.3.
  2. The deviation at the top of post shall be ±.006/±0.15.
  3. Dimensions are in INCH/MM.

THIS DRAWING CONTAINS INFORMATION THAT IS PROPRIETARY TO JST AND SHOULD NOT BE USED WITHOUT WRITTEN PERMISSION.

E.C.1109-0 PF-50070