

PH CONNECTOR

Disconnectable Crimp style connectors

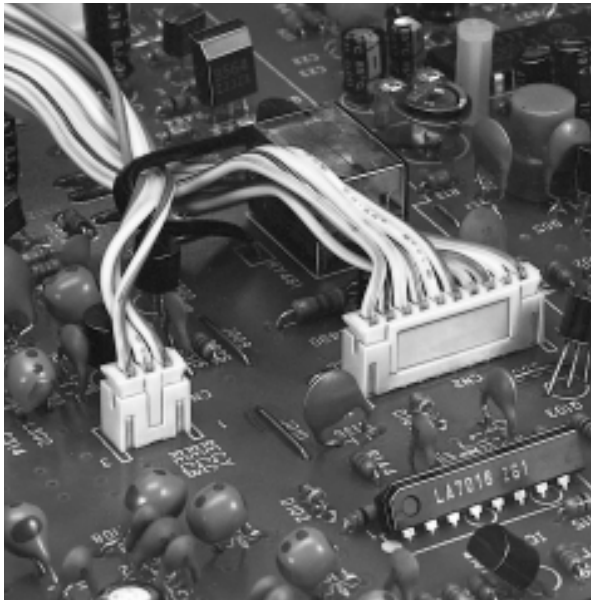

This is a thin, low-profile 2.0mm (.079") pitch connector 7.5mm (.295") in height after mounting and 4.5mm (.177") in width. It is designed to meet the demand for high-density connection of internal wires to printed circuit boards. It is compact, highly reliable and low in cost.

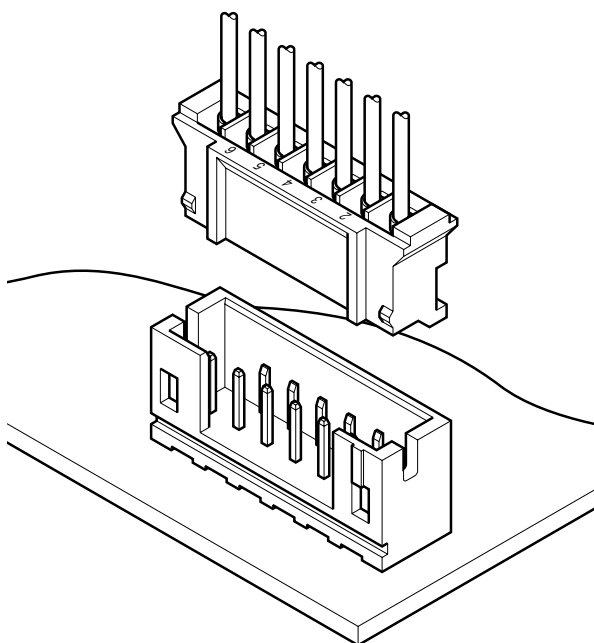

Features

• **Reliable contact**

The contact has long dimples near the center to ensure a good connection at all times, even under conditions of vibration and mechanical abuse, and when used with low voltage and low current circuits.

• **Easy and effective crimping**

Although the contact is compact, it has a long wire strip holding length of 2.6 +/- 0.4mm (.102" +/- .016"). This long length simplifies automatic crimping and the crimping of shielded wires.

• **Fully shrouded header**

The fully shrouded header has walls on all four sides to prevent improper connection to the mating housing and to prevent the intrusion of flux and other contaminants.

• **High solderable square post**

The square post is copper-undercoated and tin/lead-plated for superior solderability and for whisker prevention.

• **Printed circuit board retention mechanism**

The solder side of the header has a retention mechanism that prevents it from floating during soldering. As a result, the header can be positioned accurately.

• **Compatible with the KR insulation displacement connector**

The same shrouded header can be used for either PH crimp-style connector or KR insulation displacement connector. This allows both types of connector to be used interchangeably without replacing the header.

• **Surface mount model (SMT)**

This connector is also available in a surface mount configuration. Its housing is made of heat resistant resin so that it is not adversely affected during reflow soldering. Because of its tiny size and ability to be surface mounted, this connector meets the demand for high-density mounting of components inside electronic products.

Specifications

- Current rating: 2A AC, DC (AWG #24)
- Voltage rating: 100V AC, DC
- Temperature range: -25°C to +85°C
(including temperature rise in applying electrical current)
- Contact resistance: Initial value/10m Ω max.
After environmental testing/20m Ω max.
- Insulation resistance: 1,000M Ω min.
- Withstanding voltage: 800V AC/minute
- Applicable wire: AWG #32 to #24
- Applicable PC board thickness: 0.8 to 1.6mm (.031" to .063")
- * Contact JST if Lead-Free product is required.
- * Refer to "General Instruction and Notice when using Terminals and Connectors" at the end of this catalog.
- * Contact JST for details.

Standards

- Recognized E60389
- 1 Certified LR20812
- 2 R75087

REV	DESCRIPTION	DATE	DESIGNED
1			

Part No.	A	B	C	16	15	14	13	12	11	10	9	8	7	6	5	4	3	2	1
16 S16B-PH-K-S (LF) (SN)	30.0	33.9	32.6	OK1	OK1	OK1	OK1	OK1	OK1	OK1	OK1	OK1	OK1	OK1	OK1	OK1	OK1	OK1	OK1
15 S15B-PH-K-S (LF) (SN)	28.0	31.9	30.6	OK1	OK1	OK1	OK1	OK1	OK1	OK1	OK1	OK1	OK1	OK1	OK1	OK1	OK1	OK1	OK1
14 S14B-PH-K-S (LF) (SN)	26.0	29.9	28.6	OK1	OK1	OK1	OK1	OK1	OK1	OK1	OK1	OK1	OK1	OK1	OK1	OK1	OK1	OK1	OK1
13 S13B-PH-K-S (LF) (SN)	24.0	27.9	26.6	OK1	OK1	OK1	OK1	OK1	OK1	OK1	OK1	OK1	OK1	OK1	OK1	OK1	OK1	OK1	OK1
12 S12B-PH-K-S (LF) (SN)	22.0	25.9	24.6	OK1	OK1	OK1	OK1	OK1	OK1	OK1	OK1	OK1	OK1	OK1	OK1	OK1	OK1	OK1	OK1
11 S11B-PH-K-S (LF) (SN)	20.0	23.9	22.6	OK1	OK1	OK1	OK1	OK1	OK1	OK1	OK1	OK1	OK1	OK1	OK1	OK1	OK1	OK1	OK1
10 S10B-PH-K-S (LF) (SN)	18.0	21.9	20.6	OK1	OK1	OK1	OK1	OK1	OK1	OK1	OK1	OK1	OK1	OK1	OK1	OK1	OK1	OK1	OK1
9 S9B-PH-K-S (LF) (SN)	16.0	19.9	18.6	OK1	OK1	OK1	OK1	OK1	OK1	OK1	OK1	OK1	OK1	OK1	OK1	OK1	OK1	OK1	OK1
8 S8B-PH-K-S (LF) (SN)	14.0	17.9	16.6	OK1	OK1	OK1	OK1	OK1	OK1	OK1	OK1	OK1	OK1	OK1	OK1	OK1	OK1	OK1	OK1
7 S7B-PH-K-S (LF) (SN)	12.0	15.9	14.6	OK1	OK1	OK1	OK1	OK1	OK1	OK1	OK1	OK1	OK1	OK1	OK1	OK1	OK1	OK1	OK1
6 S6B-PH-K-S (LF) (SN)	10.0	13.9	12.6	OK1	OK1	OK1	OK1	OK1	OK1	OK1	OK1	OK1	OK1	OK1	OK1	OK1	OK1	OK1	OK1
5 S5B-PH-K-S (LF) (SN)	8.0	11.9	10.6	OK1	OK1	OK1	OK1	OK1	OK1	OK1	OK1	OK1	OK1	OK1	OK1	OK1	OK1	OK1	OK1
4 S4B-PH-K-S (LF) (SN)	6.0	9.9	8.6	OK1	OK1	OK1	OK1	OK1	OK1	OK1	OK1	OK1	OK1	OK1	OK1	OK1	OK1	OK1	OK1
3 S3B-PH-K-S (LF) (SN)	4.0	7.9	6.6	OK1	OK1	OK1	OK1	OK1	OK1	OK1	OK1	OK1	OK1	OK1	OK1	OK1	OK1	OK1	OK1
2 S2B-PH-K-S (LF) (SN)	2.0	5.9	4.6	OK1	OK1	OK1	OK1	OK1	OK1	OK1	OK1	OK1	OK1	OK1	OK1	OK1	OK1	OK1	OK1

Table 1
CLINCHED PINS DETAILS
K1, K2, 0: POST UNCLINCHED

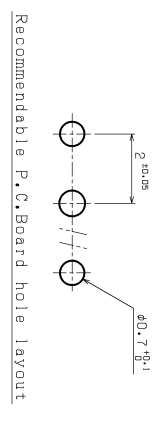
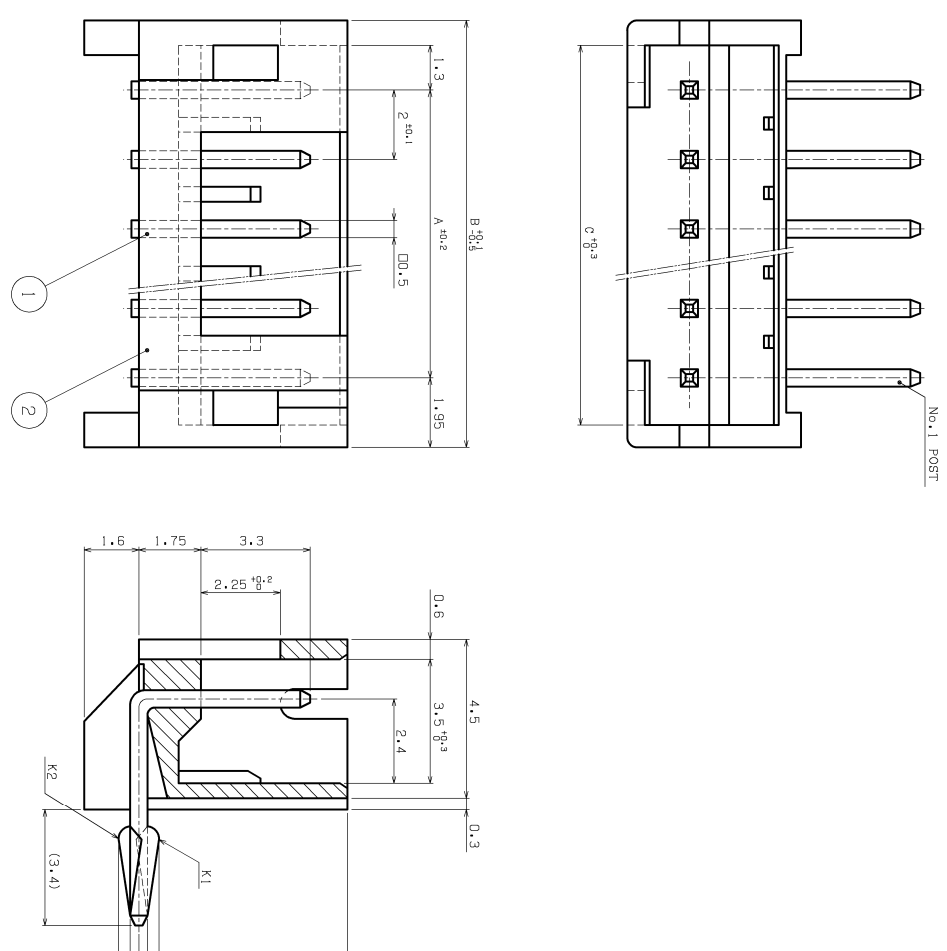

Recommendable P.C. Board hole layout

NOTE
1. Unless otherwise specified, tolerances are ±0.3
2. Clinched pins directions and locations are shown table 1.
3. Tolerance of hole pitch on PCB are not cumulative.

2	WAFER	GSNYLON																			
1	POST	BRASS																			
No. 1		PART NAME		MATERIAL		PRODUCTION DATE		CUSTOMER		SERIES NAME		PART No.		DRAWING No.		REV		DATE		DESIGNED	
A2		SCALE		PRODUCTION DATE		CUSTOMER		SERIES NAME		PART No.		DRAWING No.		REV		DATE		DESIGNED		REMARKS	
METRIC 10:1		1/8"		JAN. 6.2005		UL94V-0, NATURAL		PH, KR CONNECTOR		S () B-PH-K-S (LF) (SN)		KPD-35429		RD							
S.K		T.S		N.H																	

JST J.S.T.MFG.CO.,LTD.
ECL113-2

THIS DRAWING CONTAINS INFORMATION THAT IS PROPRIETARY TO J.S.T. AND SHOULD NOT BE USED WITHOUT WRITTEN PERMISSION.