

# Connectors according to DIN 41612 / IEC 60603-2

## Type C/2

Female connector

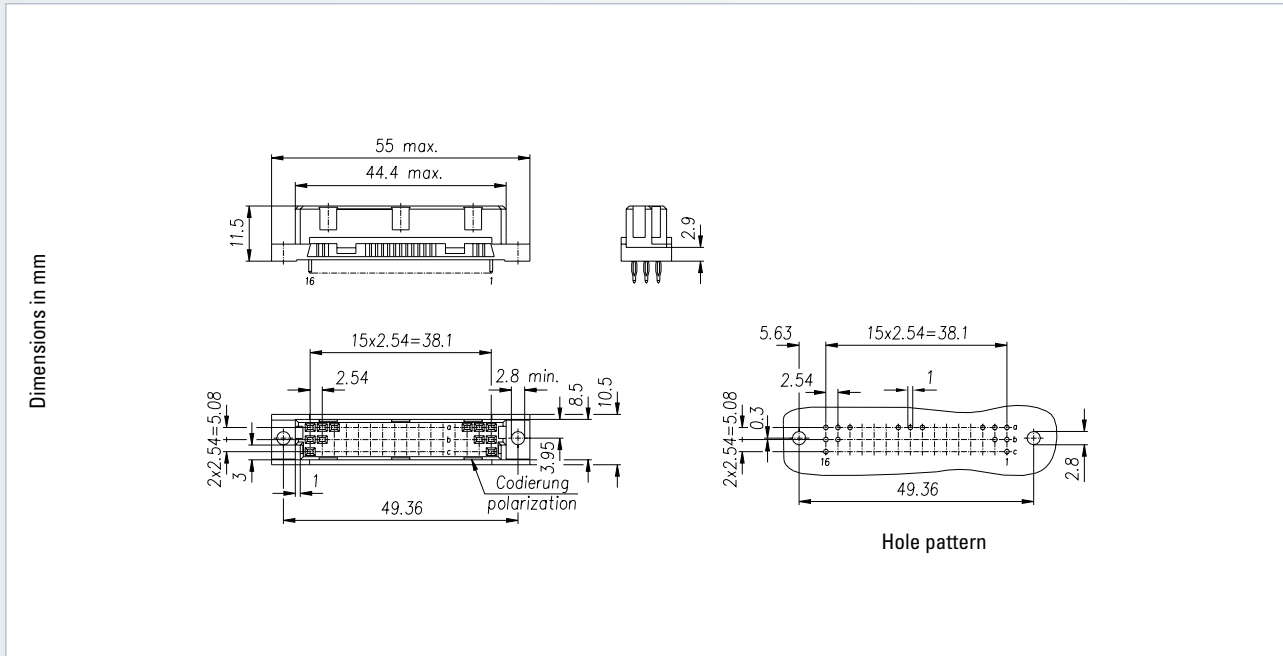
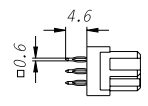
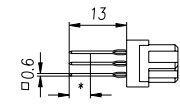
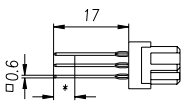
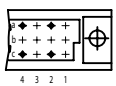
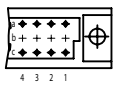
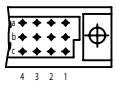

No. of contacts	Contact arrangement	Press-fit technology – Performance level II		
		Termination length		
				
Part number				
16		104-69004-xx	104-79006-xx	104-79106-xx
32		304-69014-02	304-79016-03	304-79116-04
48		304-69064-02	304-79066-03	304-79166-04

<b>Accessories</b> – Press-fit tool (see page 208) – Support tool (see page 209) – Coding accessories (see page 160)	<b>On request</b> – Performance levels I + III or customer-specific – Special contact length – Alternative surface Sn, e.g. for WireWrap	<b>Options</b> – Without flange – Contact arrangement (see page 162)
<b>Note</b> – * Rear mating zone Ni, Au	<b>Ordering note</b> Only for 104 – PCB 1.5 to 2.0 mm = xxx-xxxx-01 termination length = 3.2 mm – PCB 2.0 to 2.8 mm = xxx-xxxx-02 termination length = 4.6 mm – PCB > 2.8 mm = xxx-xxxx-03 termination length = 4.6mm	

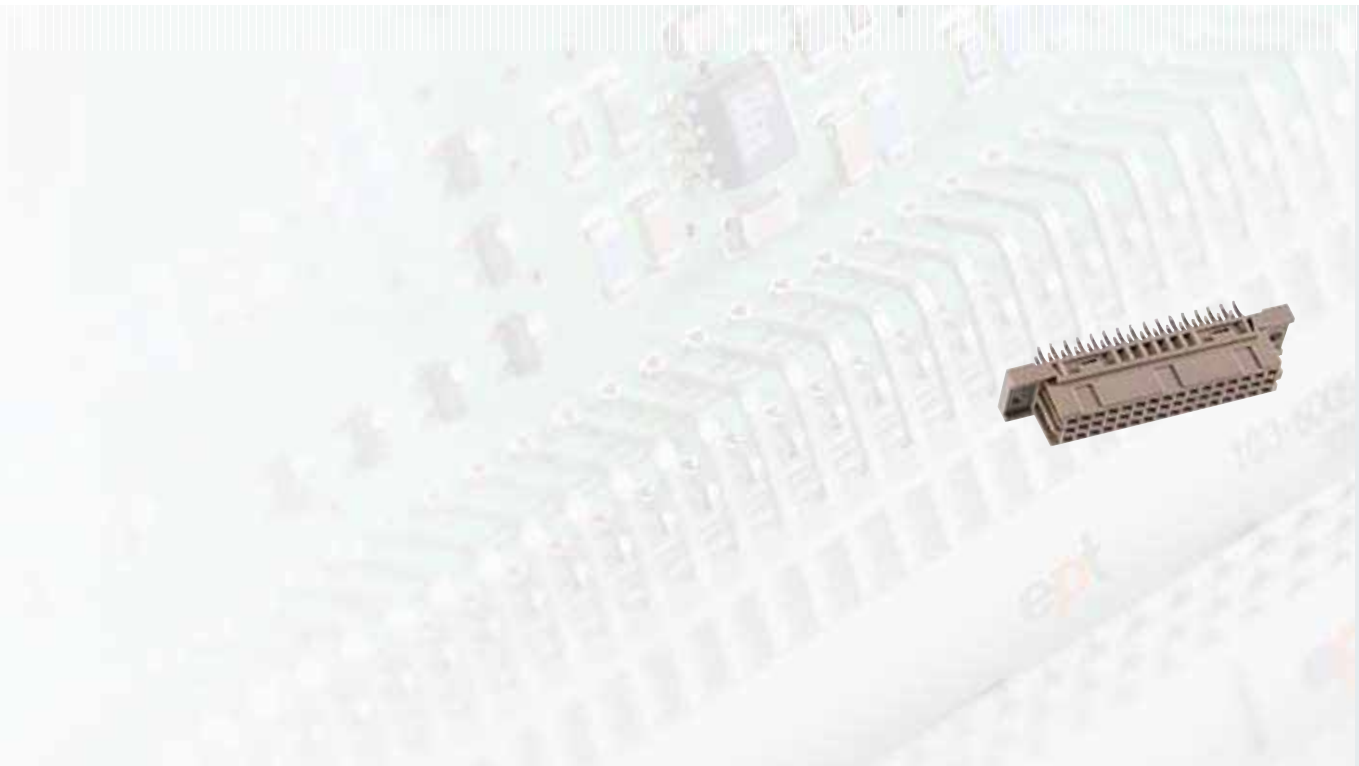

No. of contacts	Contact arrangement	Solder technology – Performance level II				
		Termination length				
						Manual soldering with solder lug 
Part number						
16		104-90004	–	–	104-90006	104-90025
32		304-90014-05	304-90014-01	304-90014-02	304-90016-03	104-90035
48		304-90064-05	304-90064-01	304-90064-02	304-90066-03	104-90075

<p><b>Accessories</b></p> <ul style="list-style-type: none"> <li>– Coding accessories (see page 160)</li> </ul>	<p><b>On request</b></p> <ul style="list-style-type: none"> <li>– Performance levels I + III or customer-specific</li> <li>– Special contact length</li> <li>– Also in THTR</li> </ul>	<p><b>Options</b></p> <ul style="list-style-type: none"> <li>– Board lock (see page 159)</li> <li>– Contact arrangement (see page 162)</li> </ul>
---	--	---