

MI20/21 Series

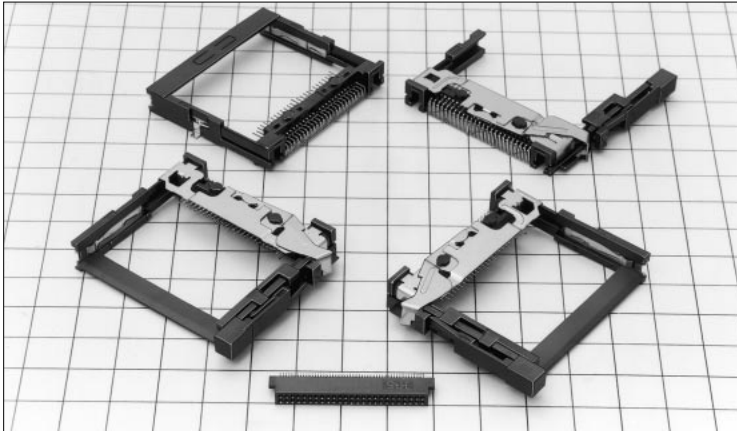

■ Features

1. Compact design occupies minimum space

Connectors are designed with small width and depth for miniaturization and the foot print on the board has been made smaller. (See (a) to the right)

2. Supplied with ground terminals

The MI21 Series are furnished with ground terminals.

3. Card ejection mechanism

Two point ejection mechanism to assure even card ejection.

4. Designed and packaged for board placement with automatic equipment

Headers are designed with a pick up area to accommodate the pick-and-place nozzles of automatic mounting machines. (Patents pending)

Receptacles are designed to be mounted on top the board, and automatic mounting is possible on the specified board.

5. Card ejection mechanism

Available in several termination and mounting styles, with and without ejection mechanism, with and without stand-offs.

6. Rich variations

A rich assortment of variations allows selection of a type to suit the specific card and the equipment to which it will be installed.

- (1) Suitable cards: Type I, type I/II.
- (2) Eject button: None, right, left
- (3) Standoff: 0 mm, 2.2 mm
- (4) Board mounting type: Standard, reverse

(a) Space-saving design

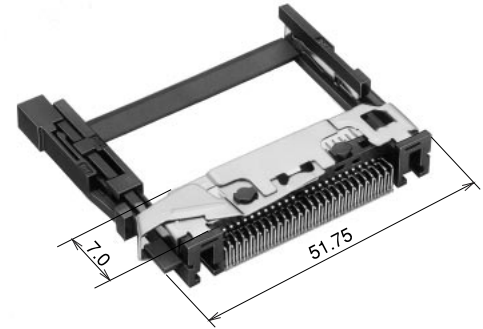

(b) Suitable for automatic mounting

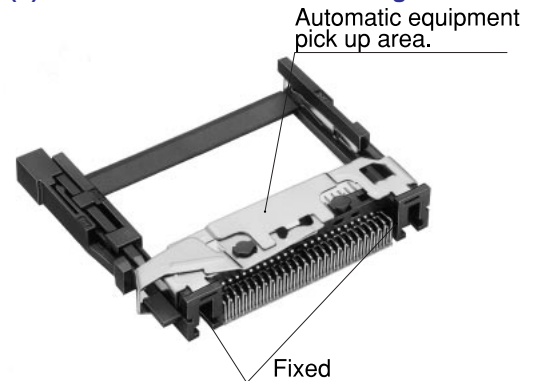

HRS Product Feature

Fixed fittings make slider immobile.



Construction facilitates pick-and-place process.

● Product Variation

Series	Mounting	offset	Ejector	Cards	Built-in nuts
MI20	Standard	None	None	Type I or II	—
		2.2mm	Right Left	Type I	YES
	Reverse	2.2mm	None	Type I	Δ(Note)
MI21	Standard	0mm	Right Left	Type I or II	YES
		2.2mm	None		
	Reverse	0mm	None		

Note 1: Hexagonal nuts (M2×0.4) are required.

■ Applications

PDA, digital still cameras, etc.

■ Card Receptacle

Rating	Rated current Rated voltage	0.5 A 125 V AC	Operating temperature range Operating humidity range	-55 to +85°C (Note 1) Relative humidity 95% or less (No condensation)	Storage temperature range Storage humidity range	-10 to +60°C 40 to 70%
--------	--------------------------------	-------------------	---	---	---	---------------------------

Item	Requirements	Conditions
1. Insulation resistance	1,000 MΩ or greater	Measured at 500 V DC
2. Voltage proof	No flashover or insulation breakdown	500 V AC applied for one minute
3. Contact resistance	40 mΩ or less (initial value) (Note 2)	Measured at 1 mA
4. Vibration	No electrical discontinuity for 100 ns or greater	Frequency: 10 to 2000 Hz, single amplitude of 1.52 mm or acceleration of 147 m/s ² (peak) in 3 directions, 4 hours each
5. Damp heat (Steady state)	Insulation resistance of 100 MΩ or greater	Temperature of 40 ±2°C, humidity of 90 to 95%, duration 96 h
6. Rapid change of temperature	Insulation resistance of 100 MΩ or greater	Temperature: -55°C for 30 min. --> +5 to 35°C within 5 min. 85°C for 30 min. --> +5 to 35°C within 5 min. for 5 cycles
7. Mechanical operation	Change of contact resistance from initial value is 20 mΩ or less	10000 times (400 to 600 times per hour)
8. Resistance to soldering heat	No melting of resin portion which affects performance	Reflow: At the recommended temperature profile Soldering iron temperature: 300°C for 3 seconds

Note 1: Includes temperature rise when conducting.

Note 2: This does not include the resistance of the conductor .

■ Materials and Finishes

Item	Part	Material	Colour/Finish	Notes
Receptacle	Insulator	PPS resin	Black	UL94V-0
	Contacts	Phosphor bronze	Engagement Area : Gold plating of 0.1µm Termination Area : Solder plating	————
Header	Insulator	PPS resin	Black	UL94V-0
	Contacts	Brass	Engagement Area : Gold plating of 0.1µm Termination Area : Solder plating	————
	Reinforced fitting	Brass	————	Applied to eject mechanism
	Eject fitting	Stainless steel	————	————
	Ground clip	Stainless steel	————	Applied to MI21
	Nut	Steel	Solder plating	————

■ Product Number Composition

Please use this information to discern the product specifications from the product number codes.

To order, please select from the product number codes listed on pages C4 to C14 of this catalog.

● Receptacles

MI 20 - 50 RD - SF

① ② ③ ④ ⑤

① Series name: MI
② Series No.: 20
③ Number of contacts: 50
④ Connector type RD: Receptacle
⑤ Contact form SF: SMT

① Series name: MI	⑥ Board mounting type Blank : Standard R : Reverse
② Series No. 20: for type I cards (*) 21: for type I and II cards	⑦ Contact form SF: SMT
③ Standoff type Blank : None A : 2.2 mm	⑧ Eject button position EJR : Right button EJL : Left button Blank : None
④ Number of contacts: 50	⑨ Built-in nut type (31): With built-in nuts Blank: Standard product
⑤ Connector type PD: Header	

● Headers

MI 20 A - 50 PD R - SF - EJR (31)

① ② ③ ④ ⑤ ⑥ ⑦ ⑧ ⑨

(*) Can accommodate type II cards only when standard mounting is used and standoff is 0 mm.

■ Receptacle Dimensions

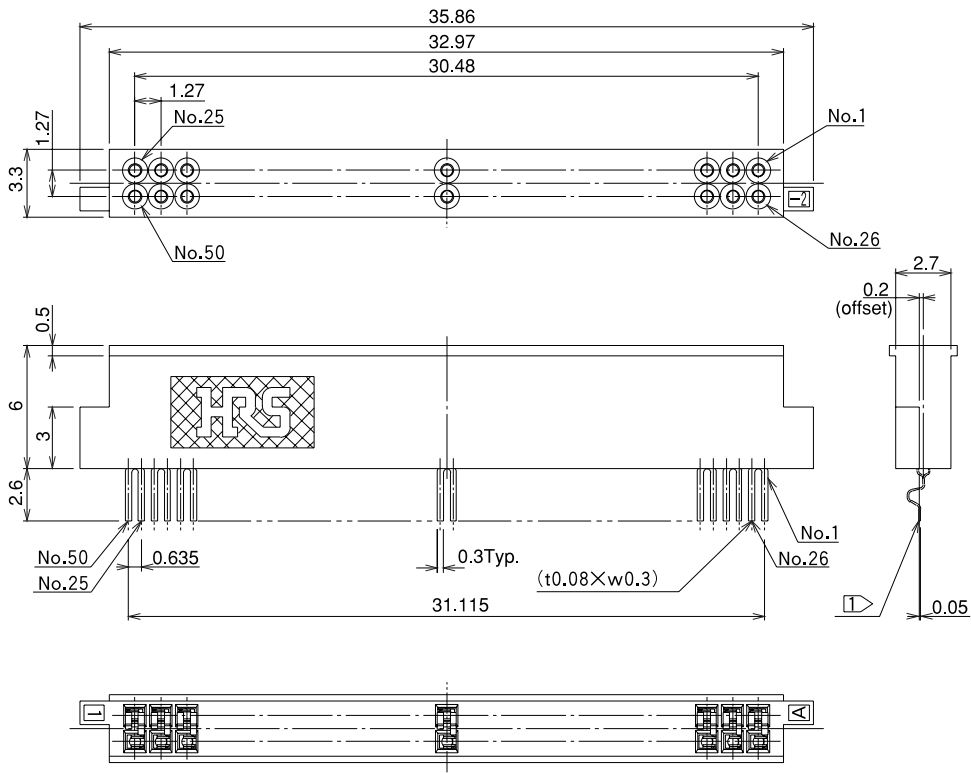

Note ① The coplanarity of the conductor is 0.1 mm Max.

Product No.	HRS No.	No. of contacts	Packaging
MI20-50RD-SF	CL640-7001-0	50	Tray

◆ Recommended PC Board Mounting and Cutout Dimensions

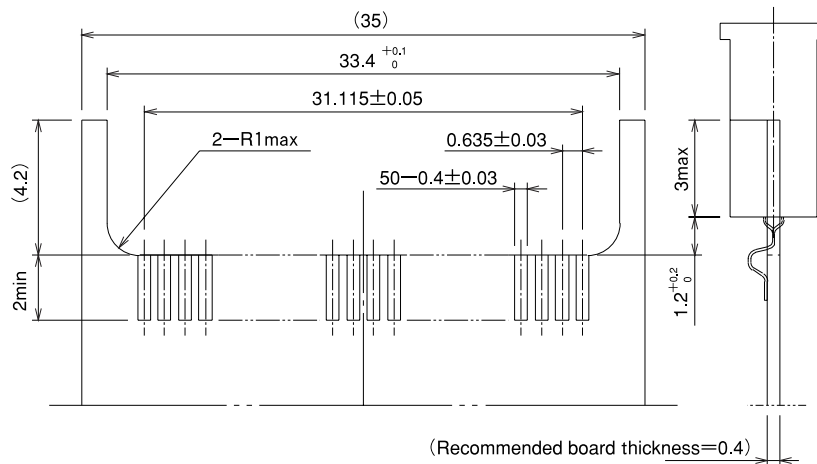

■ Headers for Type I or II Cards

- Eject button : None
- Offset : None
- Mounting style : Standard mounting

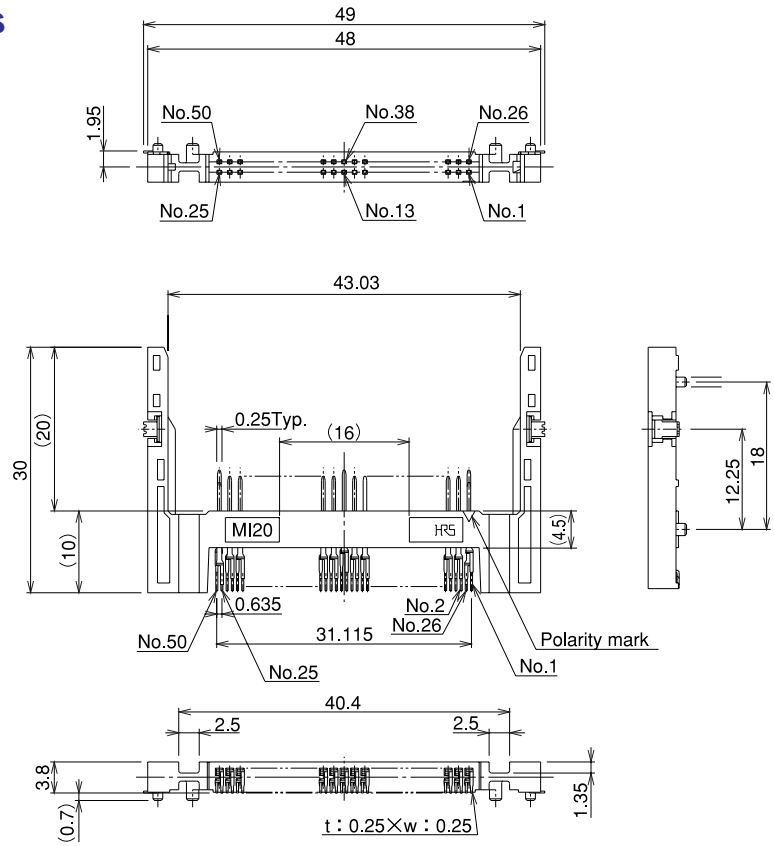

Note 1: Coplanarity of all surface mount terminals and components is 0.1.

Note 2: Dimensions in parentheses () are reference dimensions.

Product No.	HRS No.	No. of contacts	Packaging
MI20-50PD-SF	CL640-7002-2	50	Tray

◆ Recommended PC Board Mounting Pattern

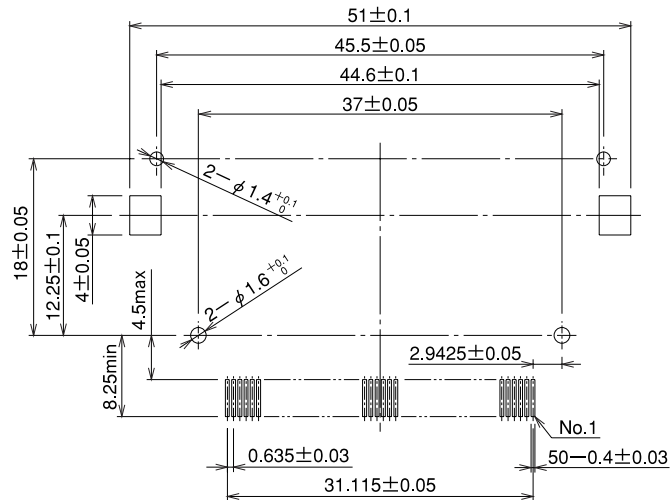

■ Headers for Type I Cards

- Eject button : None
- Offset : 8.5 mm
- Mounting style : Reverse mounting

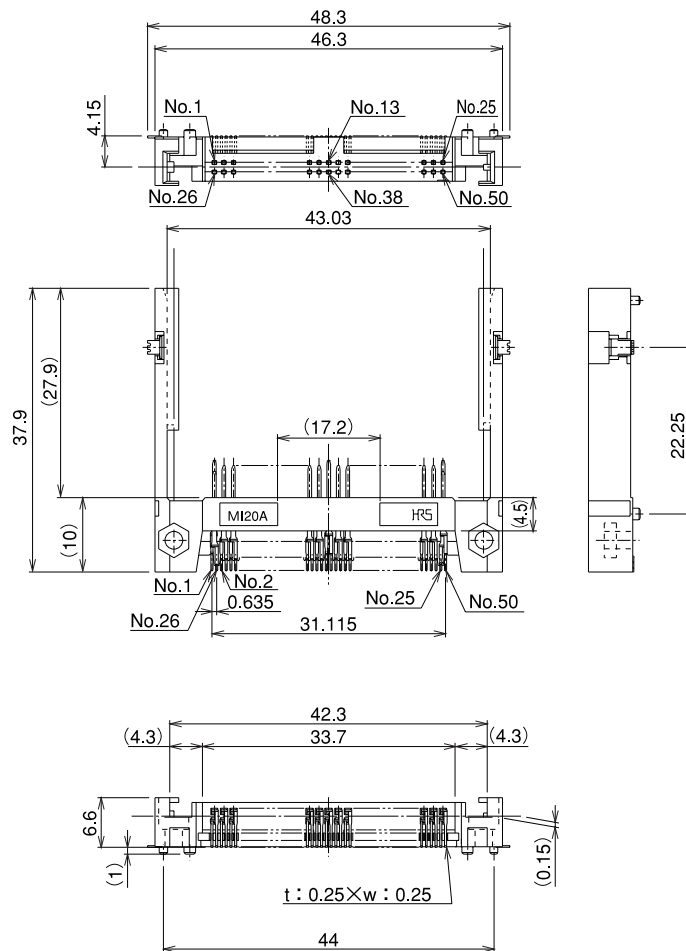

Note 1: Coplanarity of all surface mount terminals and components is 0.1.

Note 2: Dimensions in parentheses () are reference dimensions.

Product No.	HRS No.	No. of contacts	Packaging
MI20A-50PDR-SF	CL640-7003-5	50	Tray

◆ Recommended PC Board Mounting Pattern

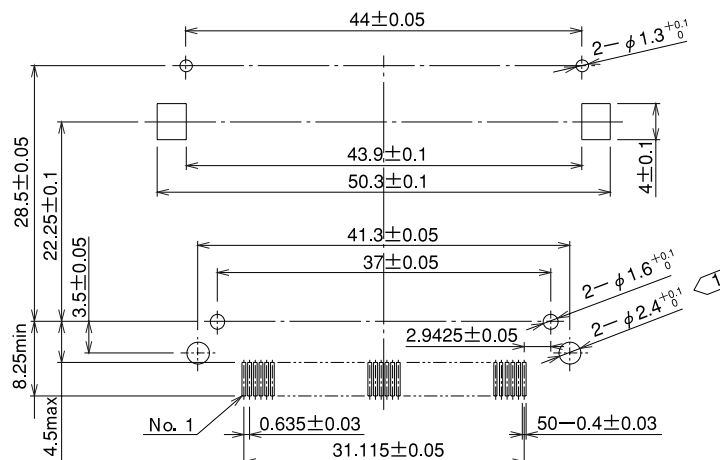

Note 1 The holes (2-φ2.4^{+0.1}) illustrated in the figure are only required when screws are used for fastening.

■ Headers for Type I Cards

- Eject button : Right button
- Offset : 2.2 mm
- Mounting style : Standard mounting

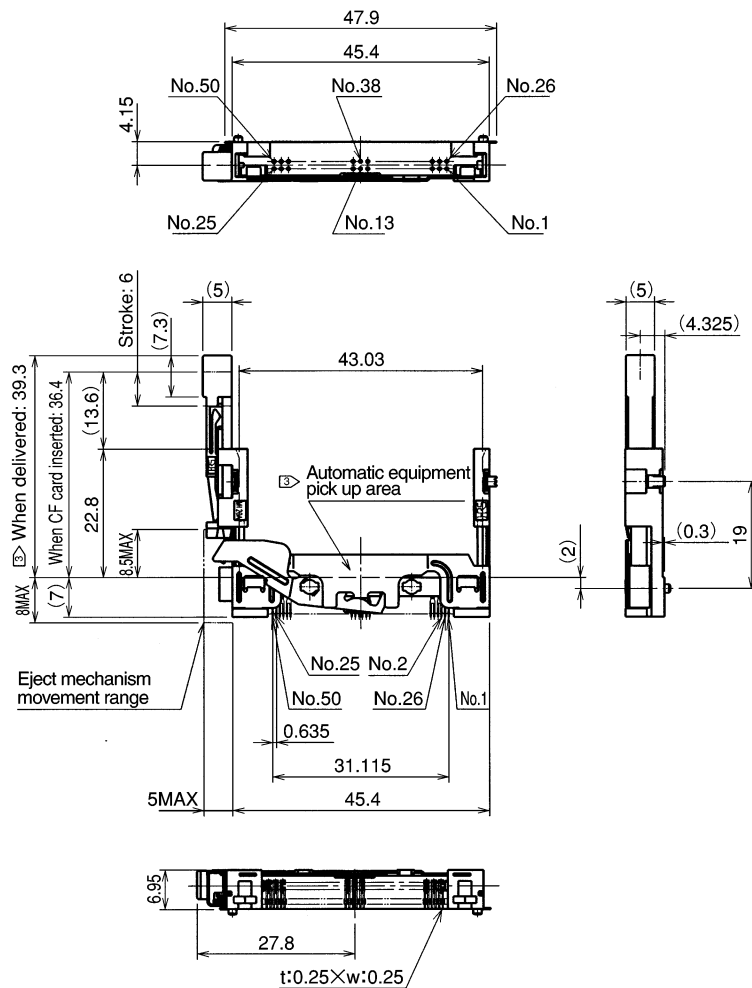

Note 1: The amount of card and button protrusion from the connector after mating is 13.6 mm.

Note 2: The dimensions of mating portion of this product comply with CFA standards.

Note 3: This product can be automatically mounted. The suction surface for automatic mounting is positioned as illustrated in the figure.

③ This part is fixed in the initial condition, but released with a single operation of the ejector.

(Amount of actual card ejection: 3.5 mm)

Note 4: The coplanarity (degree of flatness) of the SMT lead tip portion and the reinforced fitting mounting end face is to be 0.1 maximum.

Note 5: Dimensions in parentheses () are to be regarded as reference dimensions.

Product No.	HRS No.	No. of contacts	Packaging
MI20A-50PD-SF-EJR	CL640-7004-8	50	Tray

◆ Recommended PC Board Mounting Pattern

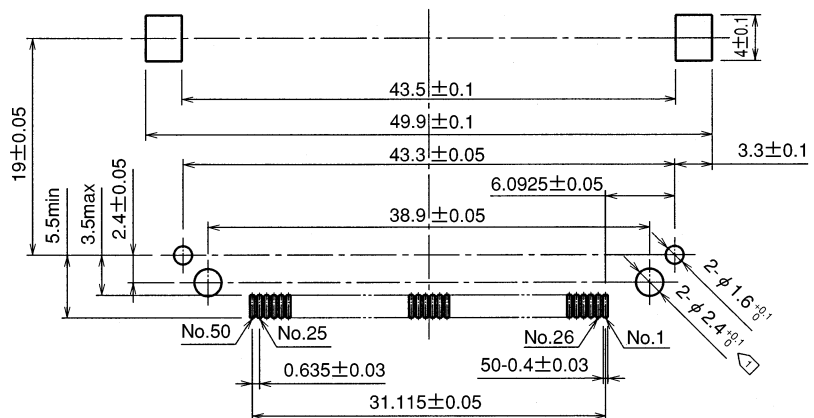

Note ① The holes ($2-\phi 2.4^{+0.1}_0$) illustrated in the figure are only required when screws are used for fastening.

■Headers for Type I Cards

- Eject button : Left side
- Offset : 2.2 mm
- Mounting style : Standard mounting

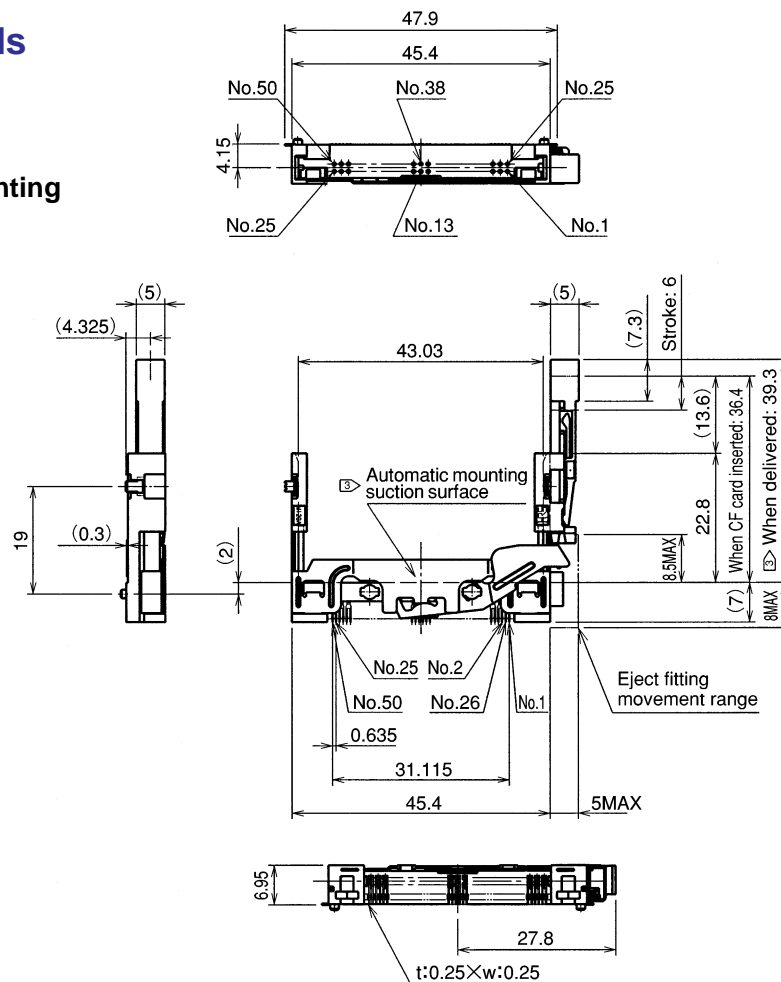

Note 1: The amount of card and button protrusion from the connector after mating is 13.6 mm.

Note 2: The dimensions of mating portion of this product comply with CFA standards.

Note 3: This product can be automatically mounted. The suction surface for automatic mounting is positioned as illustrated in the figure.

③ This part is fixed in the initial condition, but released with a single operation of the ejector.

(Amount of actual card ejection: 3.5 mm)

Note 4: The coplanarity (degree of flatness) of the SMT lead tip portion and the reinforced fitting mounting end face is to be 0.1 maximum.

Note 5: Dimensions in parentheses () are to be regarded as reference dimensions.

Product No.	HRS No.	No. of contacts	Packaging
MI20A-50PD-SF-EJL	CL640-7005-0	50	Tray

◆Recommended PC Board Mounting Pattern

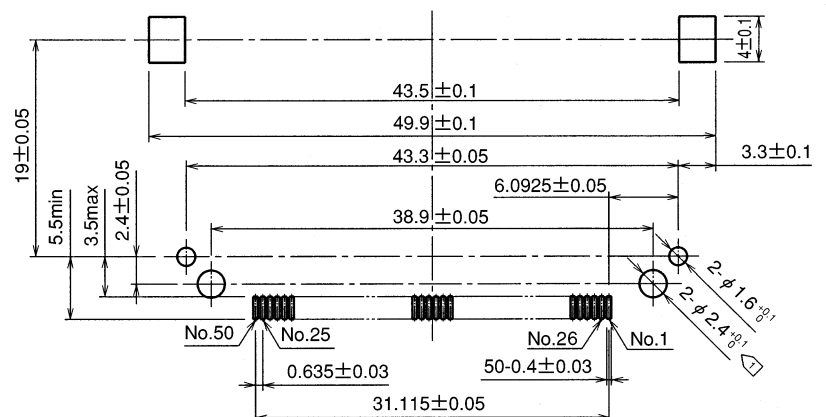

Note ① The holes ($2-\phi 2.4^{+0.1}$) illustrated in the figure are only required when screws are used for fastening.

■ Headers for Type I or II Cards

- Eject button : Right side
- Offset : 0 mm
- Mounting style : Standard mounting

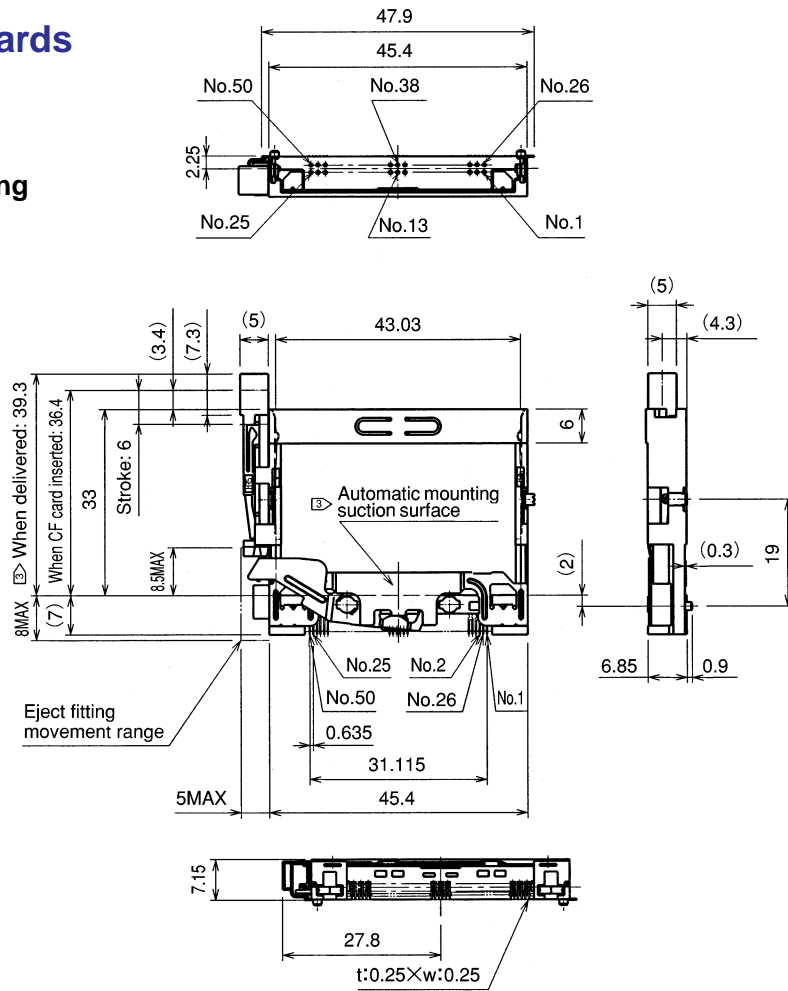

Note 1: This item is a (standard type) header for use with CompactFlash cards.

Note 2: The dimensions of mating portion of this product comply with CFA standards.

Note 3: This product can be automatically mounted. The suction surface for automatic mounting is positioned as illustrated in the figure.

③ This part is fixed in the initial condition, but released with a single operation of the ejector.

(Amount of actual card ejection: 3.5 mm)

Note 4: The coplanarity (degree of flatness) of the SMT lead tip portion and the reinforced fitting mounting end face is to be 0.1 maximum.

Note 5: Dimensions in parentheses () are to be regarded as reference dimensions.

Product No.	HRS No.	No. of contacts	Packaging
MI21-50PD-SF-EJR	CL640-7107-0	50	Tray

◆ Recommended PC Board Mounting Pattern

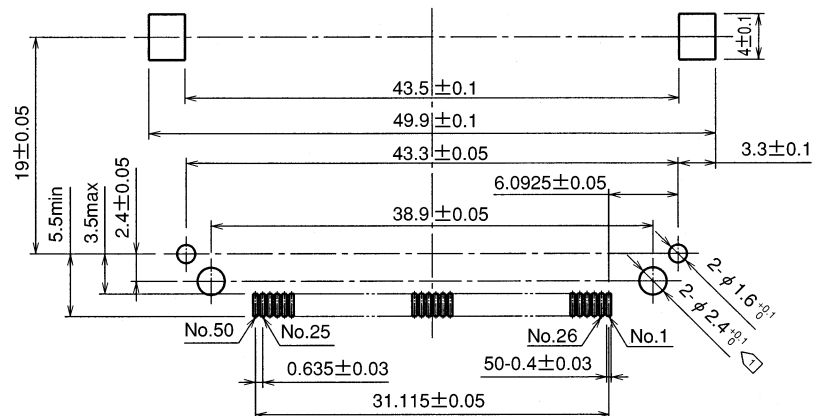

Note ① The holes ($2-\phi 2.4^{+0.1}$) illustrated in the figure are only required when screws are used for fastening.

■Headers for Type I or II Cards

- Eject button : Left side
- Offset : None
- Mounting style : Standard mounting

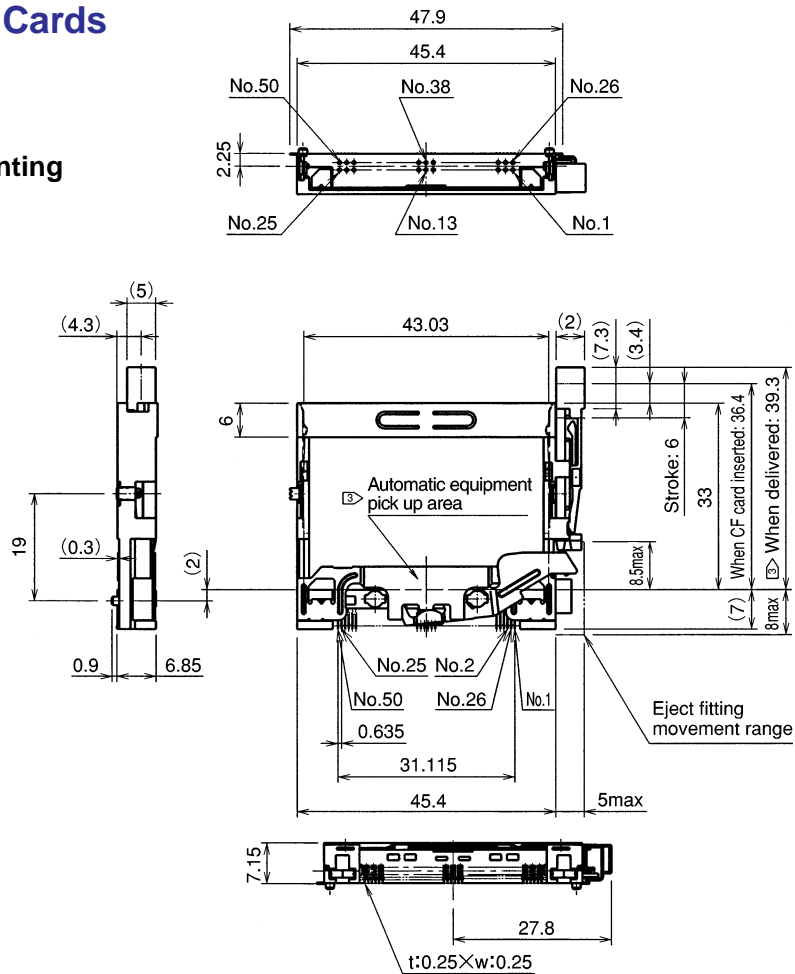

Note 1: This item is a (standard type) header for use with CompactFlash cards.

Note 2: The dimensions of mating portion of this product comply with CFA standards.

Note 3: This product can be automatically mounted. The suction surface for automatic mounting is positioned as illustrated in the figure.

③ This part is fixed in the initial condition, but released with a single operation of the ejector.

(Amount of actual card ejection: 3.5 mm)

Note 4: The coplanarity (degree of flatness) of the SMT lead tip portion and the reinforced fitting mounting end face is to be 0.1 maximum.

Note 5: Dimensions in parentheses () are to be regarded as reference dimensions.

Product No.	HRS No.	No. of contacts	Packaging
MI21-50PD-SF-EJL	CL640-7108-3	50	Tray

◆Recommended PC Board Mounting Pattern

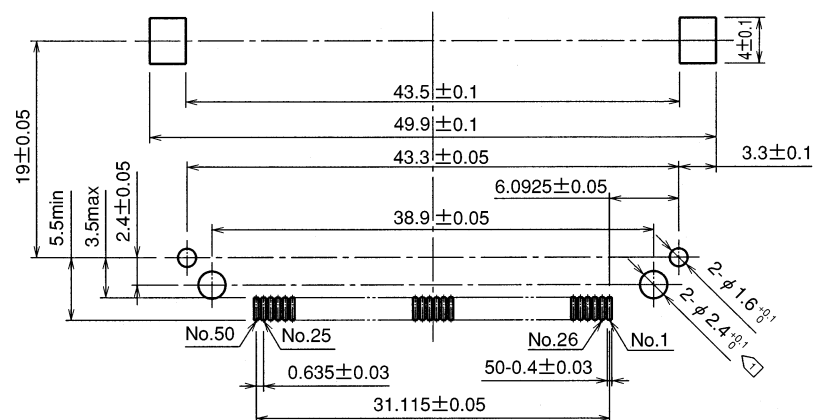

Note ① The holes ($2-\phi 2.4^{+0.1}$) illustrated in the figure are only required when screws are used for fastening.

■ Headers for Type I or II Cards

- Eject button : None
- Offset : None
- Mounting style : Standard mounting

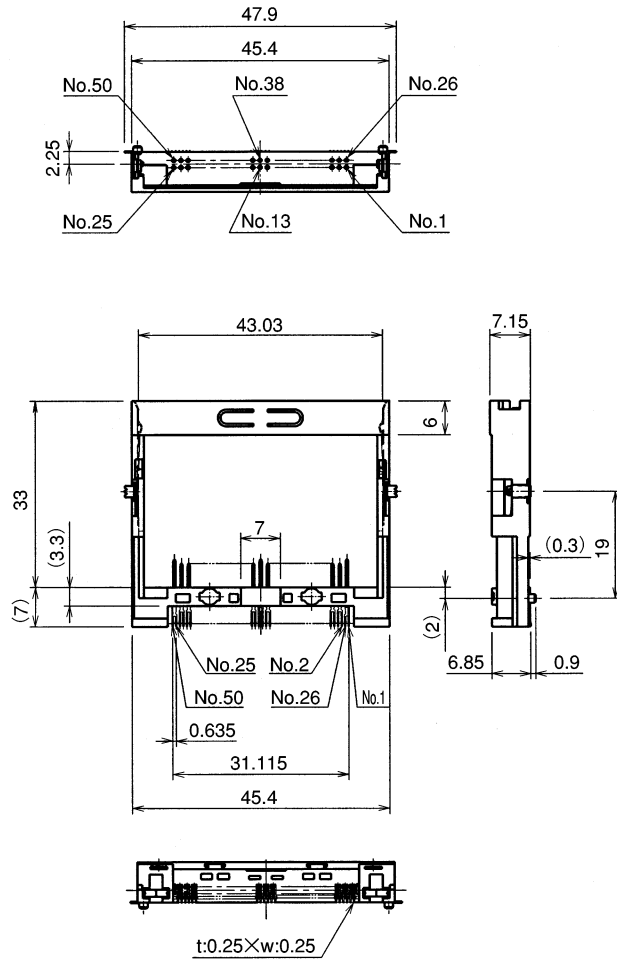

- Note 1: This item is a (standard type) header for use with CompactFlash cards.
 Note 2: The dimensions of mating portion of this product comply with CFA standards.
 Note 3: The coplanarity (degree of flatness) of the SMT lead tip portion and the reinforced fitting mounting end face is to be 0.1 maximum
 Note 4: Dimensions in parentheses () are to be regarded as reference dimensions.

Product No.	HRS No.	No. of contacts	Packaging
MI21-50PD-SF	CL640-7109-6	50	Tray

◆ Recommended PC Board Mounting Pattern

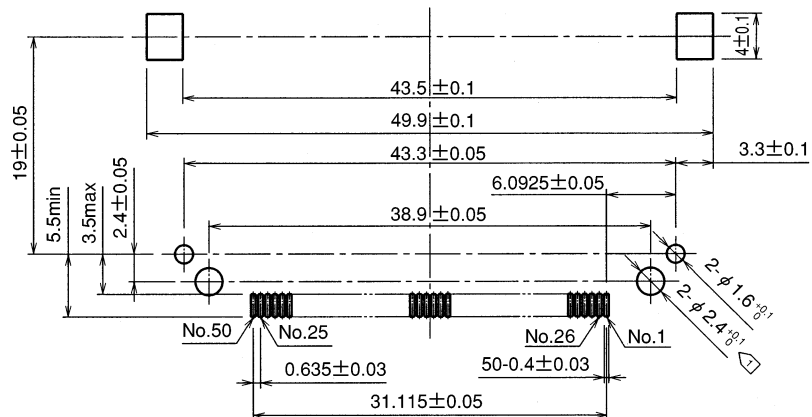

- Note 1) The holes (2-φ2.4 ± 0.1) illustrated in the figure are only required when screws are used for fastening.

■ Headers for Type I or II Cards

- Eject button : None
- Offset : None
- Mounting style : Reverse mounting

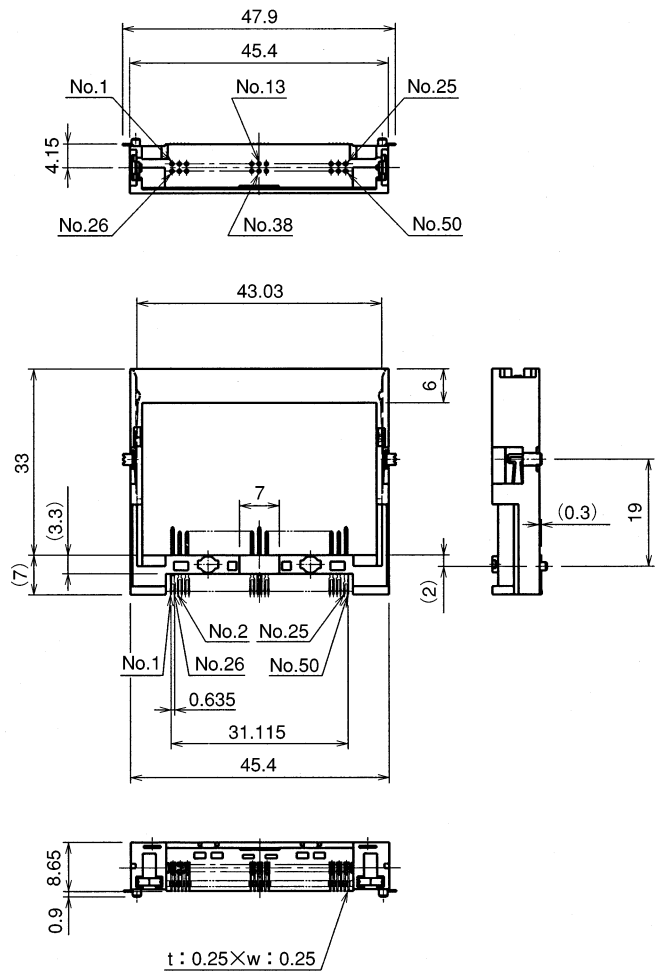

Note 1: Coplanarity of all surface mount terminals and components is 0.1.

Note 2: Dimensions in parentheses () are reference dimensions.

Product No.	HRS No.	No. of contacts	Packaging
MI21A-50PDR-SF	CL640-7106-8	50	Tray

◆ Recommended PC Board Mounting Pattern

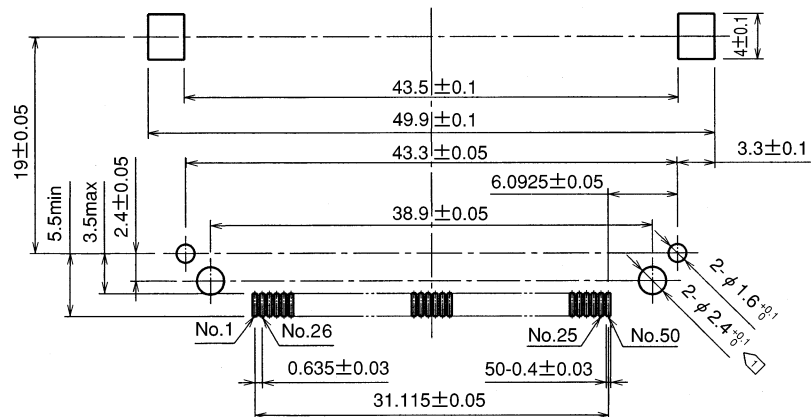

■Headers for Type I and II Cards

- Eject button : Right side
- Offset : 2.2 mm
- Mounting style : Standard mounting

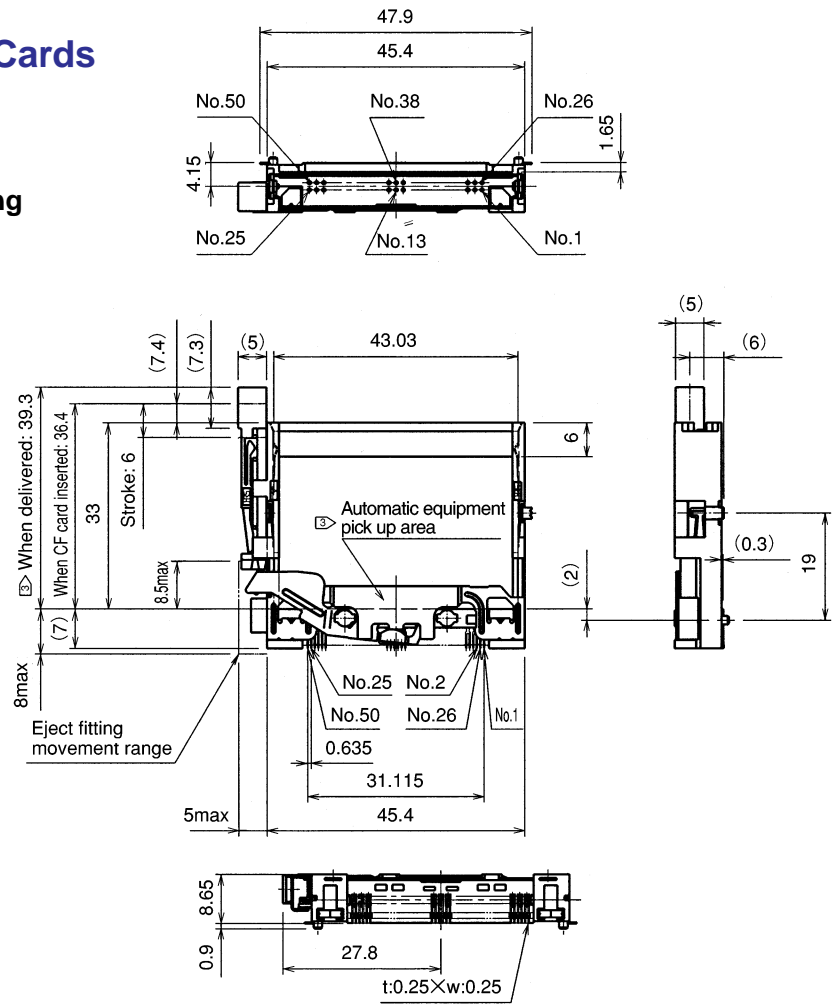

Note 1: This item is a (standard type) header for use with CompactFlash cards.

Note 2: The dimensions of mating portion of this product comply with CFA standards.

Note 3: This product can be automatically mounted. The suction surface for automatic mounting is positioned as illustrated in the figure.

③ This part is fixed in the initial condition, but released with a single operation of the ejector.

(Amount of actual card ejection: 3.5 mm)

Note 4: The coplanarity (degree of flatness) of the SMT lead tip portion and the reinforced fitting mounting end face is to be 0.1 maximum.

Note 5: Dimensions in parentheses () are to be regarded as reference dimensions.

Product No.	HRS No.	No. of contacts	Packaging
MI21A-50PD-SF-EJR	CL640-7101-4	50	Tray

◆Recommended PC Board Mounting Pattern

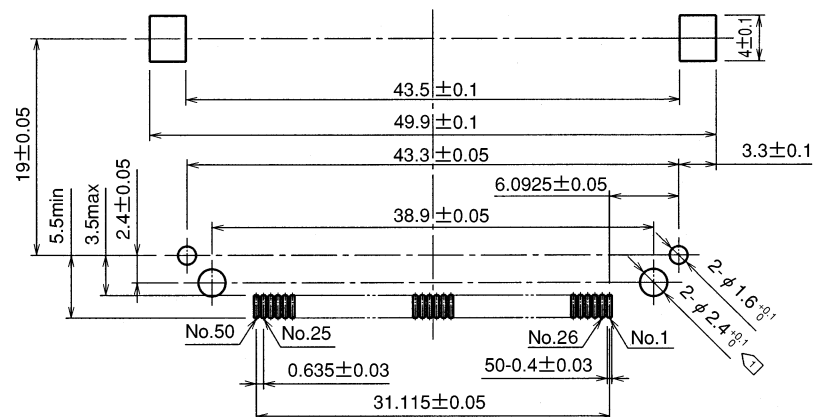

Note ① The holes ($2-\phi 2.4^{+0.1}$) illustrated in the figure are only required when screws are used for fastening.

■ Headers for Type I and II Cards

- Eject button : Left button
- Offset : 2.2 mm
- Mounting style : Standard mounting

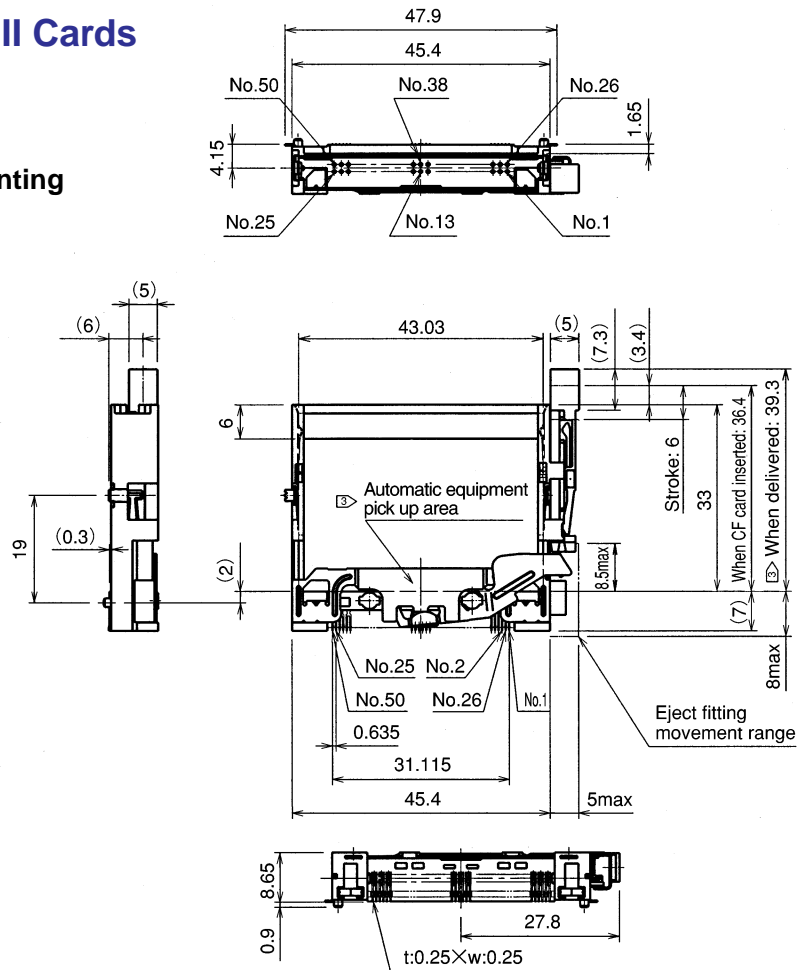

Note 1: This item is a (standard type) header for use with CompactFlash cards.

Note 2: The dimensions of mating portion of this product comply with CFA standards.

Note 3: This product can be automatically mounted. The suction surface for automatic mounting is positioned as illustrated in the figure.

③ This part is fixed in the initial condition, but released with a single operation of the ejector.

(Amount of actual card ejection: 3.5 mm)

Note 4: The coplanarity (degree of flatness) of the SMT lead tip portion and the reinforced fitting mounting end face is to be 0.1 maximum.

Note 5: Dimensions in parentheses () are to be regarded as reference dimensions.

Product No.	HRS No.	No. of contacts	Packaging
MI21A-50PD-SF-EJL	CL640-7102-7	50	Tray

◆ Recommended PC Board Mounting Pattern

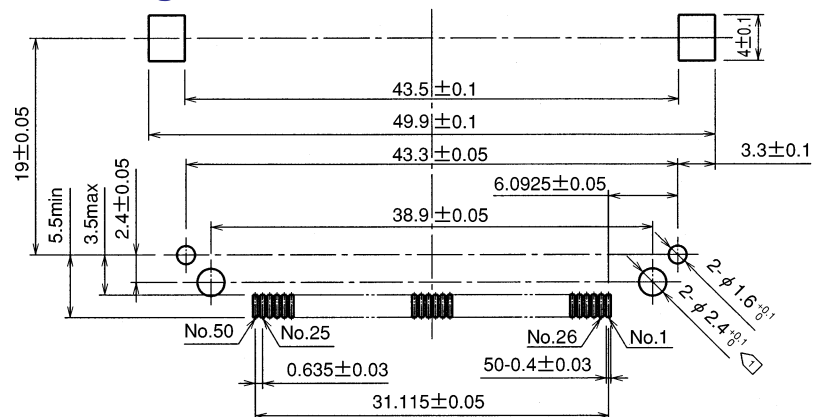

Note ① The holes (2-φ2.4^{+0.1}) illustrated in the figure are only required when screws are used for fastening.

■ Headers for Type I and II Cards

- Eject button : None
- Offset : 2.2 mm
- Mounting style : Standard mounting

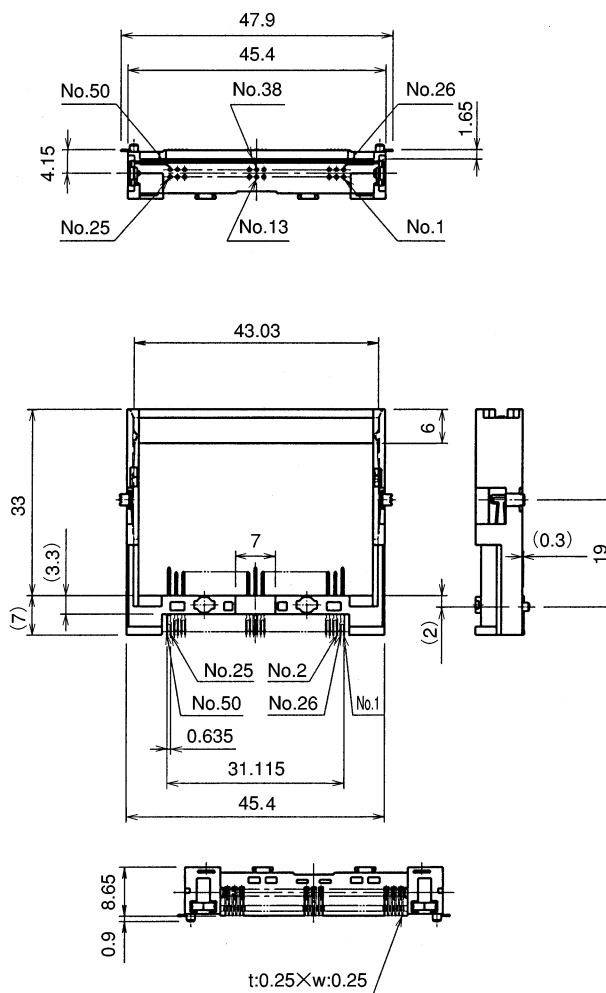

Note 1: Coplanarity of all surface mount terminals and components is 0.1.

Note 2: Dimensions in parentheses () are reference dimensions.

Product No.	HRS No.	No. of contacts	Packaging
MI21A-50PD-SF	CL640-7003-0	50	Tray

◆ Recommended PC Board Mounting Pattern

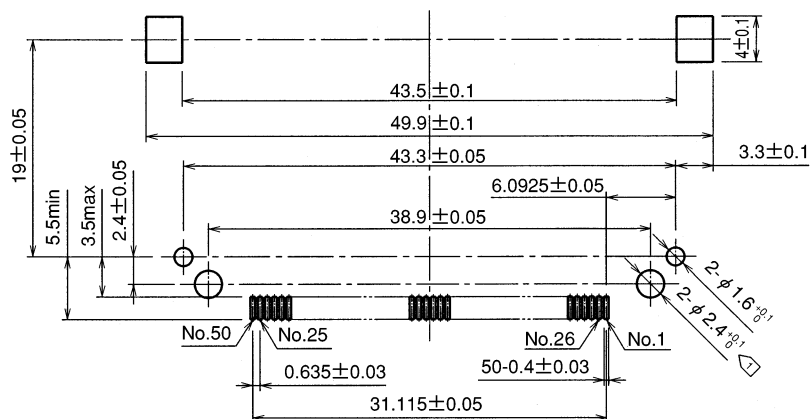

Note 1) The holes ($2-\phi 2.4^{+0.1}$) illustrated in the figure are only required when screws are used for fastening.

◆ Recommended Solder Temperature Profile

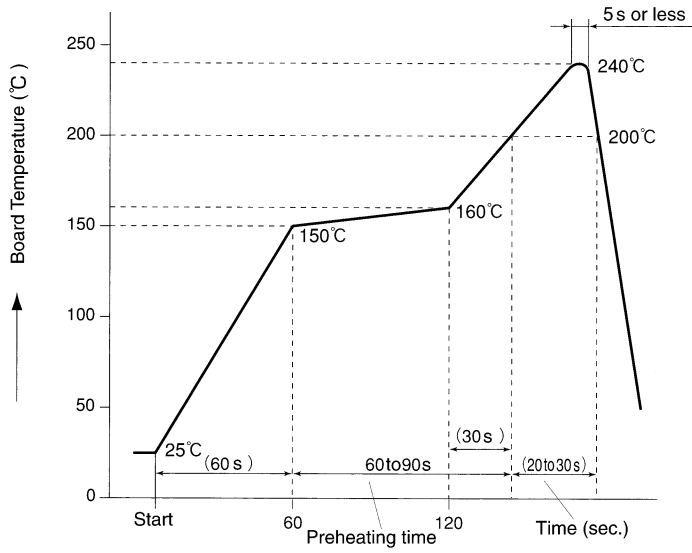

Applicable Conditions

Reflow method : IR

Solder type : Cream type 63Sn/37Pb
(Flux component of 9wt%)

Test substrate : Glass epoxy 60 x 60 x 1.6mm

Metal mask thickness : 0.15mm

The actual solder temperature profile may vary, depending on type and amount of solder cream.

◆ Handling Precautions

1. Differentiate the side of the card at the time of CF card insertion. This product is furnished with an wrong insertion prevention mechanism which is compliant with CFA standards, but forced wrong insertion of the card may cause damage to the card.
2. Do not move the CF card up and down when it has been partially inserted. It may cause damage to the connector and card.

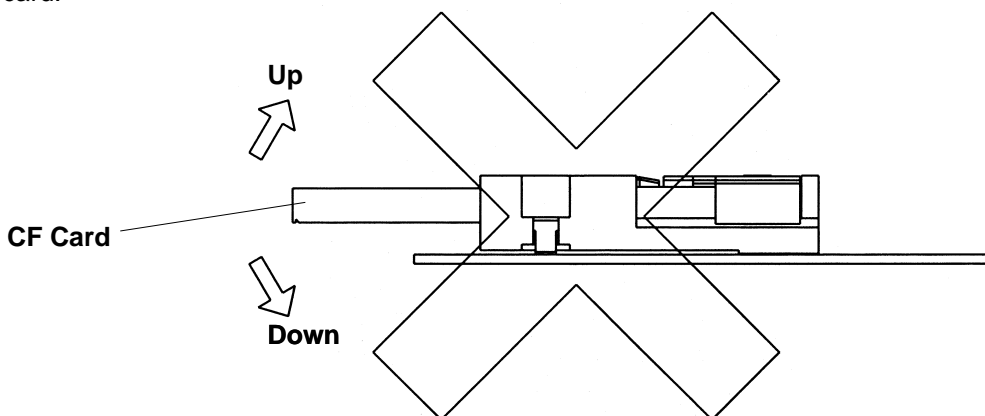

3. The package used for this product is the soft tray. We recommend a check before mounting, since the adjustment may be required depending on the type of mounter. For more detailed information, please contact nearest Hirose account representative.
4. Recommended screw torque values.

[Unit: N'm]

Screw type	Standard torque	Upper tolerance limit
Steel screws	0.142	0.180
Brass screws	0.124	0.168

•Screws : M2 X 0.4

◆ Washing Conditions

This product is a no-wash item, but in the case of washing, please observe the following conditions.

1. Organic Solvent Washing

Solvent	Room temperature washing	Heated washing
IPA (Isopropyl alcohol)	YES	YES
HCFC (Hydrochlorofluorocarbon)	YES	YES

2. Water Type Washing

When using water type cleaning agents (e.g., terpene, and alkali saponifiers), select the cleaning agent based on the documentation issued by the various manufacturers of cleaning agents which describes the effects on metals and resins.

Be careful that parts are not left with moisture remaining on them.

3. Washing Precautions

Residual flux or cleaning agent on the contacts when washing with organic solvents or water type cleaners can give rise to the deterioration of electrical performance. In this regard it is important to check whether a thorough washing has been performed.