

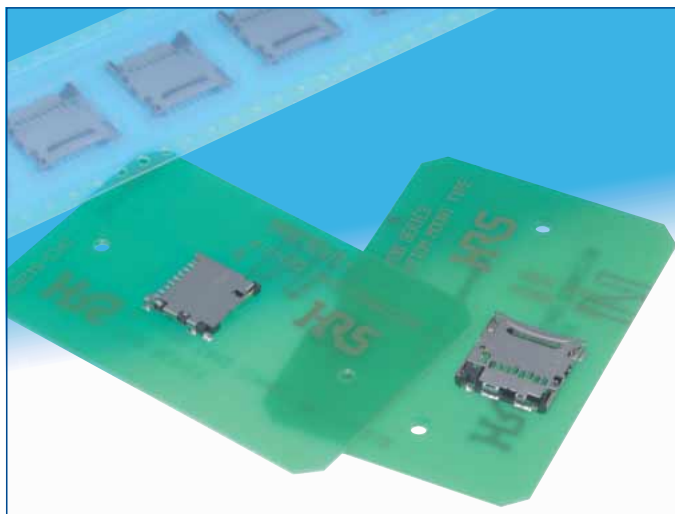

microSD™ Card Connectors

DM3 Series

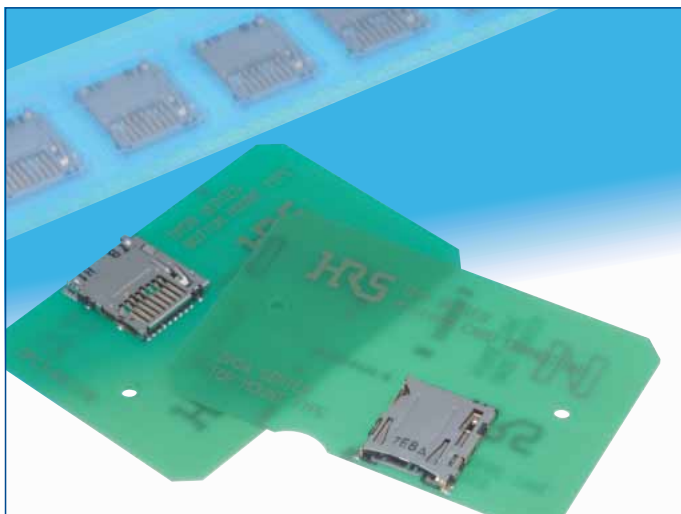

■ Features

◆ Common to the entire Series

1. Extremely small size

Small external dimensions and the above-the-board height make the connectors the smallest on the market.

2. Reverse card insertion protection

Unique card slot design (patent pending) protects the connector from damage when the card is attempted to be inserted in reverse, allowing it to re-inserted correctly.

3. Effective ground and shield configuration

4-connection points of the metal cover to the printed circuit board assures secure connection of the ground circuit and provides EMI protection.

4. Rigid and strong construction

Despite its small size, high-strengths materials used in the connectors produced a strong and rigid structure.

5. Card detection switch

The card detection switch is Normally Open

6. RoHS compliant

All components and materials comply with the requirements of the EU Directive 2002/95/EC

◆ DM3AT and DM3B (Push - Push, with ejection mechanism)

• Card fall-out prevention

Built-in card tray and the unique push insertion-push ejection mechanism (patent pending) prevent accidental card ejection or fall-out.

Despite its small size the connectors will eject the card to a distance of 4.0 mm, allowing easy hold and removal of the card.

• Exposed termination leads

Easy inspection and rework of the solder termination joints.

◆ DM3C (Hinge, Push-Pull, manual, without ejection mechanism)

• Simple and reliable card insertion

Hinged metal cover provides location and guides the card during the insertion / removal. Closing of the cover confirms the electrical and mechanical connection with a tactile click sensation.

• Reliable contact with the card contact pads

Unique contact design and card slide action will clean the contact areas of the card.

• Accessible termination areas

Contact solder terminations may be inspected and reworked.

◆ DM3D (Push -Pull, manual, without ejection mechanism)

• Partial card insertion hold



Card will not fall-out even when it is not fully inserted. Full insertion and electrical / mechanical connection is confirmed with a distinct tactile feel.

• Accessible termination areas

An inner lead system that can be reworked is used in this design. Contact solder terminations may be inspected and reworked.

■ Applications

Mobile phone terminals, digital cameras, PDA's, miniature information terminals and any other portable device requiring use of small size high reliability microSD memory card connectors. etc.

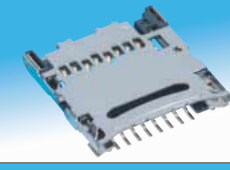
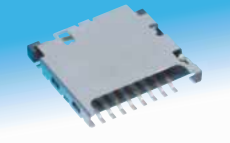
Card insertion-ejection	Series	Image	Page
Push-Push	DM3AT		2~4
	DM3B		5~7
Hinge-manual insertion/ejection	DM3C		8~10
Push-Pull manual insertion/ejection	DM3D		11~13

DM3 Series microSD Card Connectors

Specifications(DM3 Series)

Ratings	Current rating: 0.5A Voltage rating: 125V AC	Operating temperature range: -25°C to +85°C (Note 1) Storage temperature range : -40°C to +85°C (Note 2)	Operating humidity range: RH 95% max. (No condensation)
----------------	---	---	--

Item	Specification	Conditions
1. Insulation resistance	1000 MΩ min. (Initial value)	Measure at 500 V DC
2. Withstanding voltage	No flashover or insulation breakdown	500 V AC / 1 minute
3. Contact resistance	100mΩ max. (Initial value)	1mA
4. Vibration	No electrical discontinuity of 100 ns or longer No damage, cracks or parts dislocation.	Frequency: 10 to 55 Hz, single amplitude of 0.75 mm, 3 directions for 2 hours
5. Humidity	Contact resistance: 40 mΩ max. (change from initial value) Insulation resistance: 100 MΩ min. No damage, cracks or parts dislocation.	96 hours at of 40 ± 2°C, and humidity of 90 to 95%
6. Temperature cycle	Contact resistance: 40 mΩ max. (change from initial value) Insulation resistance: 100 MΩ min. No damage, cracks or parts dislocation.	-55°C → 5 to 35°C → 85°C → 5 to 35°C Times: 30 min. → 5 min. → 30 min. → 5 min. 5 cycles
7. Durability	Contact resistance: 40 mΩ max. (change from initial value)	10,000 cycles, 400 to 600 cycles per hour (DM3AT, DM3B) 5,000 cycles, 400 to 600 cycles per hour (DM3C, DM3D)
8. Resistance to soldering heat	No deformation of components affecting performance.	Reflow : At the recommended temperature profile Manual soldering : 350°C for 3 seconds

Note 1: Includes temperature rise caused by current flow.

Note 2. The term "storage" refers to products stored for long period prior to mounting and use.

Materials and Finishes

DM3AT, DM3B

Part	Material	Finish	Remarks
Insulator	LCP	Color: Black	UL94V-0
Contacts	Copper alloy	Contact area: Gold plated Lead area: Gold plated	_____
Guide cover	Stainless steel (DM3AT) Copper alloy (DM3B)	Lead area: Gold plated	_____
Other components	Stainless steel Piano wire	_____ Nickel plated	_____

DM3C, DM3D

Part	Material	Finish	Remarks
Insulator	LCP	Color: Black	UL94V-0
Contacts	Copper alloy	Contact area: Gold plated Lead area: Gold plated	_____
Guide cover	Stainless steel	Tin plated	_____

Ordering information

DM3 AT – SF – PEJ

① ② ③ ④

① Series name: DM3	③ Termination type : SF Right-angle SMT(Standard) DSF Right-angle SMT(Reverse)
② Connector type : AT Push-Push (ejection mechanism), Top board mounting (Standard) B Push-Push (ejection mechanism), Bottom board mounting (Reverse) C Hinge, Push-Pull (no ejection mechanism), Top board mounting (Standard) D Push-Pull (no ejection mechanism), Top board mounting (Standard) Number of contacts : 8	
	④ Card ejection code : PEJ (Push insert/push eject) None : Manual card insertion/ejection

DM3AT Push-Push (ejection mechanism), Top board mounting (Standard)



Part number	CL No.	RoHS
DM3AT-SF-PEJ	609-0023-2	YES

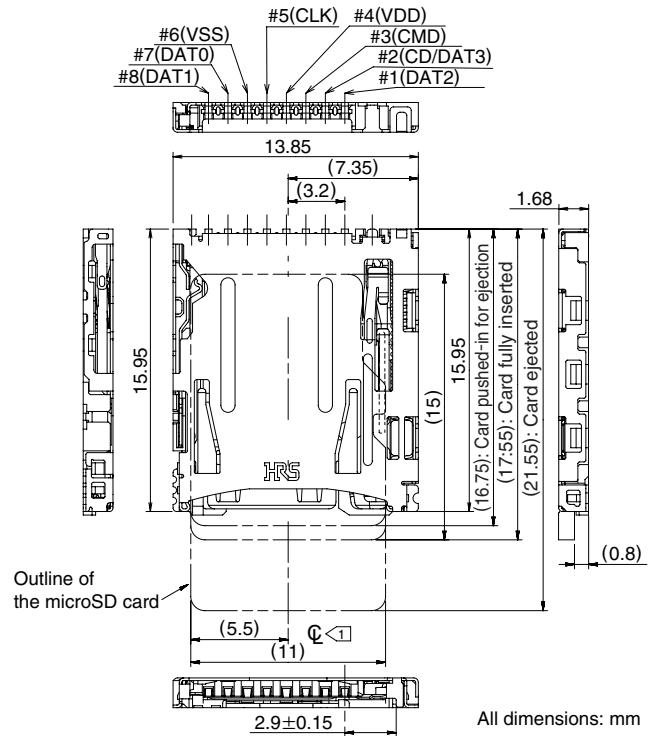

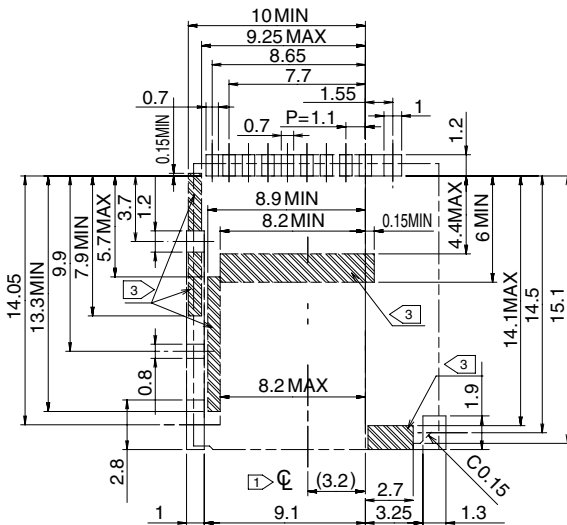

Recommended PCB mounting pattern



Note 1 $\varnothing < 1$ indicates the center line of the microSD card slot.

2

Card detection switch	
Without the card	Card inserted
Open	Closed
 (A) (B)	 (A) (B)

3  No conductive traces.

All dimensions: mm

Example of applications

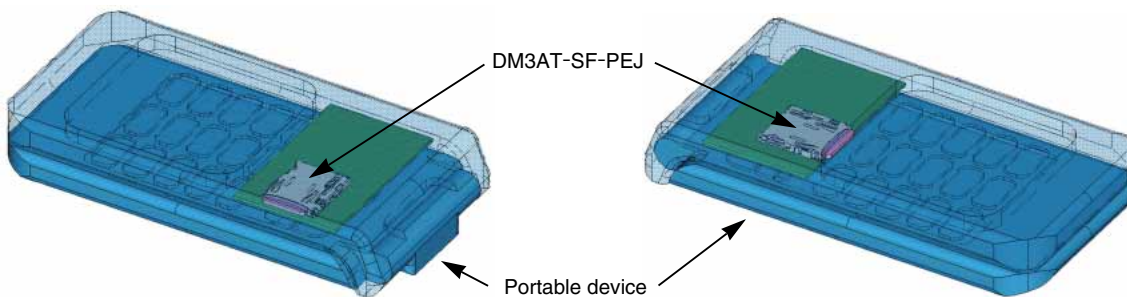

DMS Series microSD Card Connectors

■ Packaging Specifications

- Embossed carrier tape dimensions (1,500 pieces per reel)

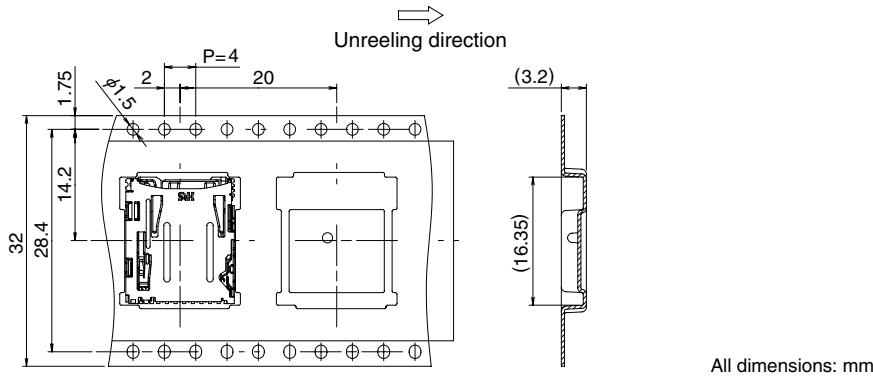

- Reel Dimensions

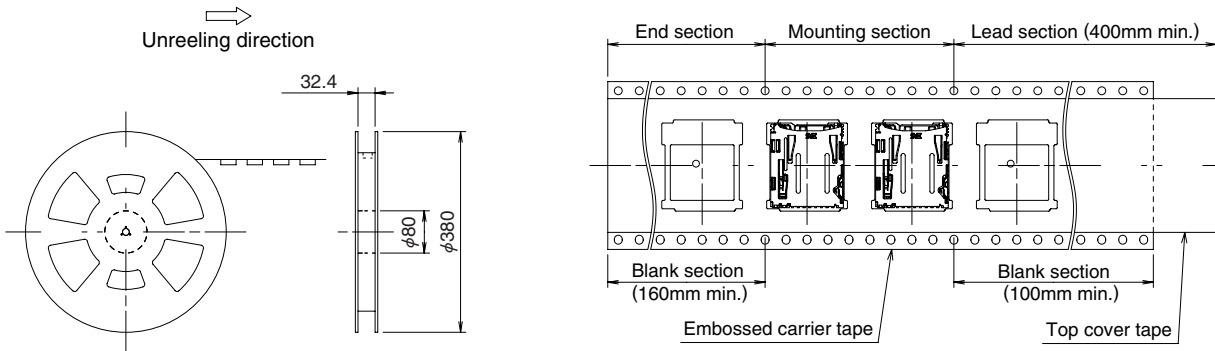

DM3B, Push-Push (ejection mechanism), Bottom board mounting (Reverse)

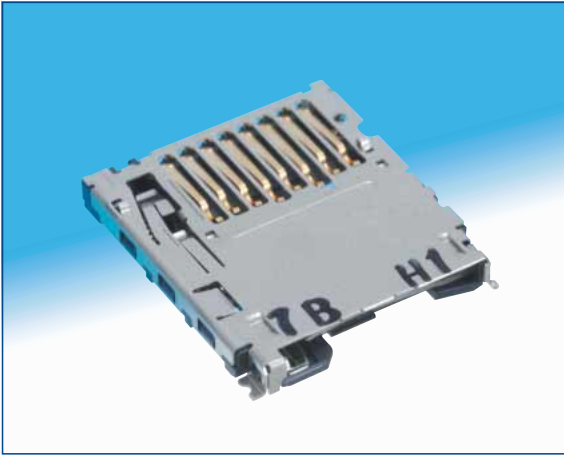

Part number	CL No.	RoHS
DM3B-DSF-PEJ	609-0018-2	YES

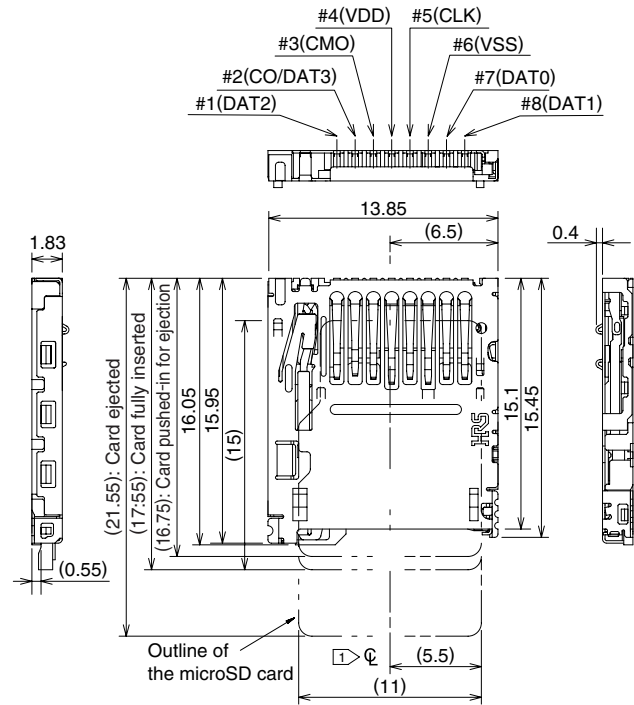

Recommended PCB mounting pattern

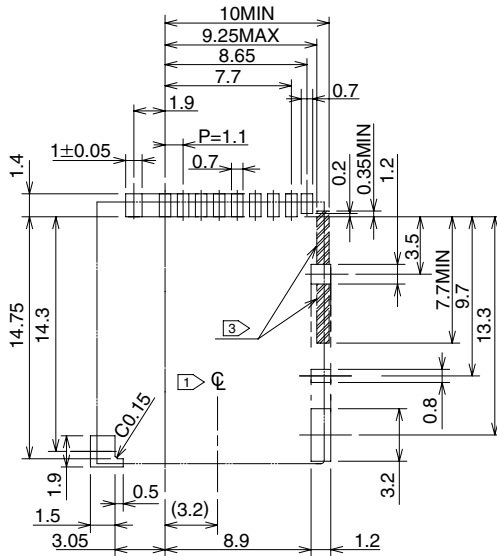

Note 1 ϕ indicates the center line of the microSD card slot.

Card detection switch			
Without the card		Card inserted	
Open	Closed	Open	Closed
(A) (B)	(A) (B)	(A) (B)	(A) (B)

3 No conductive traces.

All dimensions: mm

Example of applications

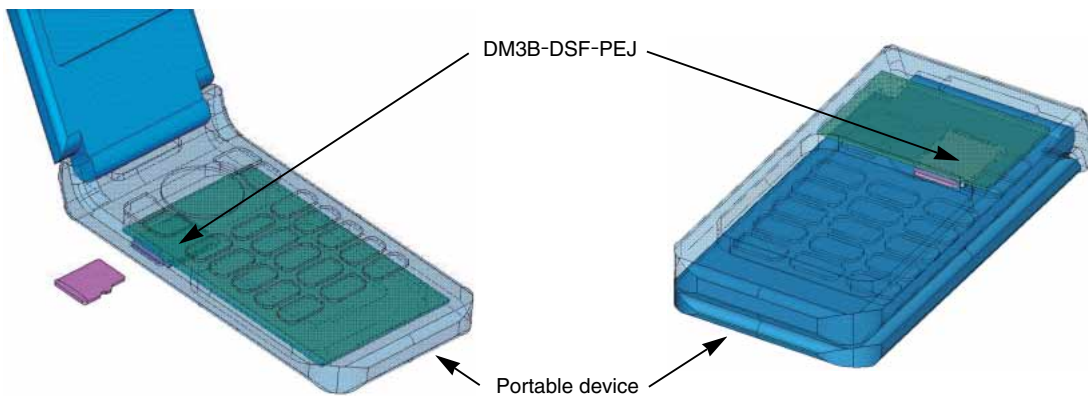

DMS Series microSD Card Connectors

■ Packaging Specifications

- Embossed carrier tape dimensions (1,200pieces per reel)

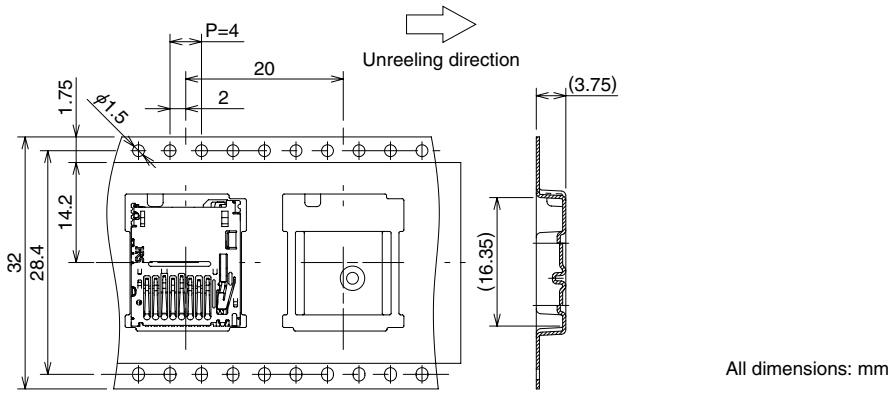

- Reel Dimensions

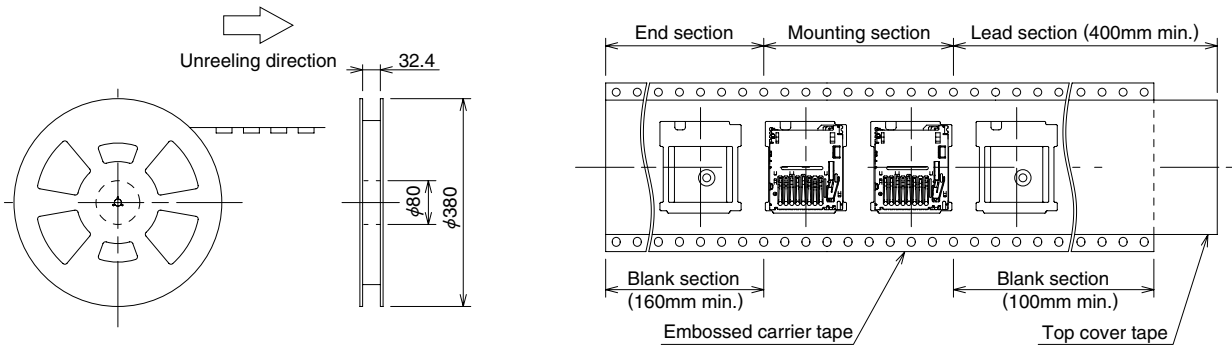

DM3C, Hinge, Push -Pull (no ejection mechanism), Top board mounting (Standard)

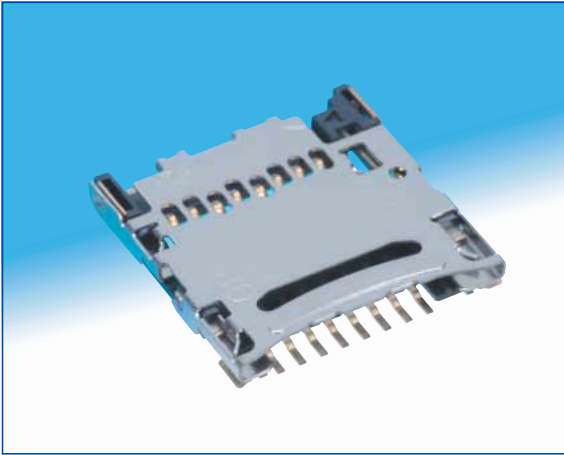

Part number	CL No.	RoHS
DM3C-SF	609-0019-5	YES

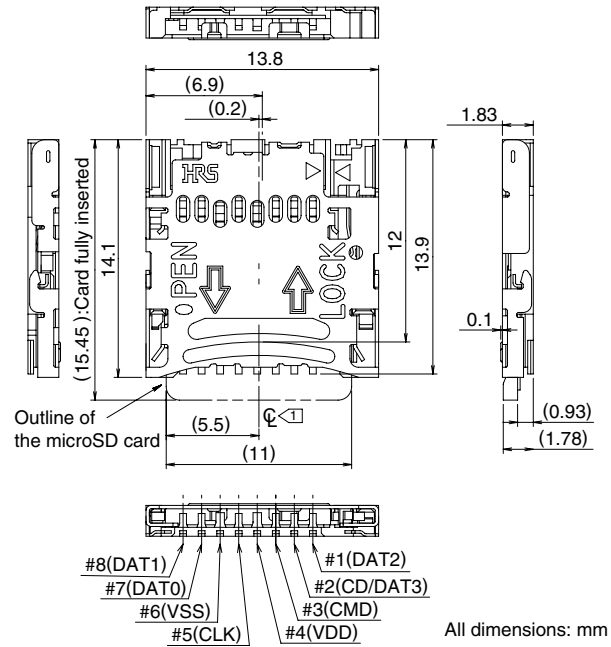

Recommended PCB mounting pattern

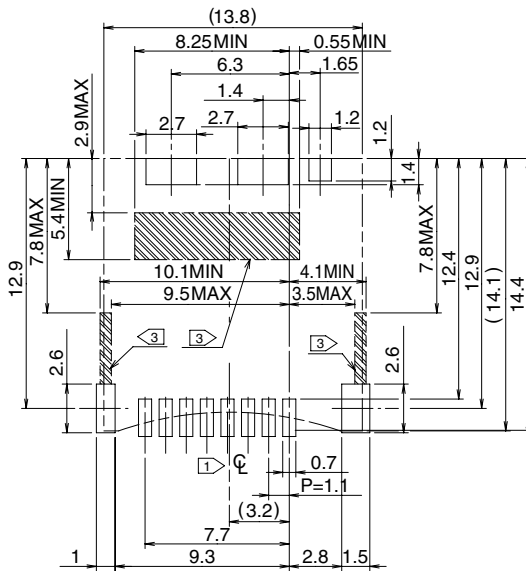

Note 1 Φ indicates the center line of the microSD card slot.

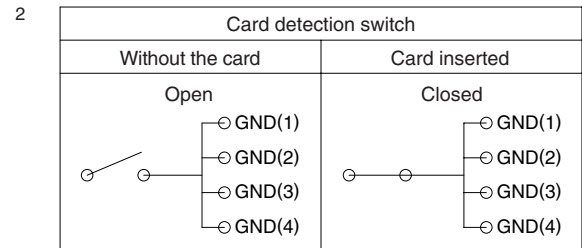

3 No conductive traces.

All dimensions: mm

Example of Use applications

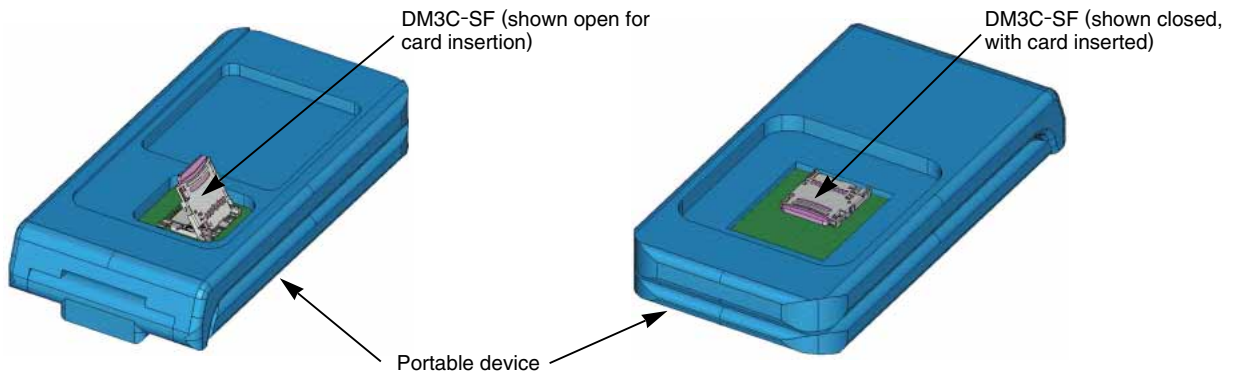

■ Packaging Specifications

- Embossed carrier tape dimensions (1,300pieces per reel)

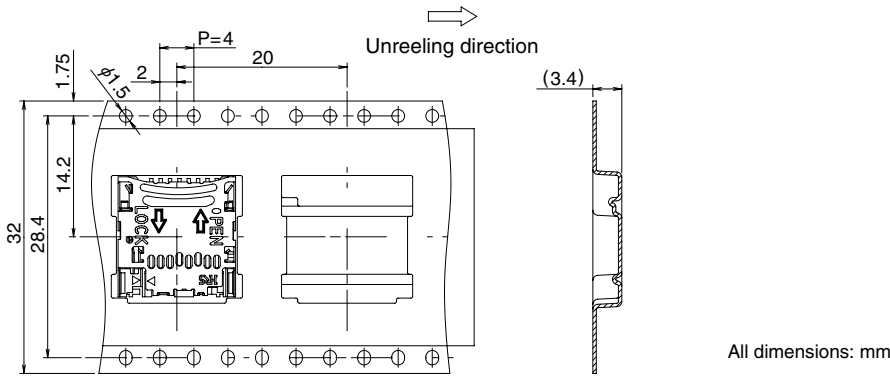

- Reel Dimensions

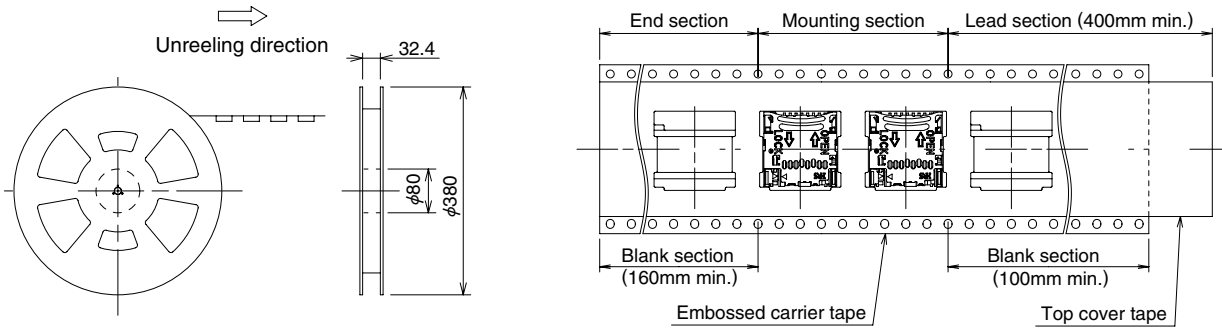

DM3D, Push-Pull (no ejection mechanism), Top board mounting (Standard)

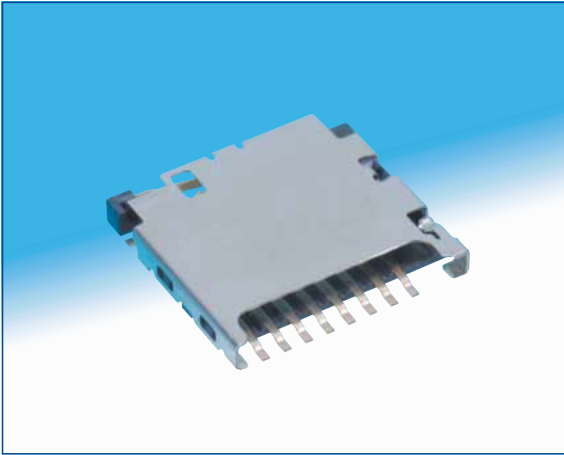

Part number	CL No.	RoHS
DM3D-SF	609-0025-8	YES

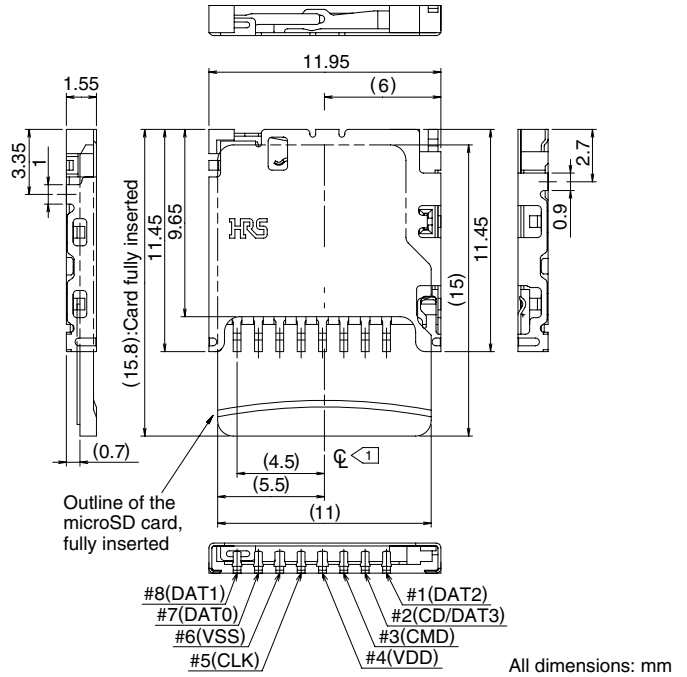

Recommended PCB mounting pattern

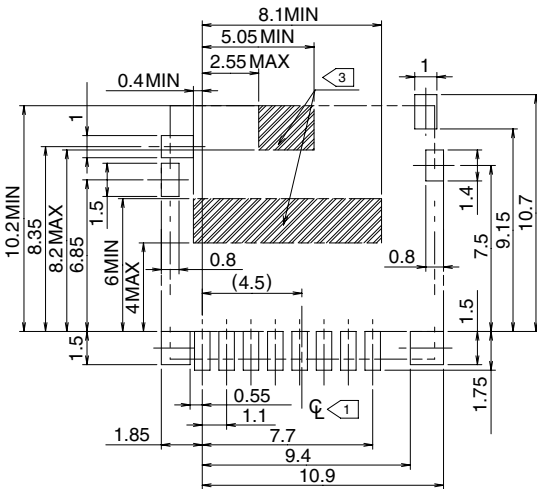

Note 1 ϕ indicates the center line of the microSD card slot.

2

Card detection switch	
Without the card	Card inserted
Open	Closed
(A) (B)	(A) (B)

3 No conductive traces.

All dimensions: mm

Example of applications

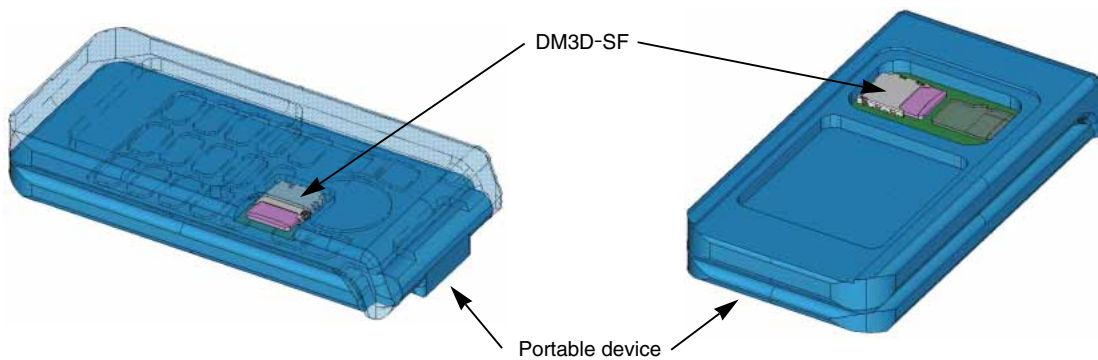

■ Packaging Specifications

- Embossed carrier tape dimensions (2,000pieces per reel)

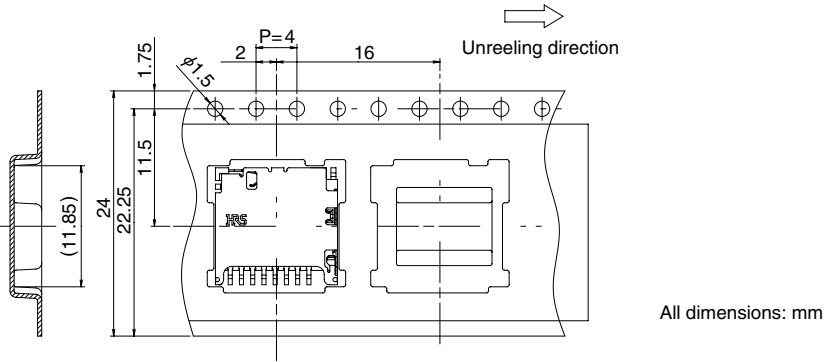

- Reel Dimensions

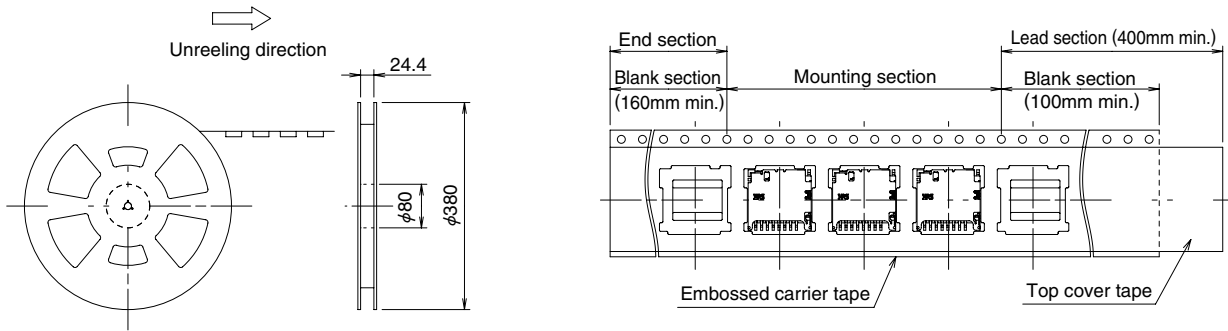

Recommended temperature profile

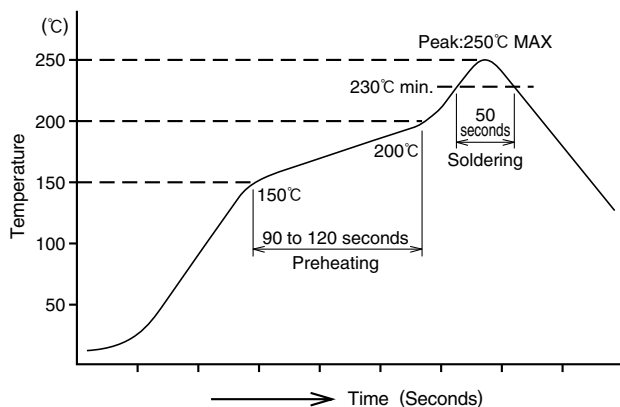

HRS test condition

Solder method :Reflow, IR/hot air
 Environment :Room air
 Solder composition :Paste, 96.5%Sn/3.0%Ag/0.5%Cu
 (Senju Metal Industry, Co., Ltd.'s
 Part Number:M705-GRN360-K2-V)
 Test board :Glass epoxy 60mm×100mm×1.0mm thick
 Metal mask :0.12mm thick

The temperature profiles shown are based on the above conditions.

In individual applications the actual temperature may vary, depending on solder paste type, volume / thickness and board size / thickness. Consult your solder paste and equipment manufacturer for specific recommendations.

Precautions

1. Do not immerse or clean the entire connector with cleaning solutions as this may affect proper operation of the ejection mechanism and electrical performance of the connector
2. Do not apply excessive force to the connector when handling or after installation on the PC board.
3. The connectors will reliably connect and operate with the correctly inserted microSD™ cards. Follow the correct insertion / ejection procedure for the specific connector in use. Attempts of incorrect insertion of the card may cause damage to the connector or the card.
4. The connector must be correctly mounted on the PC board before the card can be inserted. Do not insert the card in the un-mounted connector.
5. Mounting on the Flexible Printed Circuit (FPC)
 To assure correct performance it is recommended that a flat reinforcement plate 0.3 mm min. thick be used under the FPC.
6. Small visible residual manufacturing fluids or tooling marks do not affect connector's performance.
7. Repeated insertions and removal of the cards may leave some marks on the card itself. This will have no effect on the connector performance.

Refer to applicable Operation Manual listed below for additional precautions.

Series	Operation Manual Number
DM3AT Series	ETAD-F0345
DM3B Series	ETAD-F0324
DM3C Series	ETAD-F0335
DM3D Series	ETAD-F0353