

Customer Information Sheet

DRAWING No.: M52-515XX45

SHEET 2 OF 2

IF IN DOUBT - ASK

(C)

NOT TO SCALE

THIRD ANGLE PROJECTION

ALL DIMENSIONS IN mm

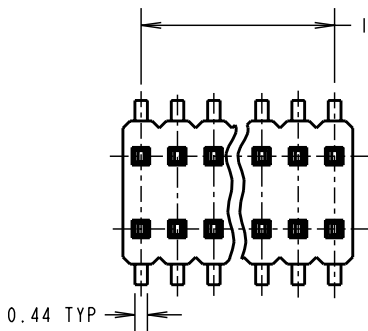

1.27 x No. OF PITCHES PER ROW

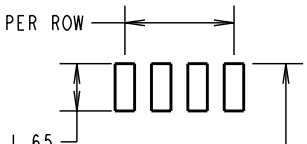

RECOMMENDED PCB LAYOUT
(PCB TOLERANCE ±0.05)

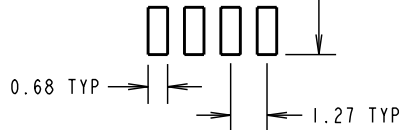

SPECIFICATIONS:

MATERIAL:
 MOULDING = NYLON 6T UL94V-0, BLACK
 CONTACT = PHOSPHOR BRONZE
FINISH:
 CONTACT = GOLD
ELECTRICAL:
 CURRENT RATING = 1A
 VOLTAGE PROOF = 500V AC/DC
 CONTACT RESISTANCE = 20 MILLIOHMS MAX
 INSULATION RESISTANCE = 1,000 MEGOHMS MIN
ENVIRONMENTAL:
 OPERATING TEMPERATURE = -40°C TO +105°C
PACKING:
 TUBE

NOTES:

1. ALL TOLERANCES ARE ±0.20 UNLESS OTHERWISE STATED.

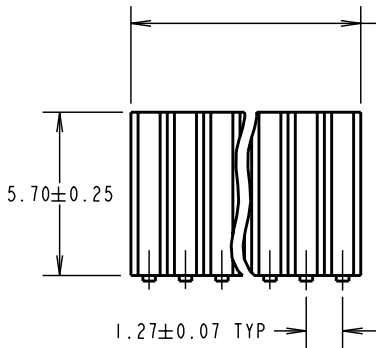

CONTACT POINT
1.40 ±0.10

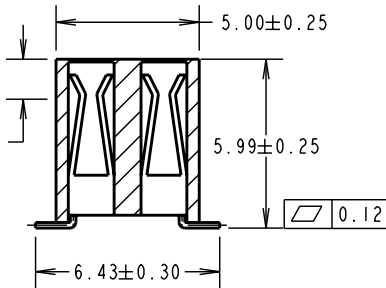

ORDER CODE:

M52-515XX45

No. OF WAYS PER ROW
03 TO 50

FINISH: GOLD

CP	7	10.12.09	10603
NAME	ISS.	DATE	C/NOTE
APPROVED: C. PENROSE			
CHECKED: R. ADDE			
DRAWN: J. ENRIGHT			
CUSTOMER REF.:			
ASSEMBLY DRG:			

HARWIN

HARWIN USA
 TEL: 603 893 5376
 FAX: 603 893 5396
 mis@harwin.com

HARWIN Europe (UK)
 TEL: 023 9231 4545
 FAX: 023 9231 4590
 mis@harwin.co.uk

HARWIN Asia
 TEL: +65 6 779 4909
 FAX: +65 6 779 3868
 mis@harwin.com.sg

THIS DRAWING AND ANY INFORMATION OR DESCRIPTIVE MATTER SET OUT HEREON ARE CONFIDENTIAL AND COPYRIGHT PROPERTY OF THE HARWIN GROUP AND MUST NOT BE DISCLOSED, LOANED, COPIED OR USED FOR MANUFACTURING, TENDERING OR FOR ANY OTHER PURPOSE WITHOUT THEIR WRITTEN PERMISSION.

TOLERANCES
~~X = ±1mm~~
~~X.X = ±0.25mm~~
~~X.XX = ±0.10mm~~
~~X.XXX = ±0.01mm~~
 ANGLES = ±5°
 UNLESS STATED

MATERIAL:

SEE ABOVE

FINISH: SEE ABOVE

S/AREA: mm²

TITLE:

1.27mm PITCH DIL
 VERTICAL SMT SOCKET ASSY

DRAWING NUMBER:

M52-515XX45

SHT
 2 OF 2