

**NOTE**

All numerical values are in metric units [with U.S. customary units in brackets]. Dimensions are in millimeters. Unless otherwise specified, dimensions have a tolerance of  $\pm 0.13$  and angles have a tolerance of  $\pm 2^\circ$ . Figures and illustrations are for identification only and are not drawn to scale.

**1. INTRODUCTION**

This specification covers the requirements for application of High Speed Serial Data Connector 2 (HSSDC2). The INFINIBAND standard and Fibre Channel standard 7-position receptacle assemblies are available in Surface Mount Technology (SMT) configurations only. The 14-position (Dual Row) versions have one row of 7 SMT contacts and one row of 7 thru hole contacts. The contacts are gold plated on 1.27 mm centerlines. The receptacle connectors will mate with HSSDC2 cable plug connectors which are available from Tyco Electronics as component kits or sold pre-assembled onto cable assemblies. The INFINIBAND standard and Fibre Channel standard system is a 7-position connector with 4 high-speed lines and 3 grounds.

When corresponding with Tyco Electronics personnel, use the terminology provided on this specification to help facilitate your inquiry for information. Basic terms and features of components are provided in Figure 1.

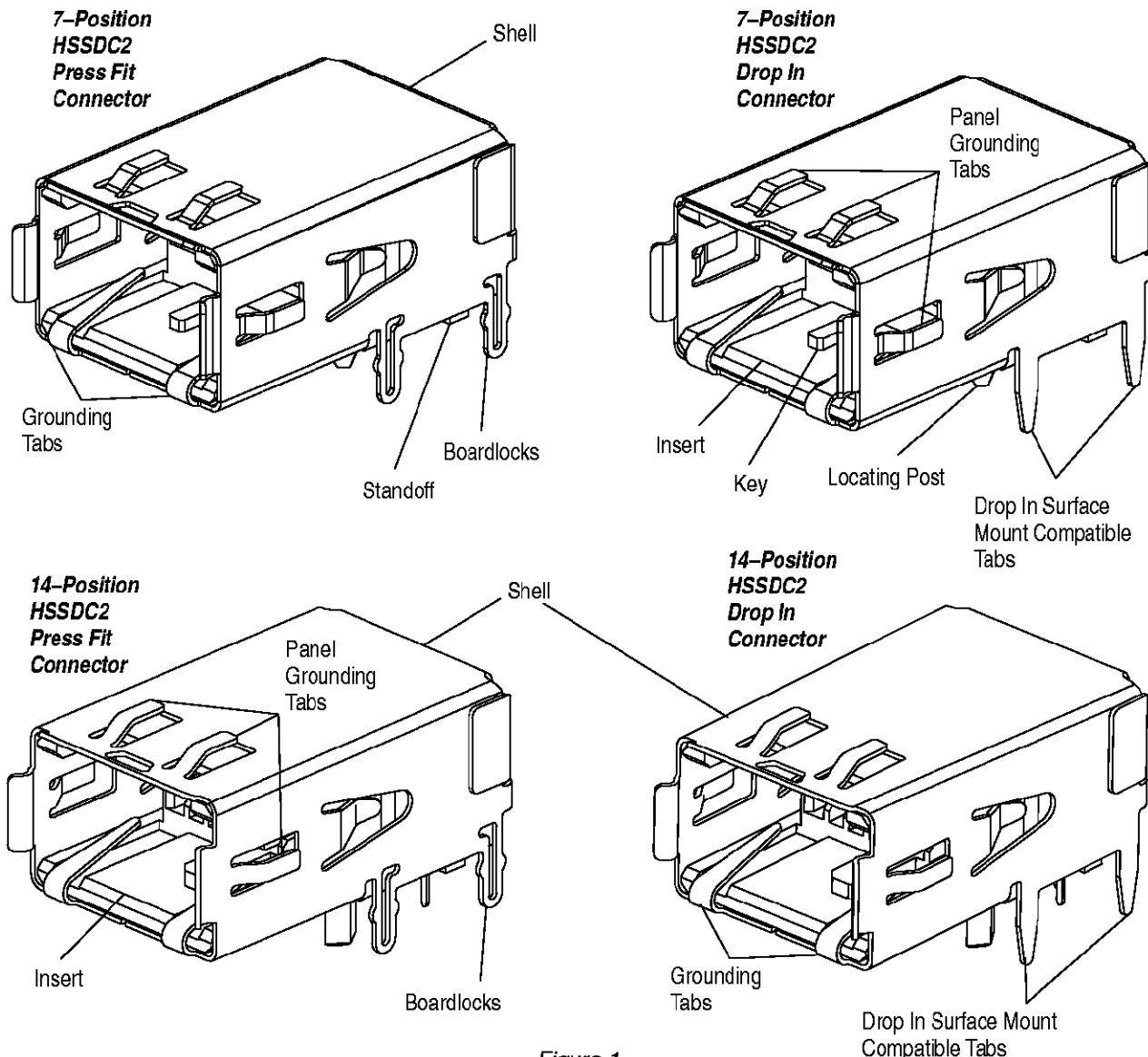

Figure 1

## 2. REFERENCE MATERIAL

### 2.1. Revision Summary

Per EC 0990–1742–02

- Updated document to corporate requirements
- Removed plug connector from document and placed on new application specification 114–13097
- Added new and/or changed illustrations in Figures 1, 2, 4, 6, 9, 11, 14 and related callouts
- Added new text to Introduction, Paragraphs 2.4, 3.7.b, and 3.13
- Added new Paragraph 3.3 and renumbered

### 2.2. Customer Assistance

Reference Part Number 1364532 and Product Code E608 are representative numbers of High Speed Serial Data Connector 2 (HSSDC2). Use of these numbers will identify the product line and expedite your inquiries through a service network established to help you obtain product information. Such information can be obtained through a local Tyco Electronics Representative (Field Sales Engineer, Field Applications Engineer, etc) or, after purchase, by calling the Tooling Assistance Center or the AMP FAX/Product Information Center number at the bottom of page 1.

### 2.3. Drawings

Customer Drawings for the connectors are available from the service network. The information contained in Customer Drawings takes priority if there is a conflict with this specification or with any technical documentation supplied by Tyco Electronics.

### 2.4. Specifications

Product Specifications 108–1965 (7–position) and 108–2065 (14–position), provide product performance requirements and test information. Test Specification 109–11 provides information pertaining to the solderability. Workmanship Specification 101–21 provides information on solder fillets of surface mount products. Application Specification 114–13097 provides HSSDC2 plug assembly requirements.

### 2.5. Manuals

Manual 402–40 is available upon request and can be used as a guide in soldering. This manual provides information on various flux types and characteristics along with the commercial designation and flux removal procedures. A checklist is included in the manual as a guide for information on soldering problems.

### 2.6. Instructional Material

Instruction Sheet 408–6927 provides Design Recommendations for Printed Circuit (PC) Board Support Fixtures.

## 3. REQUIREMENTS

### 3.1. Safety

Do not stack product packages so high that the shipping containers buckle or deform.

### 3.2. Storage

#### A. Ultraviolet Light

Prolonged exposure to ultraviolet light may deteriorate the chemical composition used in the connectors.

#### B. Shelf Life

To prevent damage to the connectors, they should remain in the shipping containers until ready for installation. Also, to prevent possible storage contamination, these products should be used on a first in, first out basis.

#### C. Chemical Exposure

Do not store the connectors near any chemical listed below as they may cause stress corrosion cracks in the contacts.

Alkalies	Ammonia	Citrates	Phosphates	Citrates	Sulfur Compounds
Amines	Carbonates	Nitrites	Sulfur Nitrites	Tartrates	

**3.3. Materials**

The contacts are phosphor bronze with the mating end plated with gold over nickel. The contact tines are plated with tin-lead. The connector shell is made of phosphor bronze.

**3.4. Mating Keys**

When selecting an HSSDC2 receptacle assembly, care must be taken to make sure that the key matches the key of the plug assembly. See Figure 1. HSSDC2 receptacles are available with INFINIBAND standard keying or Fibre Channel standard keying as well as other optional key configurations. For example, these keys prevent the mating of an INFINIBAND standard keyed plug to a Fibre Channel standard keyed receptacle.

**3.5. Mating Dimension**

The mating dimension in Figure 2 is required to ensure full mating of the connectors. When the plug and receptacle assembly are bottomed, there will be an audible and tactile click to ensure full mating. These dimensions must be considered when determining panel thickness or pc board applications.

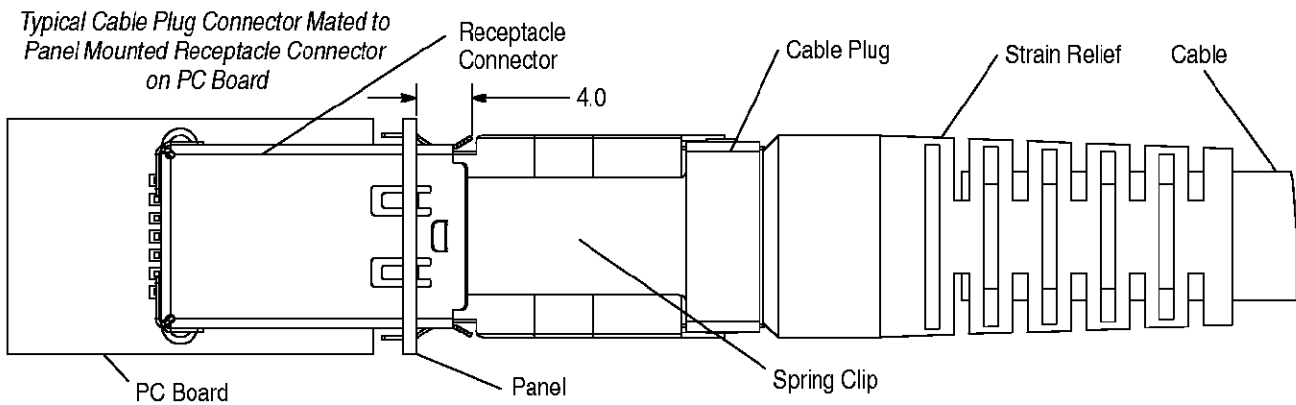

Figure 2

**3.6. Shielding**

These connectors feature tin plated shells which provide continuity for Electro-Magnetic Compatibility (EMC) applications. When mated with corresponding metal shell connectors, shielding and grounding continuity are obtained.

**3.7. Panel Mounting**

This connector may be panel mounted to ensure proper location of the mating interface and to ensure EMC performance. The connectors must be mounted to the rear of the panel only. See Figure 3 for panel cutout dimensions.

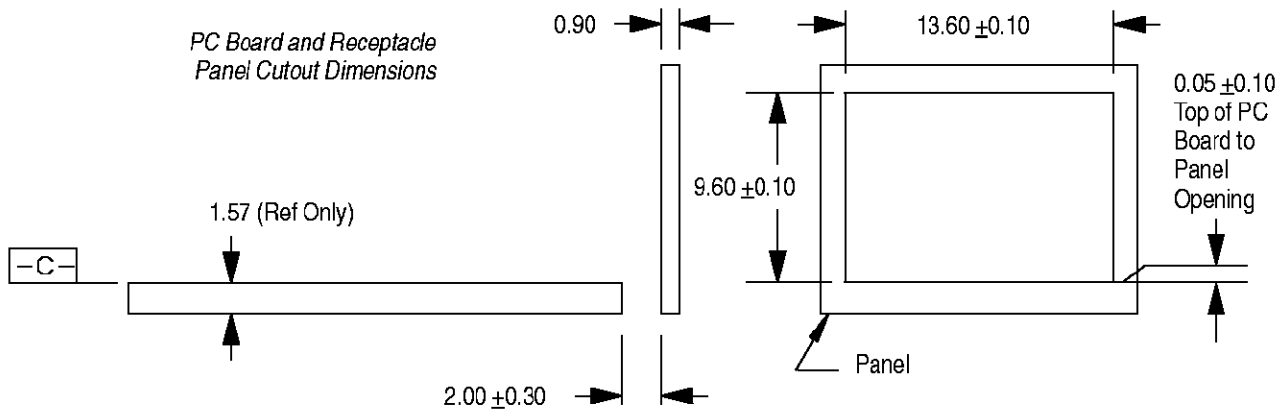

Figure 3

### 3.8. PC Board

#### A. Tolerances

1. Maximum allowable bow of the pc board will be 0.13.
2. Coplanarity of the plated pads on the pc board will be 0.03. See Figure 10.
3. If a solder mask is used, it must allow full clearance around the pads as defined in Figure 4.

#### B. Material and Thickness

The pc board material must be glass epoxy (FR-4 or G-10). The minimum pc board thickness must be 1.57 nominal for 7-position receptacles. For 14-position receptacles, pc board thickness must be specified based upon the process used to solder the thru hole contacts.

#### NOTE

Contact the Product Information Center at the number listed at the bottom of page 1 for suitability of other pc board materials and thicknesses.

#### C. Pads

The pc board pads must be plated and solderable in accordance with Tyco Electronics Test Specification 109-11-2. Additional information on solderability and soldering variables can be found in Manual 402-40.

#### D. Layout

Recommended pc board patterns and dimensions, as well as tolerance, are provided in Figure 4. The contact pads, standoffs, and boardlocks must be precisely located to ensure proper placement and optimum performance of the connector. The layout shows the top (connector) side of the pc board. Datums and basic dimensions are established by the customer.

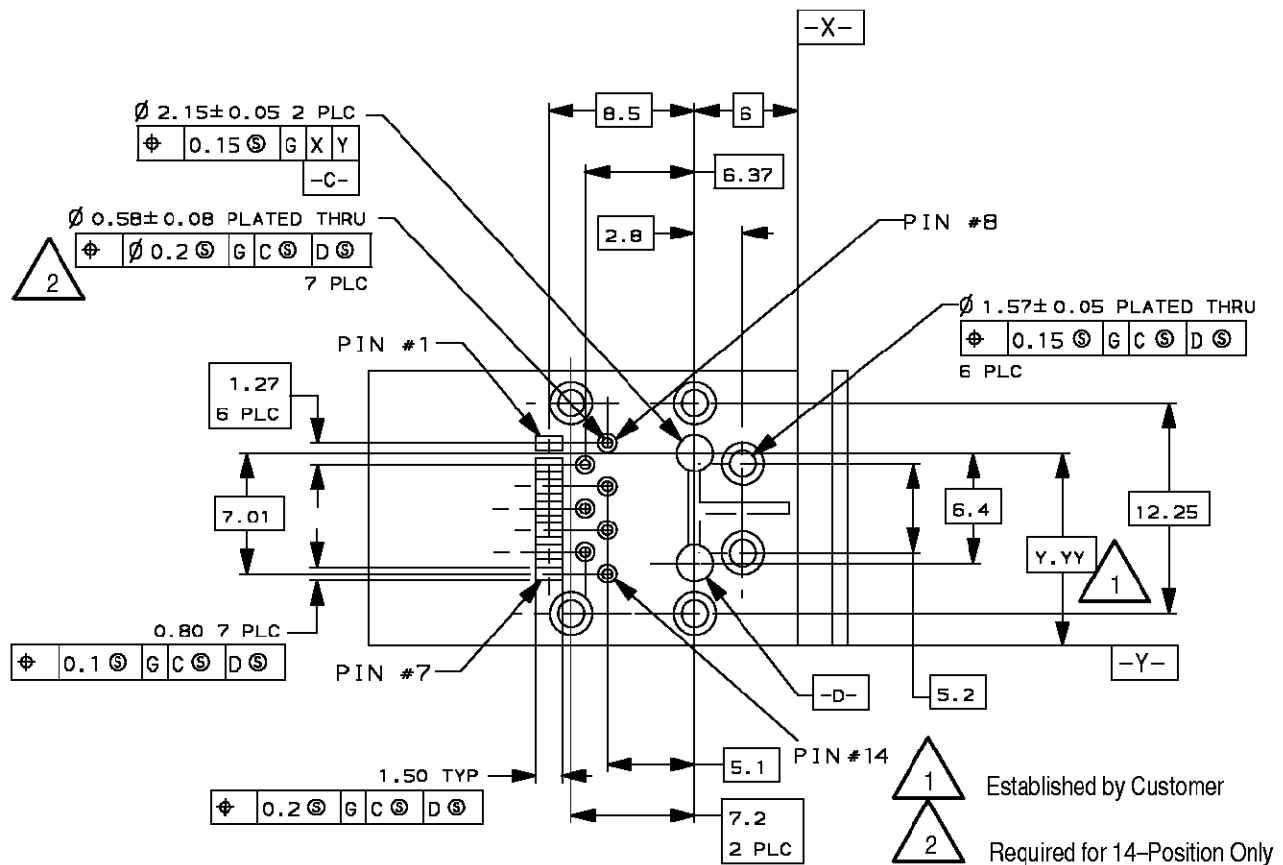

Figure 4

#### E. PC Board Plated Thru Holes

The pc board holes (6 plc) must be drilled and plated as shown in Figure 5. The boardlocks have gripping shoulders that pass through the pc board and are locked into position when the connector is seated on the pc board.

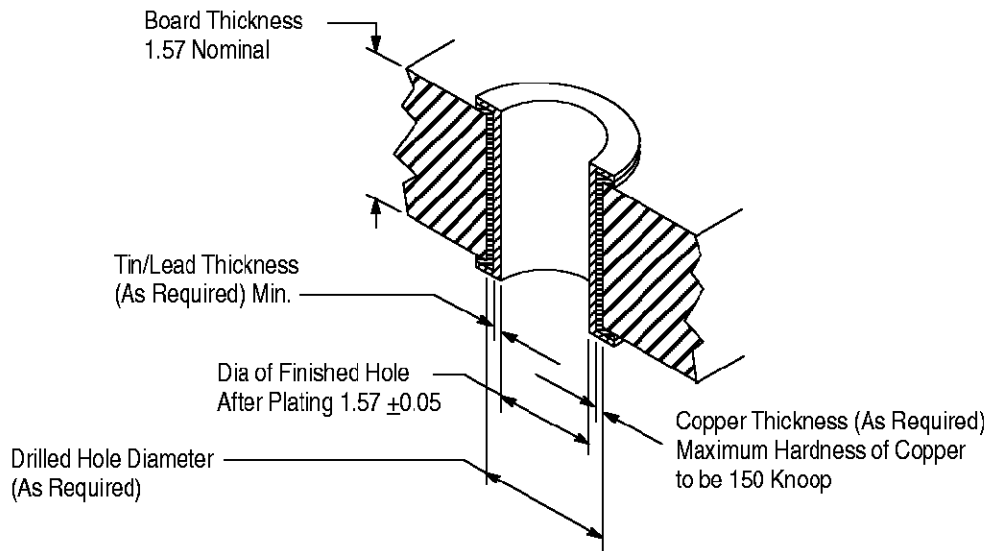

Figure 5

### 3.9. Solder Paste Characteristics

#### A. Composition

1. Alloy type shall be 63 Sn/37 Pb, 60 Sn/40 Pb, or 62 Sn/36 Pb/2 Ag
2. Flux incorporated in the paste shall be rosin, mildly active (RMA) type.
3. Paste will be 80% solids by volume.

#### B. Volume Requirements

Recommended solder paste volume on each contact pad before curing is  $(0.20 \times 10^{-2})^3$ . Recommended solder paste volume on each press fit tail or drop in tail plated through-hole before curing is  $(0.75 \times 10^{-2})^3$ . An outgassing factor (usually measured to be around 50%) will reduce the paste volume after curing. Since solder paste can be deposited with a stencil or screen, the following calculations should serve as a guideline in varying deposition parameters.

**NOTE**

*Solder volume may vary depending on solder paste composition.*

**CAUTION**

*Using paste volume in excess of those recommended could cause excessive wicking of reflowed solder onto the contact solder lead resulting in a weak solder joint.*

#### 1. Stencils

- Let:  $V_1$  = Solder paste volume before curing  
 $a$  = Aperture dimension corresponding to pad width  
 $b$  = Aperture dimension corresponding to pad length  
 $T_p$  = Thickness of stencil (or deposited solder paste)

Stencil aperture will be determined by the thickness of the stencil being used. Generally, the thinner stencils will have a larger aperture to maintain a given volume of solder paste. Solder deposition should be within the pad area of the contact tines. Typical horizontal and vertical aperture openings are shown in Figure 6. If the aperture dimensions on the stencil are the same as the nominal pad dimensions shown in Figure 4, stencil thickness can be calculated with the following relation:

$$T_p = V_1 / (a \times b)$$

$$T_p = 0.75^3 / (1.25 \times 4.0)$$

$$T_p = 0.15^3$$

Varying aperture dimensions will change the required stencil thickness needed to deposit the recommended solder paste volume.

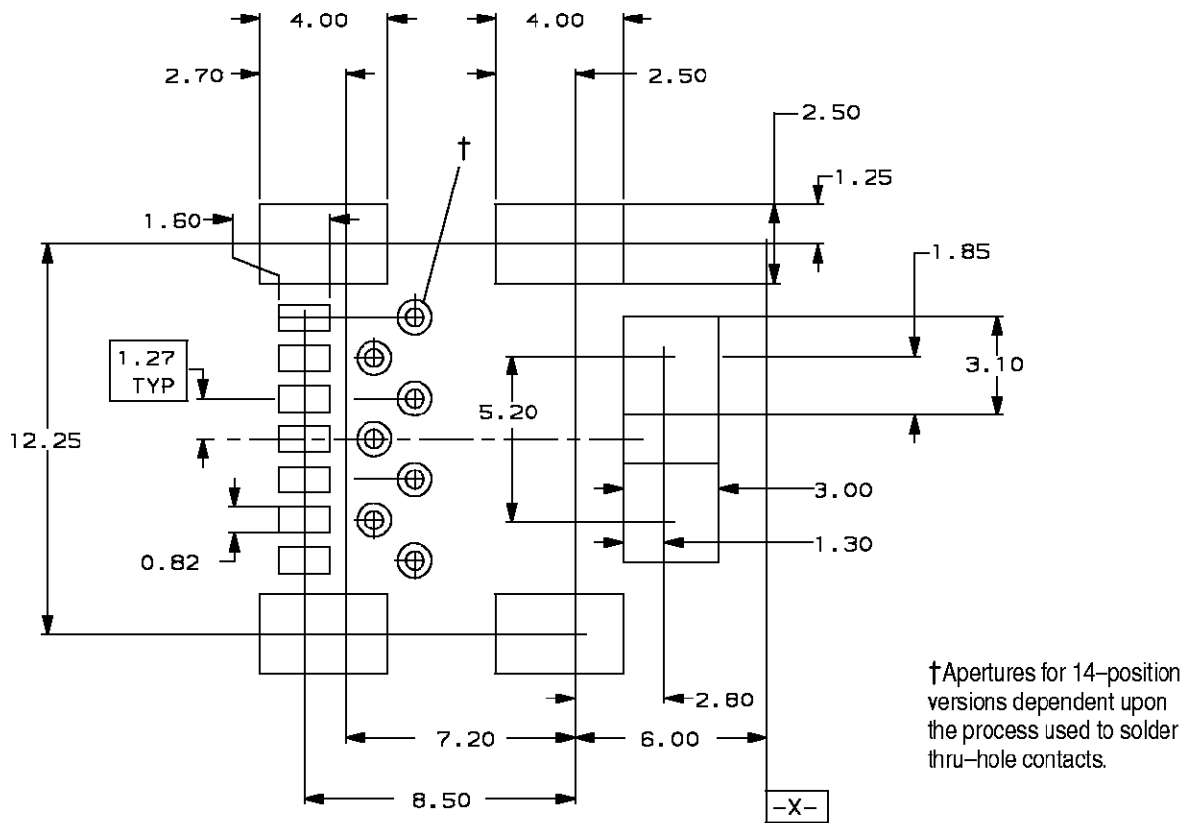

Figure 6

## 2. Screens

- Let:  $T_e$  = Screen emulsion thickness  
 $T_w$  = Screen weave thickness  
 $A_o$  = Decimal equivalent of percent open area  
 $T_p$  = Thickness of deposited solder paste

Weave thickness and percent open area are dependent on the mesh count of the solder screen. For example, an 80-mesh screen has a 49.5% open area and nominal weave thickness of 0.20. The amount of paste deposited through a solder screen is dependent on aperture dimensions, the wire mesh, and applied emulsion.

For an 80-mesh screen with the same aperture dimensions as used in the stencil example above, the emulsion can be calculated by:

$$T_e = T_p - (T_w \times A_o) = 0.20 - (0.20 \times 12.57) = 0.10$$

Varying aperture dimensions and mesh count will change the required emulsion thickness needed to deposit the recommended solder paste volume.

### NOTE

Using paste volume in excess of those recommended could result in excessive wicking of reflowed solder up the solder lead, resulting in reduction of compliance and potential solder joint failure.

Use recommended vendor specifications for paste processing. Additional information on soldering processes and variables can be found in Manual 402-40.

## 3. Mask

If a mask is used, it must allow full clearance around the pads as defined in the pc board layout. Exposed traces could cause bridging and create a short, or wick solder away from the contact solder leads, producing a weak solder joint.

### CAUTION

Since the connector housing may rest on top of the solder mask, an excessively high mask will allow too much space between the lead and pad for a good solder joint. A solder joint under these conditions would be weak, and would not provide long term performance for the connector.

### 3.10. Soldering

#### A. Process

The connectors should be soldered using vapor phase, non-focused infrared (IR) reflow, wave, or equivalent soldering technique. For suitability of other techniques, contact Product Information Center at the number at the bottom of page 1. The temperature and time to which the connector can be subjected is specified in Figure 7.

SOLDERING PROCESS	TEMPERATURE (Max)	TIME (Max)
Vapor Phase	215°C [419°F]	5 Minutes
Infrared Reflow (IR)	230°C [446°F]	5 Minutes
Wave	260°C [500°F]	5 Seconds

Figure 7

#### B. Cleaning

Fluxes, residues, and activators must be removed. Cleaning procedures depend on the type of flux used on the solder line. The following is a list of common cleaning solvents that will not affect these connectors for the time and temperature specified. See Figure 8.

**CAUTION**

*Excessive temperature may cause housing degradation or plating deterioration.*

CLEANER		TIME (Minutes)	TEMPERATURES (Maximum)	
NAME	TYPE		CELSIUS	FAHRENHEIT
ALPHA 2110	Aqueous	1	132	270
BIOACT EC-7	Solvent	5	100	212
Butyl CARBITOL	Solvent	1	Room Ambience	
Isopropyl Alcohol	Solvent	5	100	212
KESTER 5778	Aqueous	5	100	212
KESTER 5779	Aqueous	5	100	212
LONCOTERGE 520	Aqueous	5	100	212
LONCOTERGE 530	Aqueous	5	100	212
Terpene Solvent	Solvent	5	100	212

Figure 8

**DANGER**

*Consideration must be given to toxicity and safety requirements recommended on the Material Safety Data Sheet furnished by the solvent manufacturer.*

**NOTE**

*If you have a particular solvent that is not listed, consult a Tyco Electronics Representative before using it on these connectors.*

#### C. Drying

When drying cleaned assemblies and pc boards, make certain that temperature limitations are not exceeded: -55° to 105°C [-67° to 221°F]. Excessive temperatures may cause housing degradation.

### 3.11. Connector Placement

**CAUTION**

*Connectors should be handled only by the housing to avoid deformation, contamination, or damage to the contact solder tines.*

#### A. Seating

The force required to seat the connector is minimal. Apply only that force necessary to seat the connector boardlocks into the pc board. The connector standoffs must be seated on the pc board not exceeding the dimension shown in Figure 9.

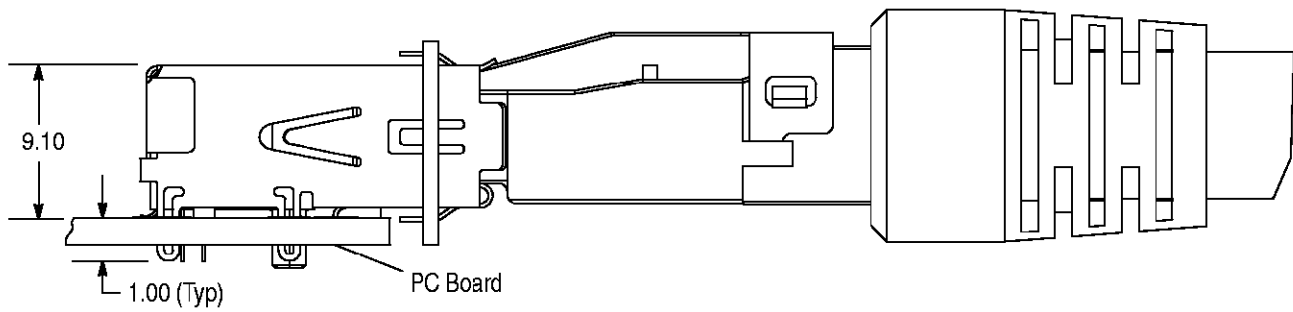

Figure 9

**B. Coplanarity**

Optimally, the contact solder tines should be centered on the pc board circuit pads. However, slight misalignment is permissible as shown in Figure 10.

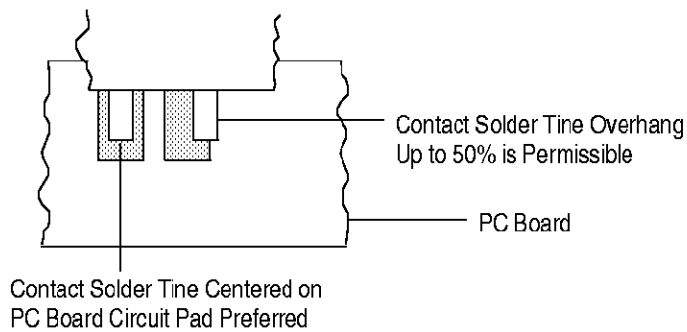

Figure 10

**3.12. Checking Installed Connector**

All solder joints should conform to those specified in Workmanship Specification 101-21 and all other requirements specified in this document.

1. Solder must have 95% minimum solder coverage over the pc board pad. See Figure 11.
2. The connector must be firmly attached to the pc board; there shall be no evidence of connector movement.
3. If using application tooling such as robotics, there shall be no evidence of any damage to the connector.

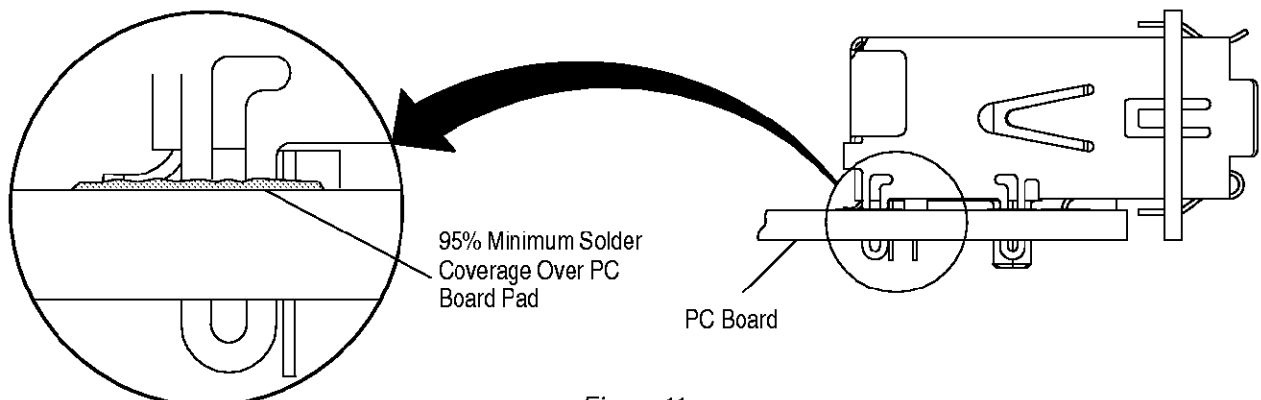

Figure 11



**3.13. Connector Spacing**

Care must be used to avoid interference between adjacent connectors and other components. The information provided in Figure 12 is to ensure proper mating.

**NOTE** *The information provided is for manual placement of connectors. If robotic equipment is used, other space allowances will be required for the grippers.*

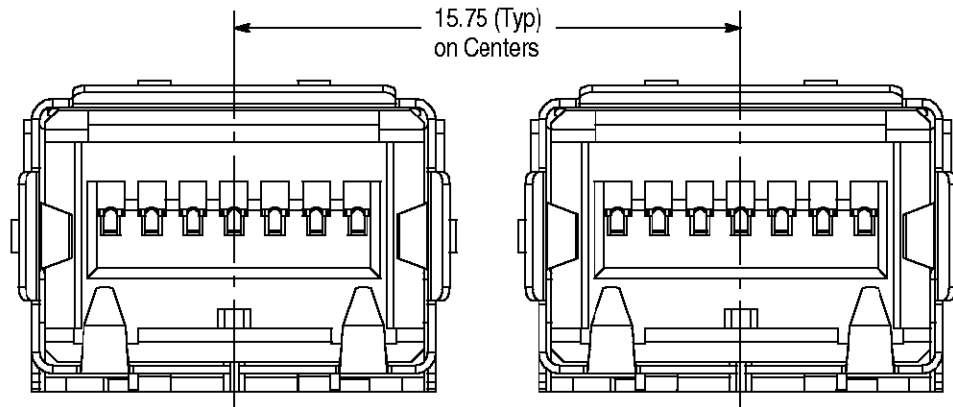

Figure 12

**3.14. Unmating of Connectors**

To unmate the plug and receptacle connector assembly, depress the spring clip on top of the plug and pull the plug assembly straight out of the receptacle assembly.

**3.15. Repair/Removal**

Damaged pc board connectors must be replaced by removing them from the pc board by standard de-soldering methods. Damaged plug connectors must be cut from the cable, the cable must be re-stripped, and a new connector applied.

**4. QUALIFICATIONS**

High Speed Serial Data Connector 2 (HSSDC2) is Recognized by Underwriters Laboratories Inc. (UL) under File Number E81956, which also Certifies this product for CSA International.

**5. TOOLING**

No tooling is required for manual placement of the connectors. For machine placement, a pc board support must be used to prevent bowing of the pc board during placement of the connectors. The robotic equipment must have a true position accuracy tolerance to properly locate the connector. This includes gripper and fixture tolerances as well as equipment repeatability. It must use the connector datum surfaces detailed on the customer drawing to ensure reliable placement. See Figure 13.

**NOTE** *Modified designs and additional tooling concepts may be available to meet other application requirements. For additional information, contact one of the service groups at the bottom of page 1.*

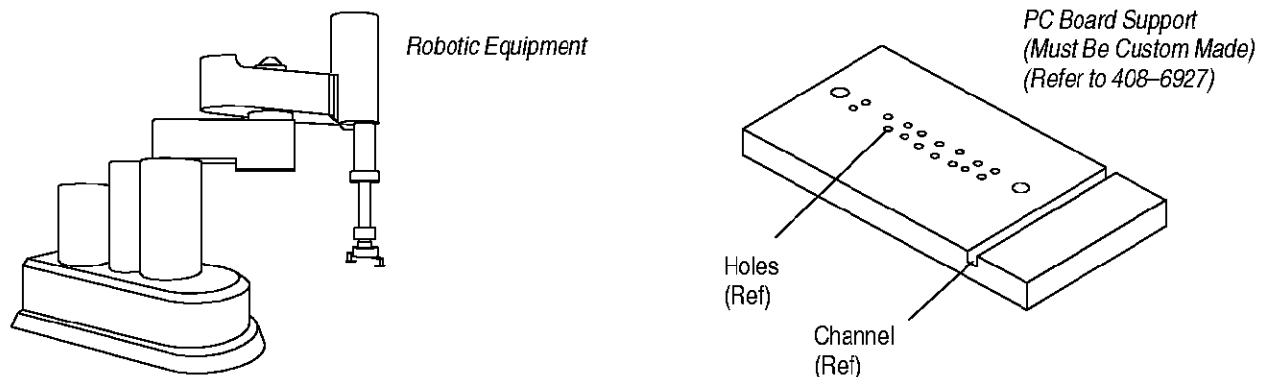
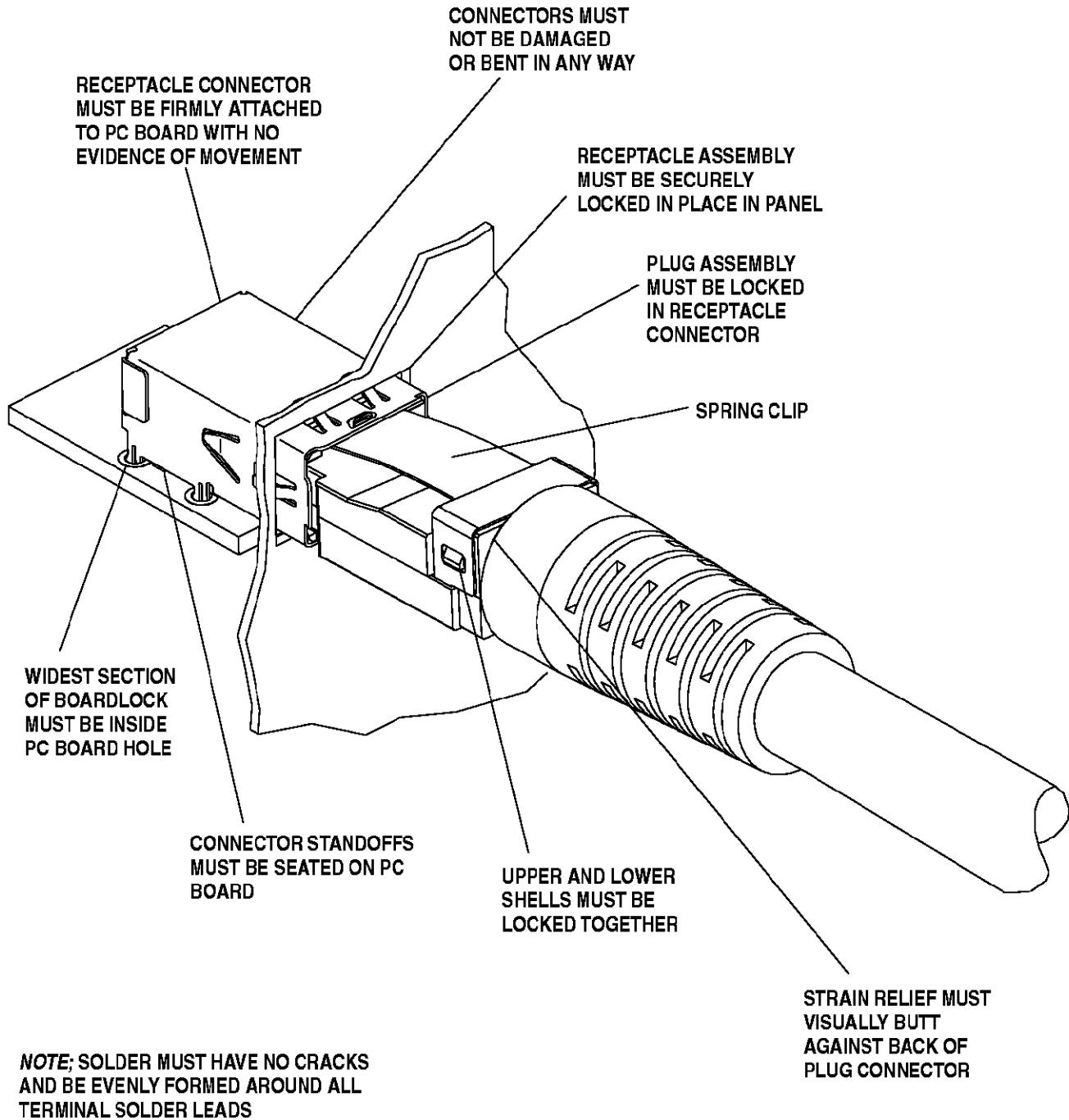

Figure 13

**6. VISUAL AID**

Figure 14 shows a typical application of High Speed Serial Data Connector 2. This illustration should be used by production personnel to ensure a correctly applied product. Applications which DO NOT appear correct should be inspected using the information in the preceding pages of this specification and in the instructional material shipped with the product or tooling.



**FIGURE 14. VISUAL AID**