

RECOMMENDED P.C.B LAYOUT
 GENERAL TOLERANCE: ± 0.05
 AS VIEWED FROM COMPONENT SIDE

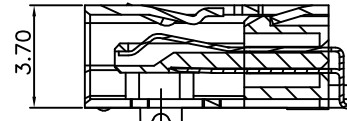
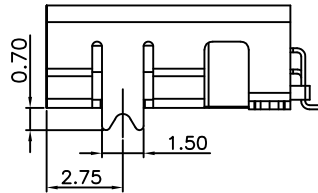
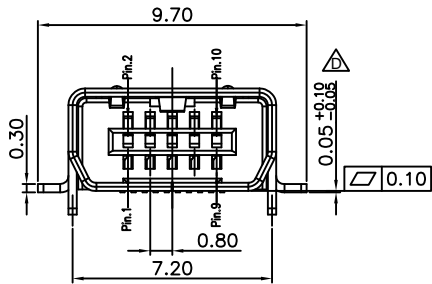
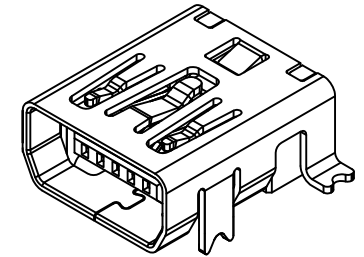

SECTION A-A

Specifications 规格:

Materials 物料规格:

- Plastic Housing 塑胶外壳: LCP UL94V-0 Black \triangle
LCP UL94V-0, 黑色
- Contact Terminal 接触端子: Phosphor Bronze 磷青铜
- Metallic Shell 金属外壳: Brass 黄铜 \triangle

Plating 电镀规格:

- Contact Terminal plating 接触端子部分电镀:
Underplating 底层电镀: Nickel all over 全部镀镍
Contact Area 接触部分: 15 μ " Gold 镀金15 μ "
Solder Tails 焊接末端: Tin 50 μ " 镀锡50 μ " \triangle
- Metallic Shell plating 金属外壳电镀:
Underplating 底层电镀: 50 μ " Min. Nickel all over 全部镀镍最少50 μ "
Finish 表面处理: Matte Tin 50 μ " all over 整体镀雾锡50 μ " \triangle

Electrical 电气规格:

- Voltage Rating 电压额定值: 30VDC
- Current Rating 电流额定值: 1A
- Operating Temperature 工作温度: -20°C to +60°C \triangle
- Contact Resistance 接触电阻值: 50m Ω Max.
- Insulation Resistance 绝缘电阻值: 100M Ω Min (Apply 施加100VDC)
- Dielectric Withstanding Voltage 耐电压: No Discharge or Flash 没有放电或火花 (100VAC is applied for 1 min. 施加100VAC共一分钟)

Mechanical 机械性规格:

- Mating Force 插入力: 35N (3.57KgF) Max.
- Unmating Force 拨出力: 7N (0.71KgF) Min. - 1st mating cycle \triangle
- Unmating Force 拨出力: 3N (0.31KgF) Min. - 5001st mating cycle \triangle
- Durability 耐久性: 5,000 Cycles 5,000次插拔 \triangle

Ordering Grid

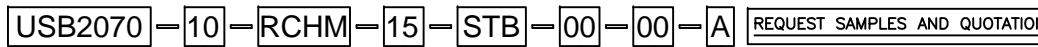

No. of Contacts
10

Contact Plating
15 = 15 μ " Gold

- Packing Options
A = Tape & Reel (With Mylar)
(Quantity per Reel: 800pcs)
- 00 = Without Post
- Offset
00 = No Offset

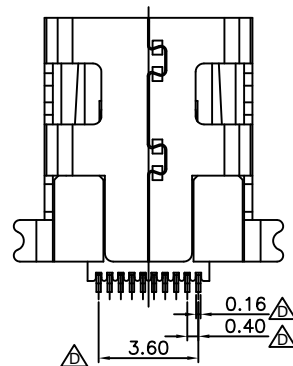

By	LYH	ASE	ASE	SA
DETAIL	DRAWING RELEASE	ECN080331A	ECN080922A	ECN20101104-2
REV DATE	A 13/03/08	B 31/03/08	C 22/09/08	D 04/11/10



Tolerances (Except as noted)	Part Number:-	Date:-
Dimensions in mm	USB2070	13 MAR 08
X.X ± 0.35	Description:-	
X.XX ± 0.25	MINI USB RECEPTACLE, TYPE A/B, 10 PIN, SMT, HORIZONTAL	
X.XXX ± 0.150	THIS DRAWING IS CONFIDENTIAL AND MUST NOT BE COPIED OR DISCLOSED WITHOUT WRITTEN CONSENT	
Third Angle Projection	Scale NTS	Revision D

GCT

www.globalconnectortechnology.com

Material See Note	Drawn by LYH	Sheet No. 1/2
-------------------	--------------	---------------

Global Connector Technology Ltd. - USB2070: Mini USB Receptacle, Type A/B, 10 Pin, SMT, Horizontal

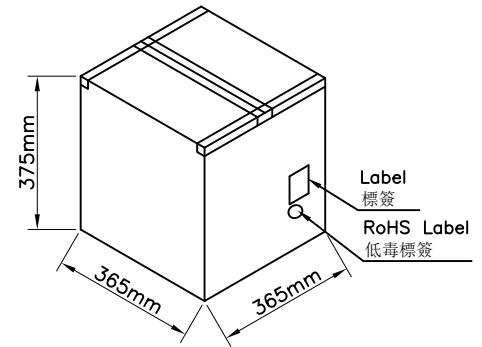
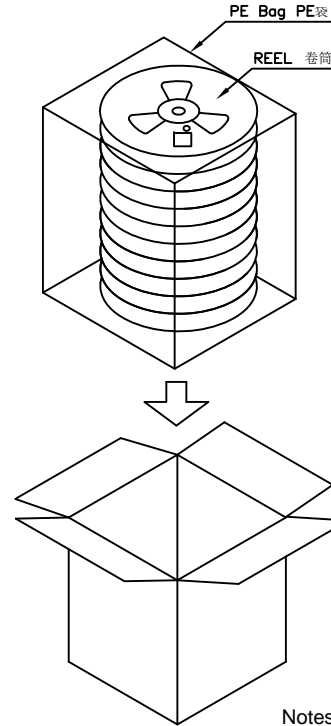
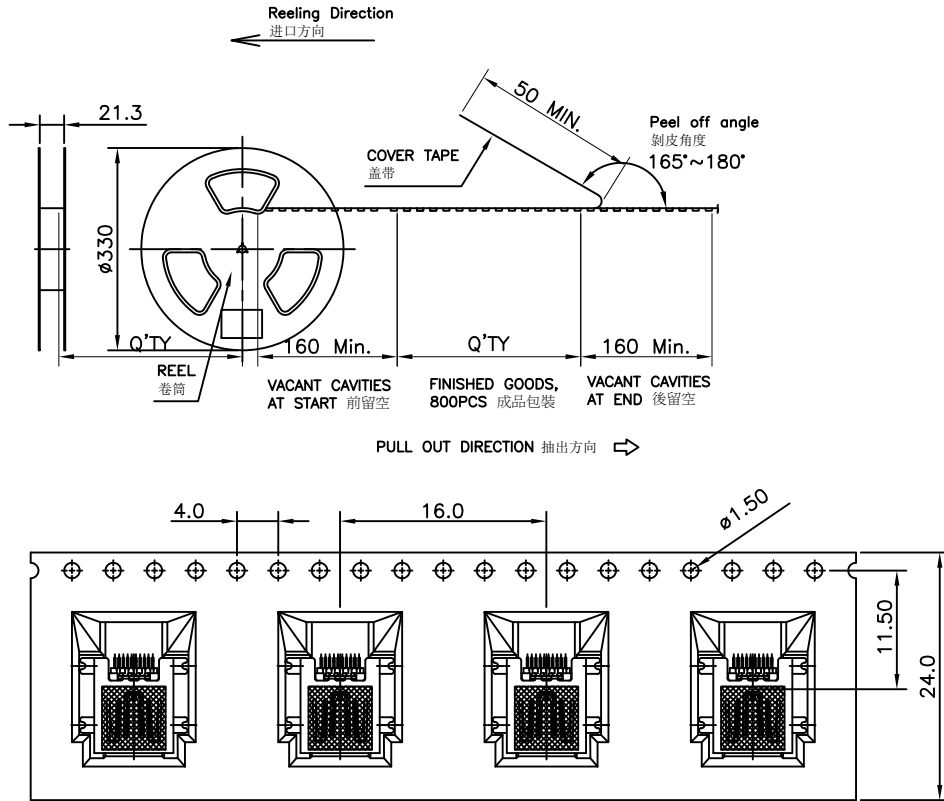

Notes注意:

- All dimensions in millimeters 所有尺寸均是毫米
- Each cavity will hold 1pc. Placement methods are shown in the diagrams. 每穴放置1pc产品, 放置方式如图所示
- The peel-off force between the COVER TAPE & CARRY TAPE is: 0.1N-0.7N (variation within 0.3N). Peel-off angle: 160-180 degree. COVER TAPE与CARRY TAPE剥离力: 0.1N-0.7N (跳动量在0.3N以内) 剥离角度: 160-180度; 剥离速度
- Component Load Per 13" Reel: 800Pcs 每13"卷筒承载零件: 800件

Packing Rules 封装规则:

- All the labels on REEL should be face-up
Reel 标签一律朝上
- Place 11 filled REEL into the bag
以11盘作为一个包装单位, 外包PE袋
- Insert bag into outer box
卷盘使用塑胶袋封装; 然后放入外箱
- Stick label on the outer carton
标签贴放箱外

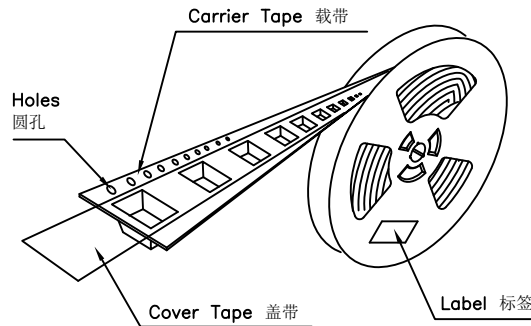

By	LYH	ASE	ASE	SA
DETAIL	DRAWING RELEASE	ECN080331A	ECN080922A	ECN20101104-2
REV DATE	A 13/03/08	B 31/03/08	C 22/09/08	D 04/11/10



Tolerances (Except as noted)	Part Number:-	Date:-
Dimensions in mm	USB2070	13 MAR 08
	Description:-	
	MINI USB RECEPTACLE, TYPE A/B, 10 PIN, SMT, HORIZONTAL	
Third Angle Projection	© THIS DRAWING IS CONFIDENTIAL AND MUST NOT BE COPIED OR DISCLOSED WITHOUT WRITTEN CONSENT	

Scale NTS	Revision D	Material See Note	Drawn by LYH	Sheet No. E & OE 2/2
--------------	---------------	----------------------	-----------------	----------------------------

GCT

www.globalconnectortech.com