

Global Connector Technology Ltd. - USB2060: Mini USB Receptacle, Type B, 5 Pin, SMT, Horizontal

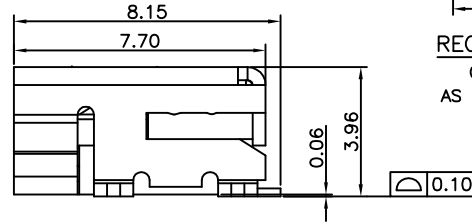

**RECOMMENDED P.C.B LAYOUT**  
 GENERAL TOLERANCE: ±0.05  
 AS VIEWED FROM COMPONENT SIDE  
 [Hatched Area] Solder Area  
 [Dashed Outline] Component Outline

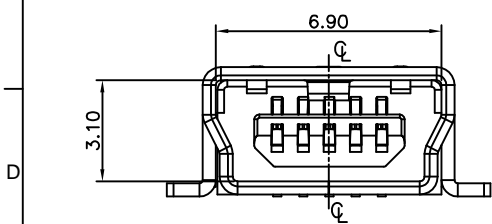
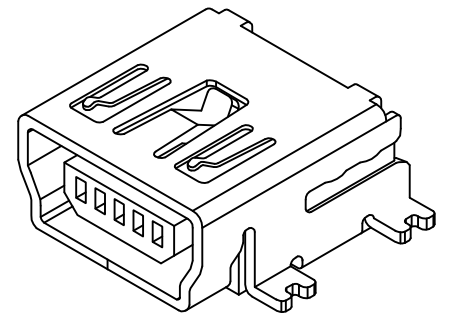
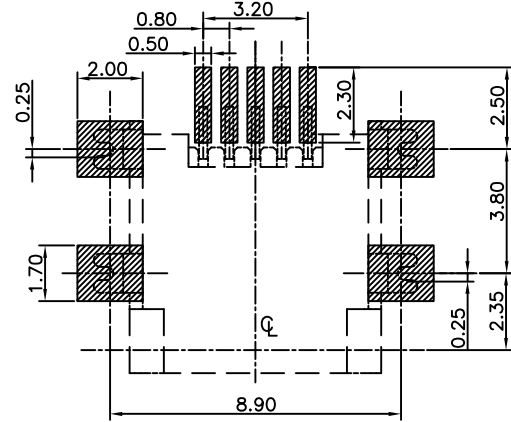
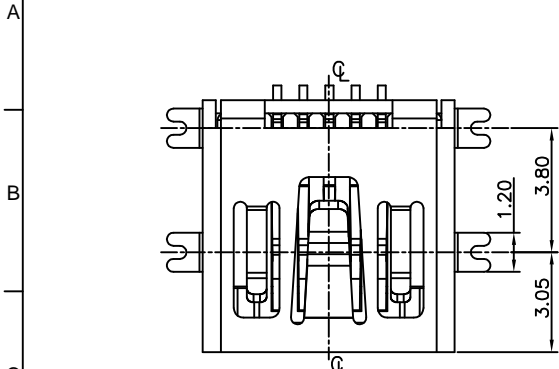
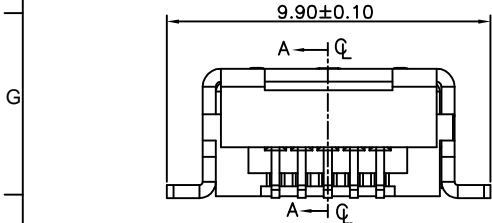
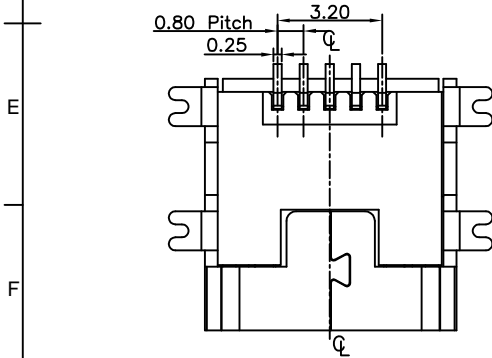

**Ordering Grid**

USB2060 - 05 - RBHM - 15 - SLB - 00 - 00 - A

REQUEST SAMPLES AND QUOTATION

No. of Contacts: 05

Contact Plating: 15 = 15µ" Gold

Packing Options: A = Tape & Reel (with Mylar) (Quantity per Reel: 800 pcs)

00 = Without Post

Offset: 00 = No Offset

**Specifications 规格:**

**Materials 物料规格:**

Plastic Housing 塑胶外壳: High Temp. Thermoplastic with 30% Glass Fiber, UL94V-0, Black 高温塑胶(含30%玻璃纤维), 黑色  
 Contact Terminal 接触端子: Phosphor Bronze, T=0.25mm 磷青铜, T=0.25mm  
 Metallic Shell 金属外壳: Stainless Steel, T=0.4±0.01mm 不锈钢

**Plating 电镀规格:**

Contact Terminal plating 接触端子部分电镀:  
 Underplating 底层电镀: Nickel all over 全部镀镍  
 Contact Area 接触部分: 15µ" Gold 镀金15µ"  
 Solder Tails 焊接末端: Tin 镀锡  
 Metallic Shell plating 金属外壳电镀: Copper Alloy 外壳物料: 铜合金  
 Underplating 底层电镀: Nickel all over 全部镀镍  
 Solder Tails 焊接末端: Matte Tin 镀雾锡

**Electrical 电气规格:**

Voltage Rating 电压额定值: 30VDC  
 Current Rating 电流额定值: 1A  
 Operating Temperature 工作温度: 0°C to +50°C  
 Contact Resistance 接触电阻值: 50mΩ Max.  
 Insulation Resistance 绝缘电阻值: 100MΩ Min (Apply 施加100VDC)  
 Dielectric Withstanding Voltage 耐电压: No Discharge or Flash (Apply 100VAC for 1 min. 施加100VAC共一分钟)

**Mechanical 机械性规格:**

Mating Force 插入力: 35N (3.57KgF) Max.  
 Unmating Force 拔出力: 7N (0.71KgF) Min.  
 Contact Retention Force 接触保持力: 4N Min.  
 Durability 耐久性: 5,000 Cycles 5000次插拔

By	LYH	ASE	SA
DETAIL	DRAWING RELEASE	ECN080402A	PACK QTY UPDATE
REV DATE	A 11/07/07	B 02/04/08	C 28/06/10



Tolerances (Except as noted)	Part Number:-	Date:-
Dimensions in mm	USB2060	11 JUL 07
X.X ± 0.35 X.XX ± 0.25 X.XXX ± 0.150	Description:-	
X.° ± 1° X.X° ± 0.5° X.XX° ± 0.25°	MINI USB RECEPTACLE, TYPE B, 5 PIN, SMT, HORIZONTAL	
Third Angle Projection	THIS DRAWING IS CONFIDENTIAL AND MUST NOT BE COPIED OR DISCLOSED WITHOUT WRITTEN CONSENT	

**GCT**

www.globalconnectortechonology.com

Scale NTS	Revision C	Material See Note	Drawn by LYH	E & OE	Sheet No. 1/2
-----------	------------	-------------------	--------------	--------	---------------

Global Connector Technology Ltd. - USB2060: Mini USB Receptacle, Type B, 5 Pin, SMT, Horizontal

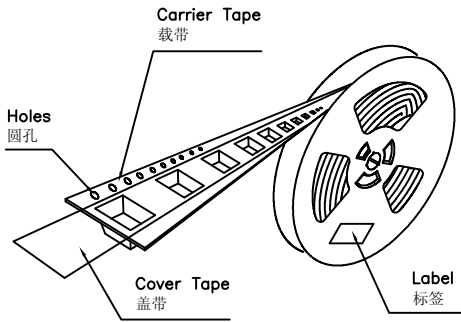
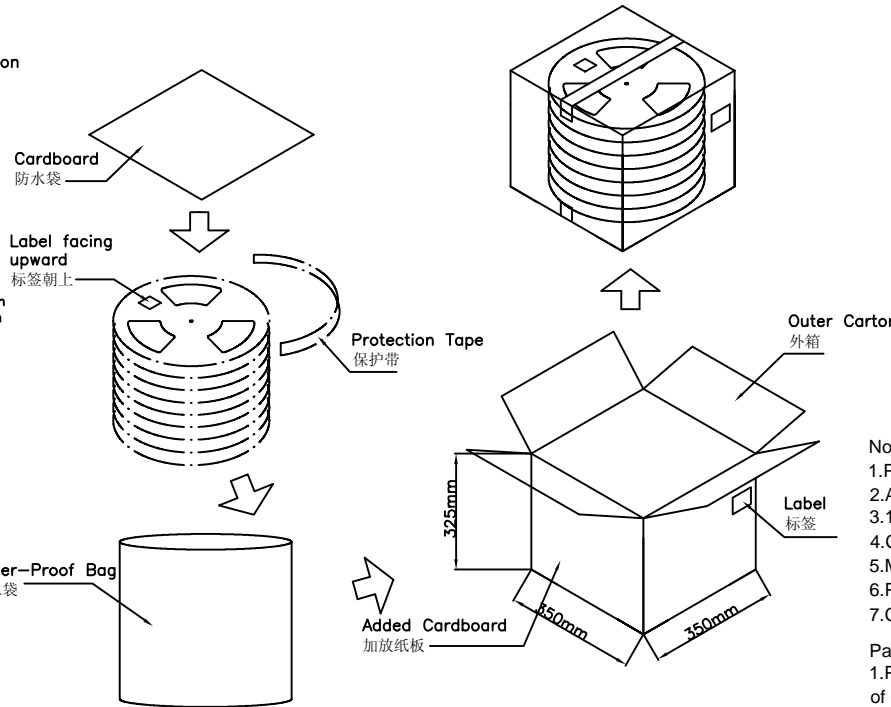
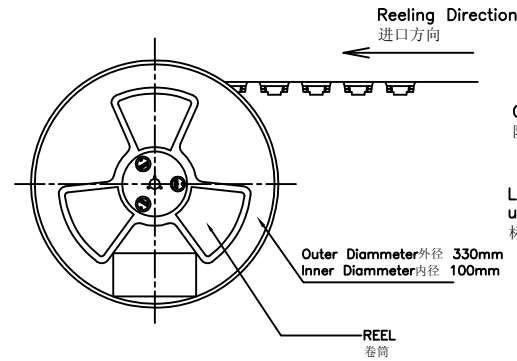
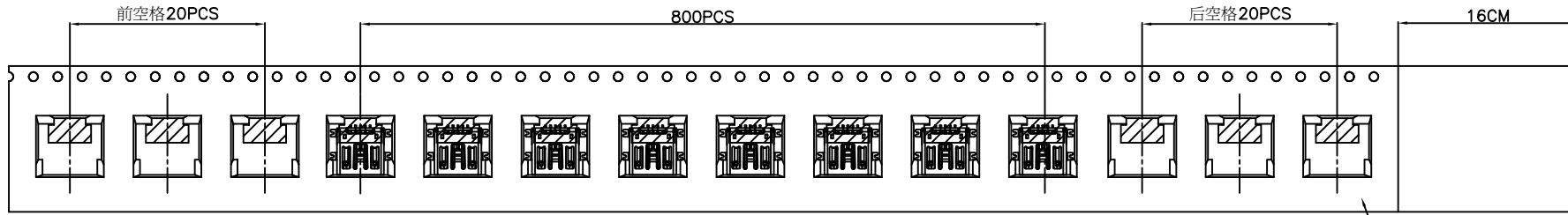

Notes注意:

- 1.Part Conforms to EIA-481-C Standards 产品符合EIA-481-C标准
- 2.All dimensions in millimeters [inches] 所有尺寸均是毫米[英寸]
- 3.10 sprocket hole pitch cumulative tolerance±0.2mm
- 4.Carrier camber is within 1mm in 100mm 装料带弧:每100mm少于1mm
- 5.Marerial:BLACK Polystyrene. 材料:黑色:聚苯乙烯
- 6.Packing Length Per 22' Reel:36Meters 每22"卷筒包装长度:36米
- 7.Component Load Per 13'Reel:800Pcs 每13"卷筒承载零件:800件

Packing Rules封装规则:

- 1.Place a hard cardboard at the bottom of outer carton 外箱底部加纸板
- 2.All the labels on REEL should be face-up Reel标签一律朝上
- 3.Place 10 filled REEL into the water-proof bag 把10卷装好的产品平放防水袋
- 4.Place a hard cardboard on top 上加放纸板
- 5.Stick label on the outer carton 标签贴放箱外

By	LYH	ASE	SA
DETAIL	DRAWING RELEASE	ECN080402A	PACK QTY UPDATE
REV DATE	A 11/07/07	B 02/04/08	C 28/06/10



Tolerances (Except as noted)	Part Number:- USB2060	Date:- 11 JUL 07
Dimensions in mm	Description:- MINI USB RECEPTACLE, TYPE B, 5 PIN, SMT, HORIZONTAL	
Third Angle Projection	© THIS DRAWING IS CONFIDENTIAL AND MUST NOT BE COPIED OR DISCLOSED WITHOUT WRITTEN CONSENT	

**GCT**

www.globalconnectortechology.com

Scale NTS	Revision C	Material See Note	Drawn by LYH	E & OE	Sheet No. 2/2
--------------	---------------	----------------------	-----------------	--------	------------------