



ALL RIGHTS RESERVED. NO PORTION OF THIS PUBLICATION, WHETHER IN WHOLE OR IN PART, CAN BE REPRODUCED WITHOUT THE EXPRESS WRITTEN CONSENT OF SPC TECHNOLOGY.

SPC-F005.DWG

REVISIONS

DOC. NO. SPC-F005 * Effective: 7/8/02 * DCP No: 1398

DCP #	REV	DESCRIPTION	DRAWN	DATE	CHECKD	DATE	APPRVD	DATE
809	A	RELEASED	JWM	8/14/02	JC	8/15/02	DJC	8/15/02

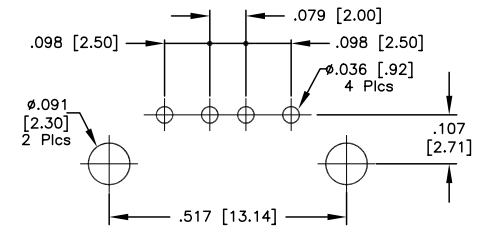
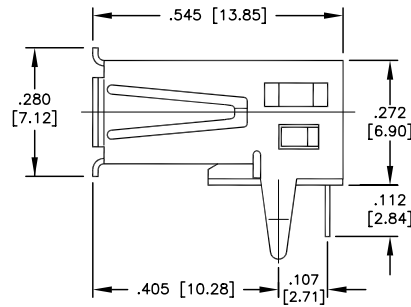
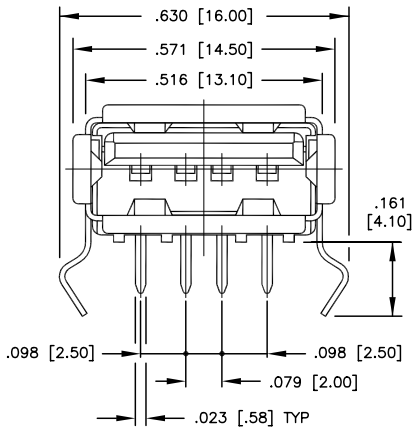

SUGGESTED MOUNTING CONFIGURATION

SPECIFICATIONS

SINGLE, OPEN BACK, OFF WHITE

HOUSING:

THERMOPLASTIC, GLASS FIBER FILL, UL94V-0.

CONTACT:

PHOSPHOR BRONZE, GOLD PLATING ON CONTACT INTERFACE AND TIN-LEAD PLATING ON SOLDER TAIL, ALL OVER NICKEL UNDERPLATING.

SHELL:

PHOSPHOR BRONZE, TIN-LEAD PLATING OVER NICKEL PLATING

ELECTRICAL:

INSULATION RESISTANCE: 1000 milliohm (MIN)
 DIELECTRIC WITHSTAND VOLTAGE: 750 VAC
 VOLTAGE: 30 VAC (RMS)
 CURRENT: 1.0 AMP PER CONTACT
 CONTACT RESISTANCE: 30 milliohm (MAX)

MECHANICAL:

MATING FORCE: 35 NEWTONS (MAX)
 UNMATING FORCE: 10 NEWTONS (MIN)

ENVIRONMENTAL:

TEMPERATURE RANGE: -55°C TO +85°C

DISCLAIMER:
 ALL STATEMENTS AND TECHNICAL INFORMATION CONTAINED HEREIN ARE BASED UPON INFORMATION AND/OR TESTS WE BELIEVE TO BE ACCURATE AND RELIABLE. SINCE CONDITIONS OF USE ARE BEYOND OUR CONTROL, THE USER SHALL DETERMINE THE SUITABILITY OF THE PRODUCT FOR THE INTENDED USE AND ASSUME ALL RISK AND LIABILITY WHATSOEVER IN CONNECTION THEREWITH.

TOLERANCES:

UNLESS OTHERWISE SPECIFIED, DIMENSIONS ARE FOR REFERENCE PURPOSES ONLY.

DRAWN BY:	DATE:
Jeff McVicker	8/14/02
CHECKED BY:	DATE:
JOHN COLE	8/15/02
APPROVED BY:	DATE:
Daniel Carey	8/15/02

DRAWING TITLE: USB TYPE A FEMALE R/A PCB MOUNT CONNECTOR			
SIZE	DWG. NO.	ELECTRONIC FILE	REV
A	SPC4933	50N156.DWG	A
SCALE: NTS	U.O.M.: INCHES [mm]	SHEET: 1 OF 1	