

This document is the property of Amphenol Corporation and is delivered on the express condition that it is not to be disclosed, reproduced or used, in whole or in part, for manufacture or sale by anyone other than Amphenol Corporation without the prior consent, & that no right is granted to disclose or to use any information in this document.

REVISIONS				
SYM	ECN	DESCRIPTION	DATE	APPROVED
A	HK	INITIAL RELEASE	01/08/03	Y.M.LEE
B	HK	ADD CHOP OF ROHS	2/15/06	Y.M.LEE

PUT THE LATCHING SCREW THRU THE HOLE ON LEFT END OF CONNECTOR. THE SCREW HOLDS THE SHELLS TOGETHER & IS RETAINED BY THREADS IN THE HOOD.

TO ASSEMBLE CONNECTOR, SLIDE THE HOOD (FROM LEFT TO RIGHT ON ILLUSTRATION) IN SUCH A MANNER THAT THE 2 TABS OF THE BRACKET ENTER THE SLOTS OF THE HOOD.

TABLE 1

CONNECTOR SIZES	AVERAGE MATING FORCE (POUNDS)
14	5
24	8
36	12
50	15
64	19

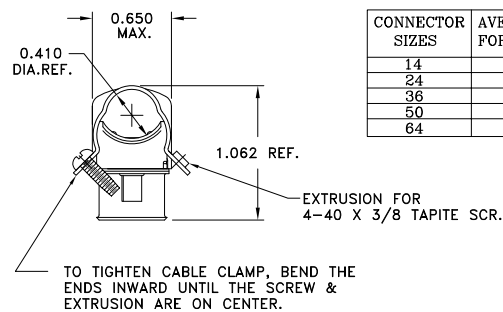
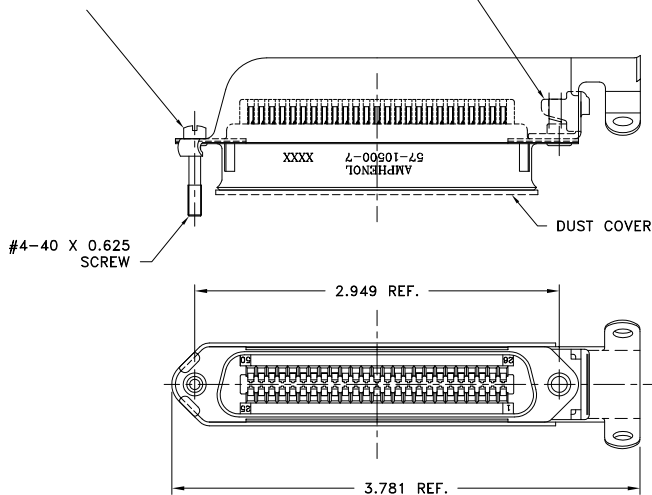

- 11) CONTACT RETENTION FORCE: 2 LBS MAX.
- 12) DURABILITY: 250 CYCLES MIN.
- 13) VIBRATION: NO INTERRUPTIONS < 1u SEC.
- 14) OPERATING TEMPERATURE: -55°C TO +105°C (-67°F TO +221°F)
- 15) METAL HOOD, SCREWS AND DUST COVER ARE SHIPPED LOOSE IN BULK PACK.
- 16) CONNECTOR ASSEMBLED FOR ILLUSTRATION ONLY.

SPECIFICATIONS:

- 1) SOLDER CUP CONTACT: TO ACCOMMODATE 22-30 AWG SOLID AND 24-30 STRANDED CONNECTOR WIRES.
- 2) DIELECTRIC: DIALYL-PHTHALATE PER MIL-M-14F TYPE MDG UL-94V0
- 3) CONTACT MATERIAL: COPPER ALLOY
- 4) CONTACT: 20 MICRO-INCHES MIN. GOLD MATING AREA: 3-5 MICRO-INCHES GOLD TERMINAL AREA: 50 MICRO-INCHES MIN. NICKEL UNDERPLATING ALL OVER.
- 5) SHELL MATERIAL: ZINC PLATED STEEL WITH CLEAR CHROMATE COATING
- 6) CURRENT CAPACITY: 5 AMPS/CONTACT
- 7) VOLTAGE RATING: 700 VOLTS D.C. AT SEA LEVEL
200 VOLTS D.C. AT 70,000 FEET
- 8) INSULATION RESISTANCE: >5000 M OHM
- 9) DIELECTRIC WITHSTANDING VOLTAGE: 1200 VAC (RMS) AT SEA LEVEL
- 10) CONNECTOR MATING FORCE: REFER TO TABLE 1.

CUSTOMER INFORMATION DRAWING

ITEM NO	PART OR IDENTIFICATION NO	NOMENCLATURE OR DESCRIPTION	QTY REQ'D
PARTS LIST			
UNLESS OTHERWISE SPECIFIED TOLERANCES		APPROVAL	DATE
U.S. METRIC		DRAWN JS.GUO	2/15/08
X +/- 0.030		CHECKED	
.XX +/- 0.010		CHECKED	
.XXX +/- 0.005			
FRACTIONS +/- .1"		DRAWING FILE :	
ANGLES +/- 1°		\\DRAWING\97\C57105007.DWG	
FOR MATERIALS AND FINISHES SEE NOTES		ANGLE OF PROJECTION	
REMOVE SHARP EDGES			
DIMENSIONS			
U.S.	INCHES		
(METRIC)	(MM)		
TITLE		SIZE	REV.
50 CONTACT PLUG ASSEMBLY		A3	B
RUNNING CABLE 1-26 END		DRAWING NO.	
HIGH BARRIER, DUST COVER		C57-10500-7	
SCALE	NONE	SHEET 1 OF 1	