

This document is the property of Amphenol Corporation and is delivered on the express condition that it is not to be disclosed, reproduced or used, in whole or in part, for manufacture or sale by anyone other than Amphenol Corporation without its prior consent, & that no right is granted to disclose or to use any information in this document.

REVISIONS				
SYM	ECN	DESCRIPTION	DATE	APPROVED
A	HK	PRELIMINARY RELEASE	11/20/02	Y.M.LEE
B	HK	ADD CHOP OF ROHS	5/4/06	IP

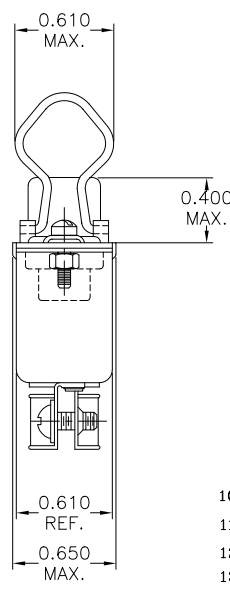
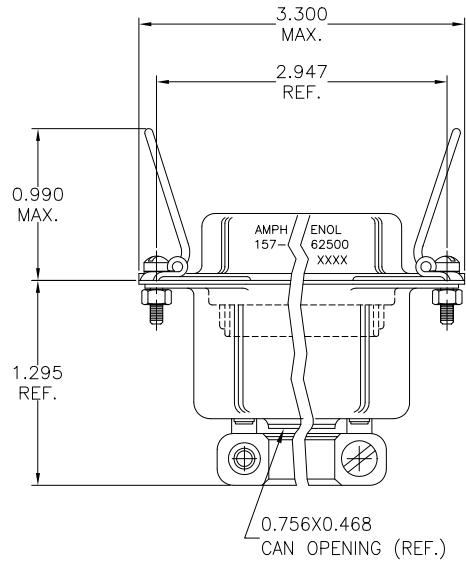

TABLE 1

CONNECTOR SIZES	AVERAGE MATING FORCE (POUNDS)
14	5
24	8
36	12
50	15
64	19

- 10) DIELECTRIC WITHSTANDING VOLTAGE: 1200 VAC (RMS) AT SEA LEVEL
- 11) CONNECTOR MATING FORCE: REFER TO TABLE 1.
- 12) CONTACT RETENTION FORCE: 2 LBS MAX.
- 13) DURABILITY: 250 CYCLES MIN.
- 14) VIBRATION: NO INTERRUPTIONS < 1u SEC.
- 15) OPERATING TEMPERATURE: -55°C TO +105°C (-67°F TO +221°F)

SPECIFICATIONS:

- 1) INSULATION DISPLACEMENT CONTACTS: TO ACCOMMODATE 24-26 AWG SOLID AND 26-28 STRANDED CONNECTOR WIRES.
- 2) DIELECTRIC: PBT GLASS FIBER RE-INFORCED, UL-94V0
- 3) CONTACT MATERIAL: COPPER ALLOY
- 4) CONTACT: 20 MICRO-INCHES MIN. GOLD MATING AREA: 3-5 MICRO-INCHES GOLD TERMINAL AREA: 50 MICRO-INCHES MIN. NICKEL UNDERPLATING ALL OVER.
- 5) SHELL MATERIAL: ZINC PLATED STEEL.
- 6) BAIL LATCH MATERIAL: STAINLESS STEEL WIRE, PASSIVATED FINISH.
- 7) CURRENT CAPACITY: 5 AMPS/CONTACT
- 8) VOLTAGE RATING: 700 VOLTS D.C. AT SEA LEVEL
200 VOLTS D.C. AT 70,000 FEET
- 9) INSULATION RESISTANCE: >5000 M OHM

CUSTOMER INFORMATION DRAWING

ITEM NO	PART OR IDENTIFICATION NO	NOMENCLATURE OR DESCRIPTION	QTY REQ'D
PARTS LIST			
UNLESS OTHERWISE SPECIFIED TOLERANCES		APPROVAL	DATE
U.S. METRIC		DRAWN XS.GUO	5/4/06
.X +/- 0.020		CHECKED	
.XX +/- 0.010		CHECKED	
.XXX +/- 0.005			
FRACTIONS +/-			
ANGLES +/- 1°		DRAWING FILE :	
FOR MATERIALS AND FINISHES SEE NOTES		\DRAWING\157\C15762500.DWG	
REMOVE SHARP EDGES		ANGLE OF PROJECTION	
DIMENSIONS			
U.S. INCHES			
-(METRIC)-			
		TITLE 50 CONTACT RECEPTACLE ASSEM, CABLE MOUNT-MICROPIERCE, MODIFIED BACK SHELL	
		SIZE DRAWING NO.	REV.
		A3 C157-62500	B
		SCALE NONE	SHEET 1 OF 1