

REV	DATE	BY	APPROV
1			
2			
3			
4			
5			
6			
7			
8			
9			
10			
11			
12			
13			
14			
15			
16			
17			
18			
19			
20			
21			
22			
23			
24			
25			
26			
27			
28			
29			
30			
31			
32			
33			
34			
35			
36			
37			
38			
39			
40			
41			
42			
43			
44			
45			
46			
47			
48			
49			
50			
51			
52			
53			
54			
55			
56			
57			
58			
59			
60			
61			
62			
63			
64			
65			
66			
67			
68			
69			
70			
71			
72			
73			
74			
75			
76			
77			
78			
79			
80			
81			
82			
83			
84			
85			
86			
87			
88			
89			
90			
91			
92			
93			
94			
95			
96			
97			
98			
99			
100			

MATERIAL:  
 CONNECTOR ASSEMBLY:  
 REAR BODY: GLASS FILLED POLYESTER, PBT  
 PLUNGER: ALUMINUM ALLOY  
 FERRULE: MINERAL FILLED PAS\*  
 COUPLING NUT: NICKEL PLATED ZINC  
 INTERNAL COMPONENTS: RUBBER, COLOR: BLACK  
 SPRING: STAINLESS STEEL  
 PROTECTIVE COVER: LDPE, COVER: BLACK, NON-FR  
 STEPPED CRIMP EYELET: NICKEL PLATED COPPER  
 POLYMER TUBING: TYGON, COLOR: CLEAR  
 HYTREL, COLOR: WHITE  
 PVC, COLOR: BLACK  
 STRAIN RELIEF: POLYOLEFIN ELASTOMER, COLOR: BLACK, NON-FR  
 BARE BUFFER BOOT: POLYOLEFIN ELASTOMER, COLOR: BLACK\*  
 \*UL94 V-0 RATED AT QUALIFYING THICKNESS.

2. THIS KIT WILL TERMINATE:  
 900um TIGHT BUFFERED FIBER  
 250um COATED FIBER  
 2.0-3.0mm JACKETED CABLE

BULK PACKAGE.

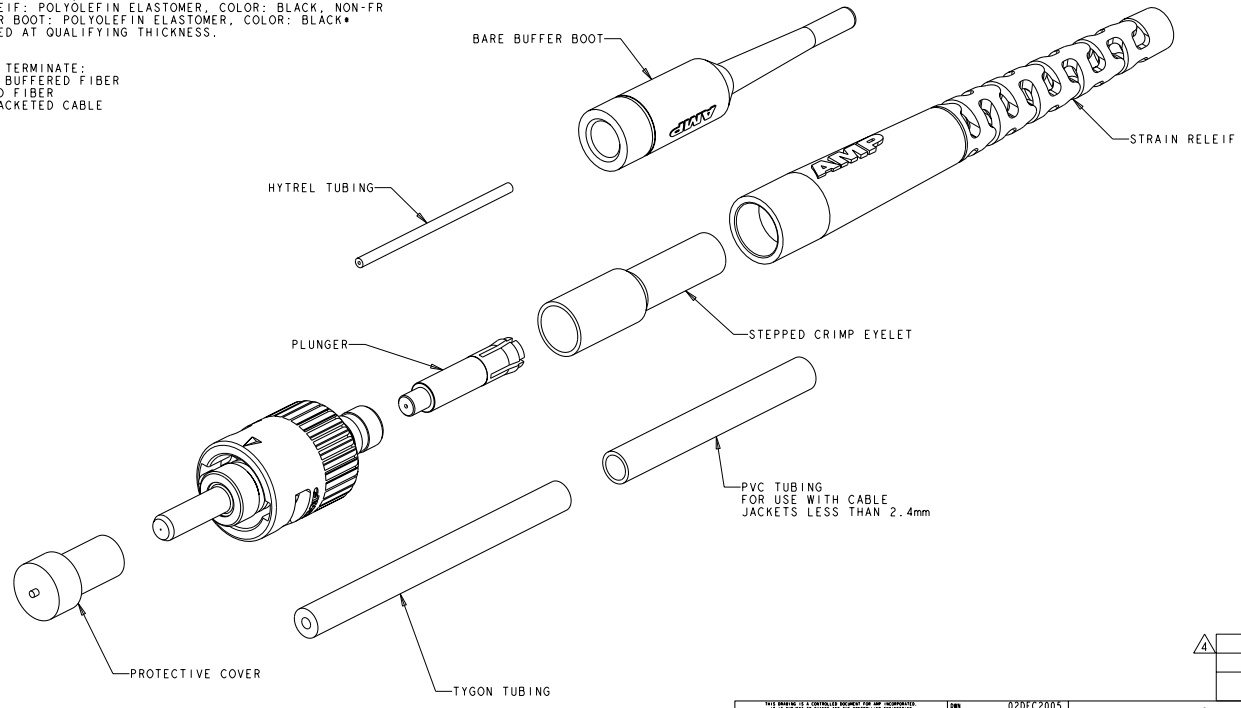

5492168-2
5492168-1
PART NO

THIS DRAWING IS UNPUBLISHED. RELEASED FOR PUBLICATION. ALL RIGHTS RESERVED.		DATE: 02DEC2005 BY: B. BRIGGS CHK: L. SAUERWEIN APPR: S. BUCHNER	AMP Incorporated Harrisburg, PA 17105-3608
DIMENSIONS: mm TOLERANCES UNLESS OTHERWISE SPECIFIED: 0 PLC ±0.1 1 PLC ±0.1 2 PLC ±0.05 3 PLC ±0.005 4 PLC ±0.005 ANGLES ±0.5°	PRODUCT SPEC: - APPLICATION SPEC: - WEIGHT: - FINISH: -	NAME: CONNECTOR KIT, LightCrimp NextC, 125µm SIZE: A2 CASE CODE: 00779 DRAWING NO: 5492168	RESTRICTED TO: - SCALE: 4:1 SHEET: 1 OF 1 REV: A
MATERIAL: - FINISH: -		CUSTOMER DRAWING	DATE: 02DEC2005