



ALL RIGHTS RESERVED. NO PORTION OF THIS PUBLICATION, WHETHER IN WHOLE OR IN PART, CAN BE REPRODUCED WITHOUT THE EXPRESS WRITTEN CONSENT OF SPC TECHNOLOGY.

SPC-F005.DWG

REVISIONS

DOC. NO. SPC-F005 * Effective: 7/8/02 * DCP No: 1398

DCP #	REV	DESCRIPTION	DRAWN	DATE	CHECKD	DATE	APPRVD	DATE
1789	A	RELEASED	DCM	6/2/06	YA	8/2/06	JWM	8/2/06

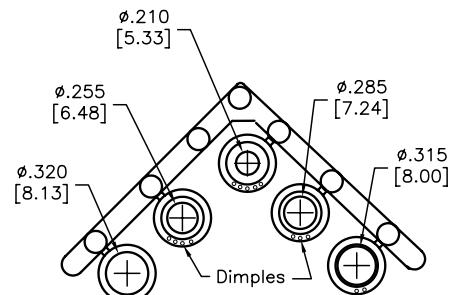
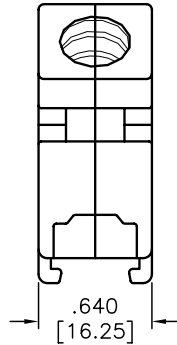
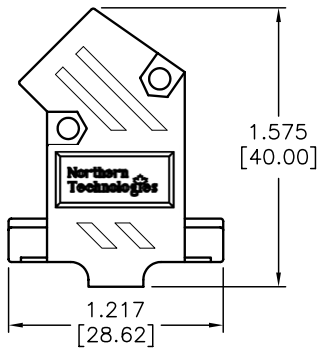
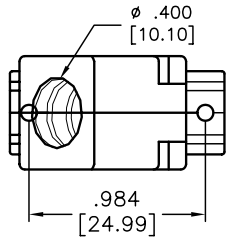

Compression Inserts
Material: Thermoplastic
Color: Black
Durometer: 75±5 Type A Per ASTM D2240

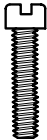
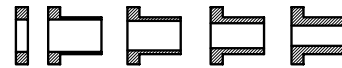

#4-40 x 7/6", fillister head machine screw, C1018 Steel, Zinc Plated (Hexavalent Chromium Free) (2 pcs)



#4-40, #2 Blank Hex Nut, C1010 Steel, Zinc Plated (Hexavalent Chromium Free) (2 pcs)



#4-40 x 1/2", fillister head captive screw, C1018 Steel, Zinc Plated (Hexavalent Chromium Free) (2 pcs)

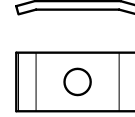

#4 Saddle Washer, C.R. Steel, Zinc Plated (Hexavalent Chromium Free) (2 pcs)

DISCLAIMER:
ALL STATEMENTS AND TECHNICAL INFORMATION CONTAINED HEREIN ARE BASED UPON INFORMATION AND/OR TESTS WE BELIEVE TO BE ACCURATE AND RELIABLE. SINCE CONDITIONS OF USE ARE BEYOND OUR CONTROL, THE USER SHALL DETERMINE THE SUITABILITY OF THE PRODUCT FOR THE INTENDED USE AND ASSUME ALL RISK AND LIABILITY WHATSOEVER IN CONNECTION THEREWITH.

TOLERANCES:
UNLESS OTHERWISE SPECIFIED, DIMENSIONS ARE FOR REFERENCE PURPOSES ONLY.

DRAWN BY:	DATE:
Dan McVicker	6/2/06
CHECKED BY:	DATE:
Yilmaz Akyondem	8/2/06
APPROVED BY:	DATE:
Jeff McVicker	8/2/06

DRAWING TITLE: 9 Pin D-Sub Cover, Metalized Plastic, 45 Degree Exit			
SIZE	DWG. NO.	ELECTRONIC FILE	REV
A	SPC14994	80K5404.dwg	A
SCALE: NTS	U.O.M.: INCHES [mm]	SHEET: 1 OF 1	