

Features

- Complete FM Receiver and Decoder.
- Small Form Factor
- Range up to 200 Metres
- Easy Learn Transmitter Feature.
- Learns 40 transmitter Switches
- 4 Digital and 1 Serial Data outputs
- Outputs, Momentary or Latching.
- Minimal external components
- Direct Led Drive Shows Data Reception
- Secure Data Protocol
- 5V Supply
- CE Compliant for Licence Free Use
- Compatible with
 - RF800 series Encoder IC's
 - HORNET, FIREFLY, and 205 series transmitters

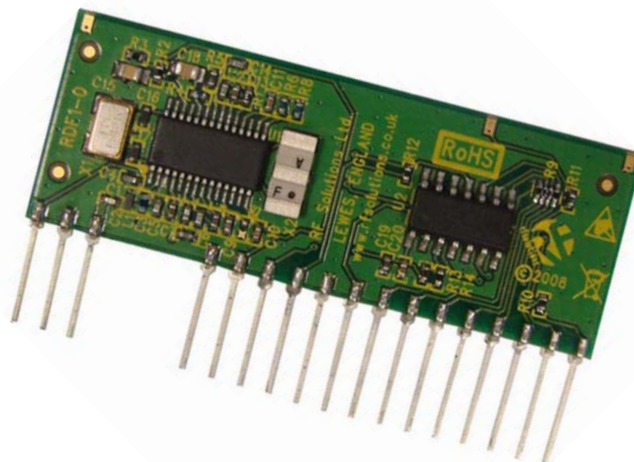

Applications

- Remote Control
- Radio Telemetry
- RFID

Description

The RDF1 is a complete FM receiver and decoder module in one, providing a complete radio system with up to four digital outputs and single serial data output when used with an RF Solutions FIREFLY, HORNET or 205 series Handheld transmitters. Dependant on the transmitter, a system using the RDF1 can achieve up to 200m range.

The RDF1 module consists of a front end super-heterodyne receiver and an embedded microcontroller which decodes the RF string for a compatible transmitter and outputs to 4 telemetry lines and as serial data.

The module has an easy-to-use 'LEARN' facility, and is capable of storing up to 40 pairings within its internal in non volatile memory (EEPROM).

Part Numbers

Part Number	Description	Compatible Transmitters and Encoders
RDF1-433	Superheterodyne Receiver Decoder FM, 433MHz	FIREFLY HORNET 205 RF800 Chipsets

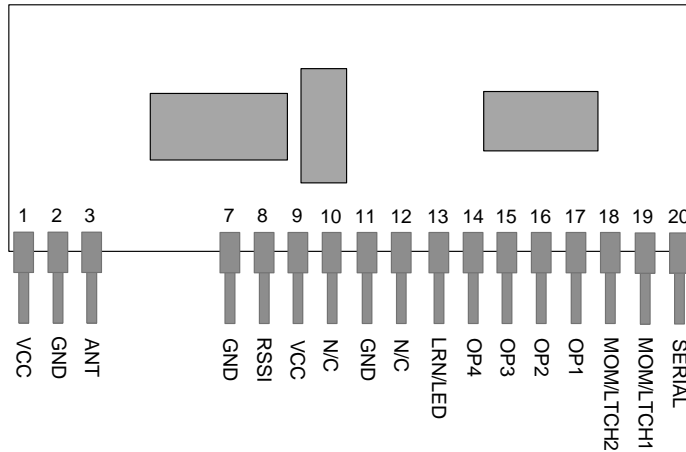
Pin Description

Pin No	Name	I/O	Description
1	VCC	-	The power supply needs to be a stable regulated 5V with <10mV ripple
2	GND	-	RF ground
3	RFIN	I	RF input (Antenna) Connection
4 – 6	N/C	N/A	Not Connected
7	GND	-	RF Ground Connection
8	RSSI	O	Received signal strength indicator
9	VCC	-	5 V Power Supply
10	N/C	N/A	Not Connected
11	GND	-	Ground Connection
12	N/C	N/A	Not Connected
13	LRN/LED	I/O	Multi Function Pin This input is used to set the decoder module to 'Learn Mode' and for the 'Erase Function' it is also used to drive the Status LED.
14	OP4	O	These outputs normally high and are asserted LOW when the relevant inputs of a learnt transmit device are asserted.
15	OP3	O	
16	OP2	O	
17	OP1	O	
18	MOMLTCH2	I	These pins are read on power up to set the action of outputs 1-4. Momentary action is set by a connection to ground. Latching is set using open circuit. See table on P4
19	MOMLTCH1	I	
20	SERIAL	O	In normal run mode this pin outputs serial data on reception of a valid data string.

RDF1 Application Circuit

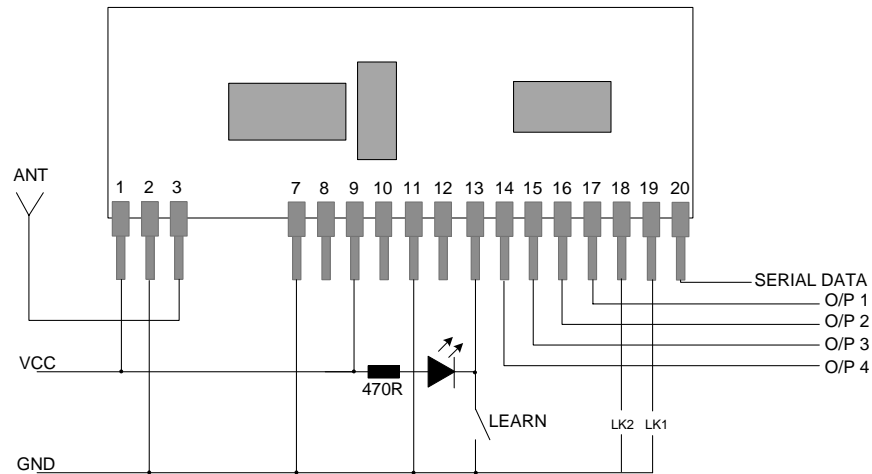

The RDF1 requires only the addition of the following components

1. A '**Learn**' switch which is used in the process of learning a transmitter/encoder to the decoder and also to initiate erasure of encoder information.
2. An **LED** and series **Resistor 470 Ohm** which indicates the status of the learn process, the erase process and also data reception status.
3. Two **Option links** (LK1 and LK2) which configure the action of the digital outputs.

Custom versions of this product are available, please contact our sales department for further details

Compatibility with RF Solutions Transmitters:

All RDF1 receiver decoders are compatible with the HORNET, FIREFLY, and 205 series of ready to operate Handheld transmitters.

This enables a designer to integrate a remote control function easily into an application using a ready made transmitter.



System and Functional operation

Digital Data Outputs

Each RF Solutions transmitter contains a secure serial identity. When a switch is pressed, the transmitter emits a unique secure RF signal. The Receiver can learn this signal and allocate it to any of its output(s).

Any transmitter switch may be paired to one or many of a receiver's outputs, Many transmitters switches may be paired to a single receiver output.

This enables

- One transmitter switch to control many receivers outputs, or,
- Many transmitters switches to control one receiver output

The only limitation is that each receiver has a maximum capacity of 40 pairings, (can be from the same or any number of transmitters).

Hint: the same transmitter may be taught to any number of receivers to create 'master keys'.

Learn: Learn Mode activation is achieved by pulling this input to GND briefly

Pairing Procedure (Learning a Transmitter Switch to RDF1 digital output) (as application circuit)

1. Select the receiver output to learn onto:
 - a. Briefly operate the RDF1 Learn switch once
 - b. The Learn LED will flash once to indicate output 1 is selected
 - c. After the LED stops flashing, press the Learn switch again to select the next output channel.
 - d. Repeat step c until the required output is selected.
2. Operate the Transmitter button that you want to learn to the selected RDF1 output.
3. The Learn LED will then illuminate, operate the same transmitter button again.
4. The Learn LED will then flash to indicate learning is complete.

Erase Mode: Erase Mode is achieved by pulling this input to GND for >8 seconds. This causes the internal EEPROM to be erased of all pre-learned Transmitter pairings.

Digital Output Configuration : Momentary or Latching

These high impedance inputs are used to set the digital outputs to momentary or latched actions

Mom : This output is valid for the duration of valid key press of the transmitter switch

Latch: This output changes state on each valid transmitter switch press.

Link Positions		Digital Outputs			
Link1	Link2	O/P 1	O/P 2	O/P 3	O/P 4
Closed	Closed	Mom	Mom	Mom	Mom
Closed	Open	Latch	Latch	Mom	Mom
Open	Closed	Latch	Latch	Latch	Mom
Open	Open	Latch	Latch	Latch	Latch

Outputs

Outputs are digital CMOS/TTL (PIC Micro) with a series 220Ω protection resistor.
 Outputs are all normally high, active low. Each can sink/source 25/20mA.

Serial Data Output

The RDF1 has a serial data output. This outputs the serial number, button and battery status of the transmitter encoder. This data may be fed directly to a microcontroller or RS232 type driver circuit which may then be fed directly to a PC serial port. Serial data is output initially and again every ½ second whilst data is being received from the transmitter. i.e. this output is valid regardless of whether the Transmitter/Encoder has been learnt to the RDF1 or not. The serial data packet contains a learn bit to show if an encoder input is learnt.

Serial Data Format

Serial Data is sent every 1/2 second as a stream of 7 bytes at 9.6K baud. The serial data format is: 8 data bits with 1 stop bit, no parity.

Serial data is output from the Decoder chip whenever a valid data packet from a compatible RF Solutions transmitter/Encoder is received regardless of learn

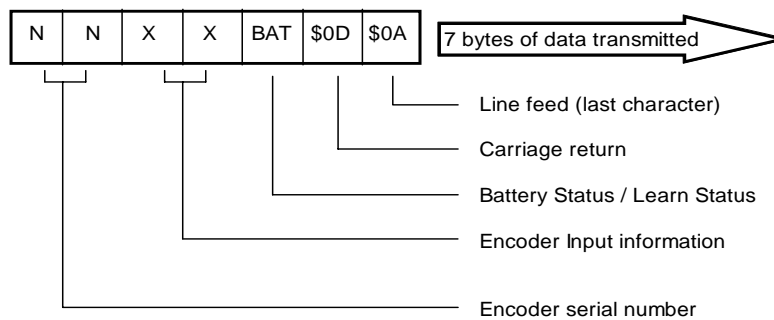

Output from Serial Data pin

Encoder Serial Number [NN]: made up of two 8-bit bytes where the most significant byte is transmitted first.

This provides a total of 65,536 possible serial numbers.

Example: 12AB (hexadecimal) or 0001 0010 1010 1011 (binary)

Encoder Input Information [XX]: made up of two 8-bit bytes.

The high order byte is sent first representing inputs 16 down to 9 where the MSb is input 16 and the LSb is input 9.

The low order byte is sent next representing inputs 8 down to 1 where the MSb is input 8 and the LSb is input 1.

A bit at state 1 represents an encoder input as active.

Using this method inputs can be multiplexed giving maximum versatility.

Example: 00000000 00001000 - Shows input 4 active.
 00000001 00000000 – Shows input 9 active
 10000001 00000001 – Shows inputs 16, 9 and 1 active

Status [STAT]: The status byte is made up of an 8-bit byte as follows:

<i>BIT</i>	<i>Description</i>	<i>Details</i>
Bit-7 down to 2	Reserved	For future usage
Bit 1	Learn status	1 = encoder has been learnt
Bit 0	Battery status	0 = encoder battery is OK 1 = encoder battery is low

Example: 00000010 = encoder battery ok, encoder has been learnt

00000001 = encoder battery low, encoder has not been learnt

Carriage Return [CR] and Line feed [LF]

To mark the end of the serial packet ascii characters for carriage return (hex 0D) are sent followed by LF (hex 0A).

Custom Versions

Custom versions of the All transmitters and Receivers and chipsets are available to provide a bespoke remote chipset for OEM applications. Please contact our sales department for further information.

***NOTE: Serial Data output is common across the entire RF80n and RDF1 range, therefore up to 16 inputs states are sent. When using encoders with lower numbers of inputs the un-used bits are set to 0.**

Antenna Design

For most of applications a 17cm piece of wire is quite adequate for 433 MHz modules. The range achieved from the system is dependent on the choice and position of the antenna. The space around the antenna is as important as the antenna itself. The optimum position is to locate the antenna so that it protrudes directly out the top of the transmitter box. If this is not possible due to other design constraints, try to keep the antenna, and in particular, the 'HOT' end away from other metal in the system such as transformers, batteries and PCB tracks, especially ground planes.

For further information on Antenna design please see our full product catalogue.

Mechanical Details

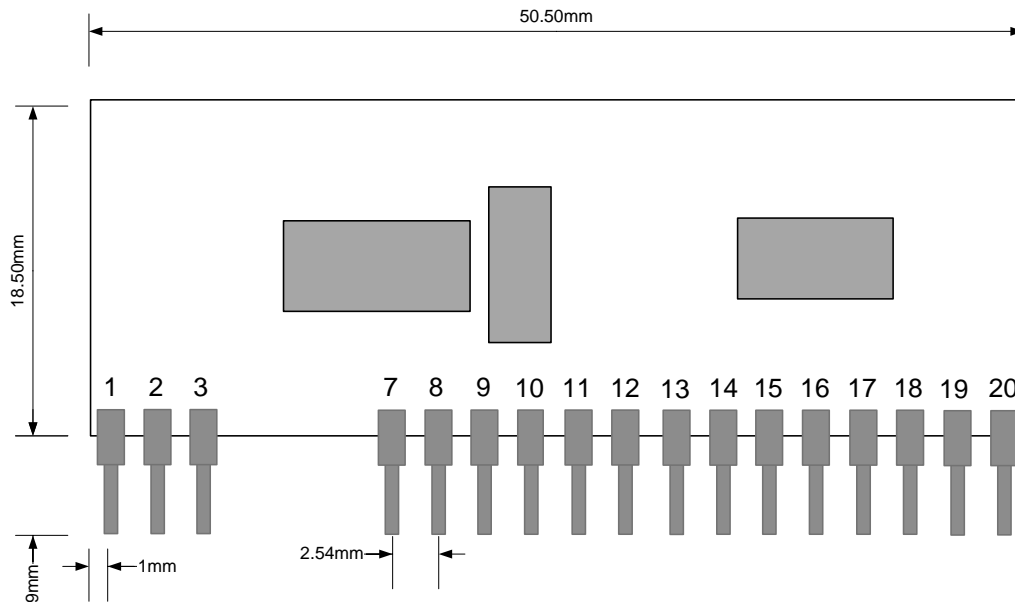

Absolute Maximum Ratings

Supply Voltage (+5Vcc to GND).....-0.3 to + 6 Volts.
 Storage Temperature.....-30 to +85° Celsius.
 Operating Temperature..... 0 to +70° Celsius.

Technical Specification

Ambient temperature = 25° Celsius.

Electrical Specification	Min	Typical	Max	Dimension	Note
Supply Voltage		TBC			
Supply Current		TBC			
Receiver Frequency		TBC			
Receiver Frequency		TBC			
Working Frequency (custom Frequencies Available)		TBC			
Data output voltage: (any data output)		TBC			
Logic Low		TBC			
Logic High		TBC			
Data output current: (any data output)		TBC			
Logic Low		TBC			
Logic High		TBC			
Turn on Time		TBC			
-3dB Bandwidth		TBC			
R.F Sensitivity (100% AM)		TBC			
Level of Emitted Spectrum		TBC			
EMC Compliance					

For more information or general enquiries, please call;

R. F. Solutions Ltd.,
Unit 21, Cliffe Industrial Estate,
South Street,
Lewes,
E Sussex, BN8 6JL. England.

Tel +44 (0)1273 898 000. Fax +44 (0)1273 480 661.

Email sales@rfsolutions.co.uk

<http://www.rfsolutions.co.uk>

RF Solutions is a member of the Low Power Radio Association.

Information contained in this document is believed to be accurate, however no representation or warranty is given and no liability is assumed by R.F. Solutions Ltd. with respect to the accuracy of such information. Use of R.F.Solutions as critical components in life support systems is not authorised except with express written approval from R.F.Solutions Ltd.