

„Schutzvermerk nach DIN 34 beachten“

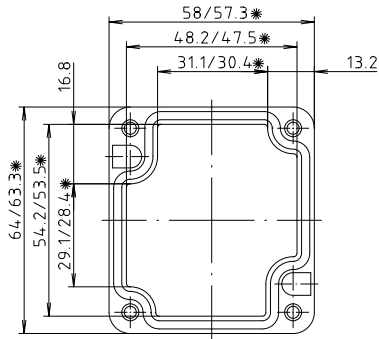

\* = Mass durch Formkonizität nach unten verringert.  
Freimass – Toleranz nach GTA 13/5 DIN 1688

Deckel

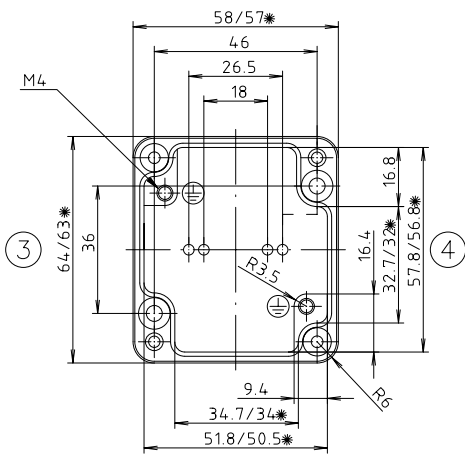
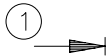

Unterteil



Zylinderschraube M4 x 20/7  
ähnl. DIN EN ISO 1207

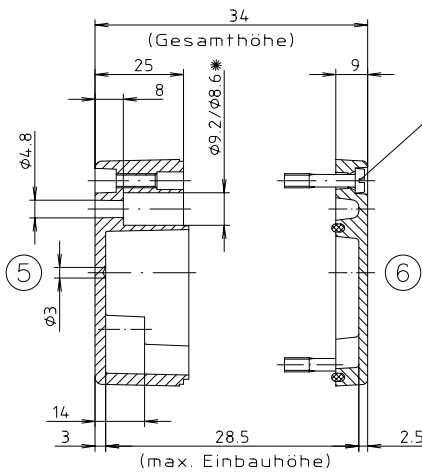

Konvertierung nicht zulässig!	
Maßstab: 1:1	
Zchn.Nr: 3K 101.048.02	
Artikel: A101 / 01.060603 Katalogzeichnung	
3587	
Ae.Nr:	Datum:
11.12.01	
DISK : 2 4 01 710	
Datum: 27.04.99 HR	

