

FRONT VIEW

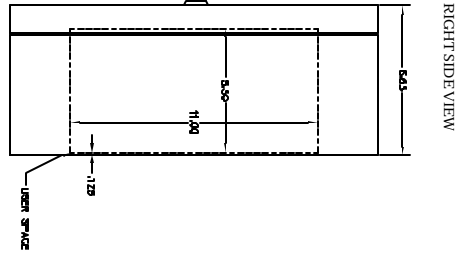

RIGHT SIDE VIEW

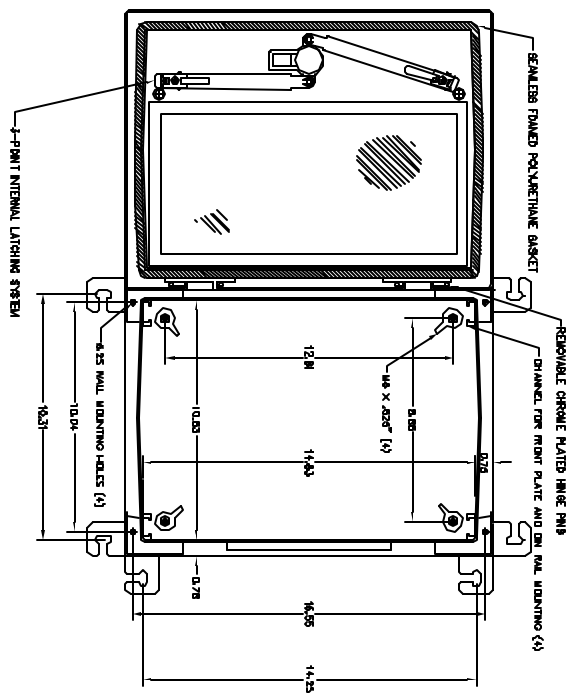

BASE  
FRONT VIEW WITH COVER OPEN 180°

END VIEW

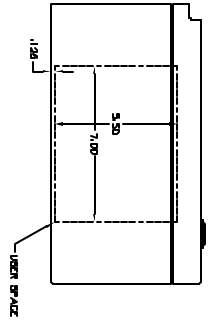

SECTION A-A

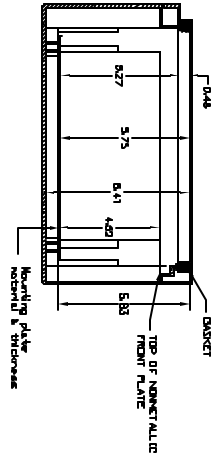

- NOTES:
- ENCLOSURE MATERIAL MADE OF BRICE GAL 7032) HOT MOLDED FIBERGLASS REINFORCED POLYESTER
  - UL LISTED PER STD. 508
  - CSA CERTIFIED PER STD. C222 NO. 94
  - NEHA RATED TYPE 3 3/4, 3S, 4, 4X, 1E AND 13.
  - IEC SP9 RATED UP TO 66-11, 3S, 4, 4X, 1E AND 13.
  - RESISTANT TO TEMPERATURES UP TO 150 DEG C.
  - SELF EXTINGUISHING AND HALOGEN FREE.
  - ACCESSORIES INCLUDE: BACK PANELS, HINGE PIN, POLYESTER FRONT PLATES, DIN RAIL MOUNTING SYSTEM, HINGE PIN, LOCKING HANDLES, AND VENTILATORS.
  - CABINETS ARE MAINTENANCE FREE AND CORROSION RESISTANT.

<p><b>VYNCKLER</b> POLYESTER SYSTEMS, INC.</p>		<p>VERSION 1.0  <b>ARIA SERIES</b>  <b>ENCLOSURE</b></p>	
<p>DESIGNED BY: [ ]          DRAWN BY: [ ]          CHECK BY: [ ]          DATE: [ ]</p>	<p>DATE: [ ]          TIME: [ ]          DRAWN BY: [ ]          CHECK BY: [ ]          DATE: [ ]</p>	<p>DATE: [ ]          TIME: [ ]          DRAWN BY: [ ]          CHECK BY: [ ]          DATE: [ ]</p>	<p>DATE: [ ]          TIME: [ ]          DRAWN BY: [ ]          CHECK BY: [ ]          DATE: [ ]</p>