

THIS DOCUMENT IS THE PROPERTY OF KEYSTONE ELECTRONICS CORP. AND SHALL NOT BE REPRODUCED, DISTRIBUTED OR USED AS A BASIS FOR MANUFACTURE WITHOUT PRIOR WRITTEN PERMISSION FROM KEYSTONE ELECTRONICS CORP.

MOUNTING PAD LAYOUT. REQUIRED SPACING FOR 'A' OR 'AA' BATTERIES

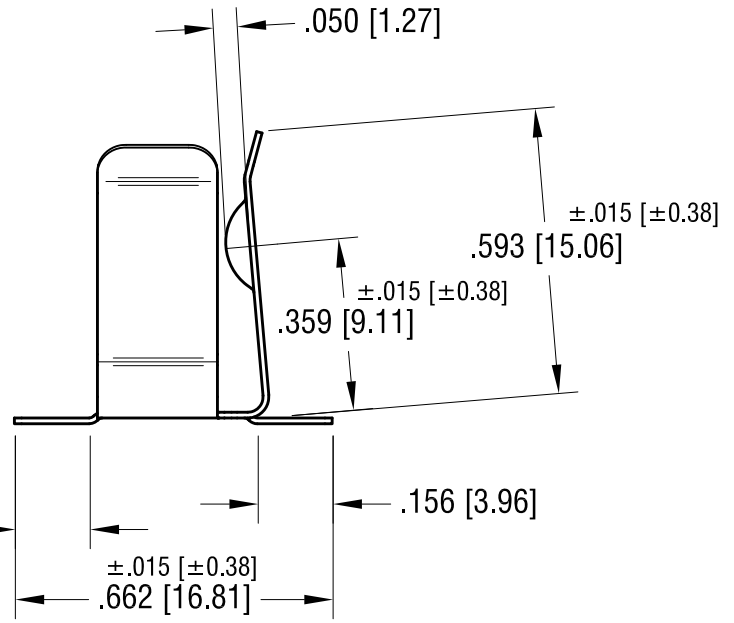
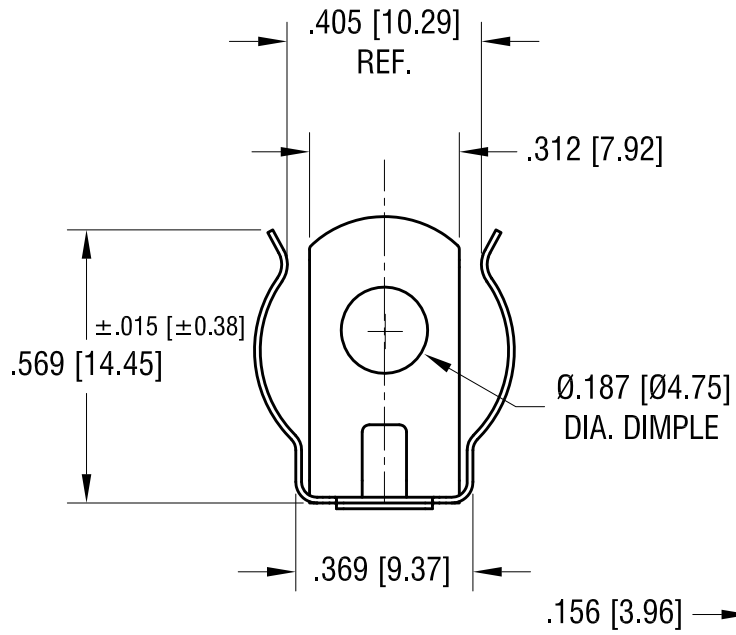
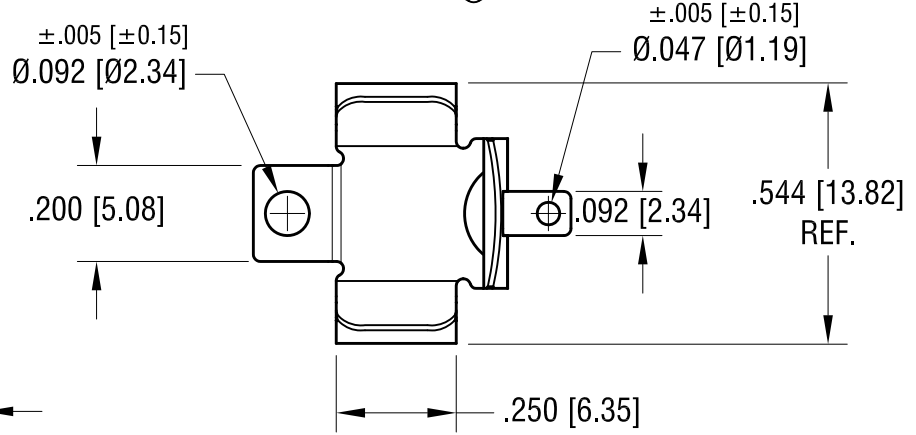
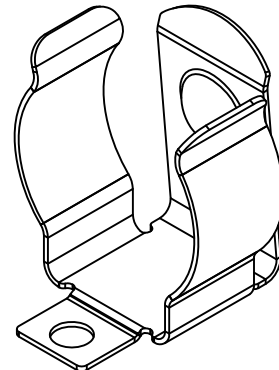
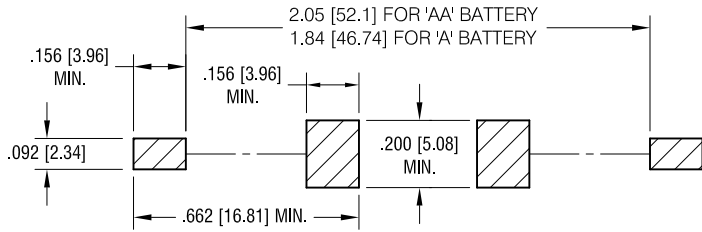

NOTE:
1. HEAT TREAT TO SPRING TEMPER.

10.20.09	CHANGE AS PER ECN 09-153	A
DATE	DESCRIPTION	REV.

KEYSTONE ELECTRONICS CORP.		
www.keyelco.com • ASTORIA, N.Y. 11105-2017 • Tel (718) 956-8900		
PART NAME 'A' & 'AA' BATTERY HOLDER		
MATERIAL .012 [.30] TH'K ANNEALED SPRING STEEL		
FINISH MATTE TIN PLATE	DRN BY NT	DATE 7.20.09
	APP'D	SCALE 2.5X
TOLERANCES INCH [MM] DECIMAL ±.010 [±0.25] ANGULAR ± 1° UNLESS OTHERWISE SPECIFIED	CODE C	DWG NO. 553