

THIS DOCUMENT IS THE PROPERTY OF KEYSTONE ELECTRONICS CORP. AND SHALL NOT BE REPRODUCED, DISTRIBUTED OR USED AS A BASIS FOR MANUFACTURE WITHOUT PRIOR WRITTEN PERMISSION FROM KEYSTONE ELECTRONICS CORP.

MOUNTING PAD LAYOUT

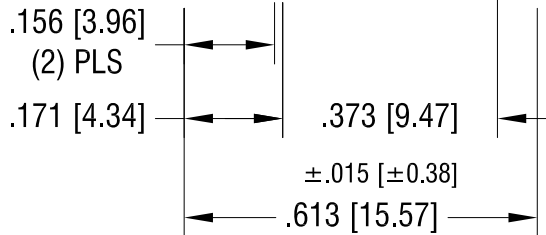
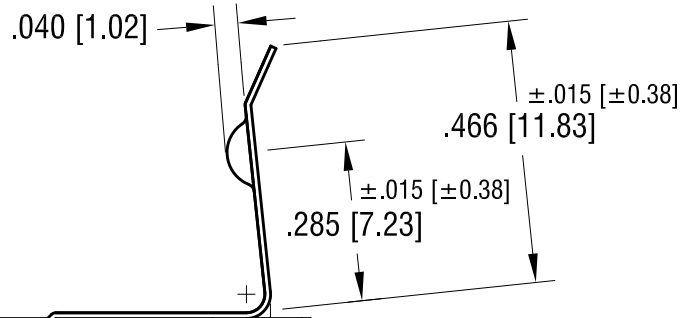
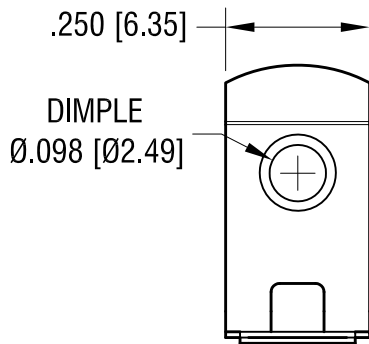
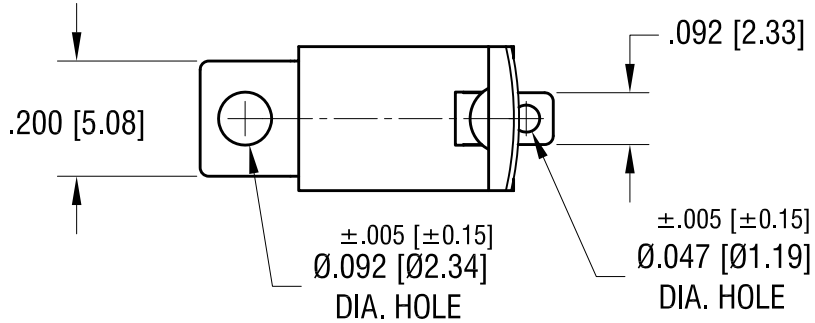
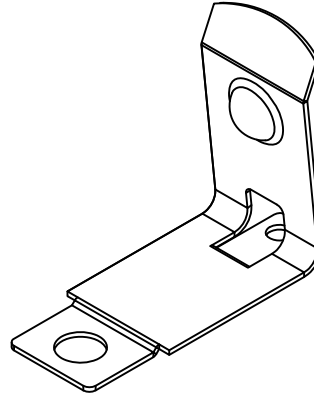
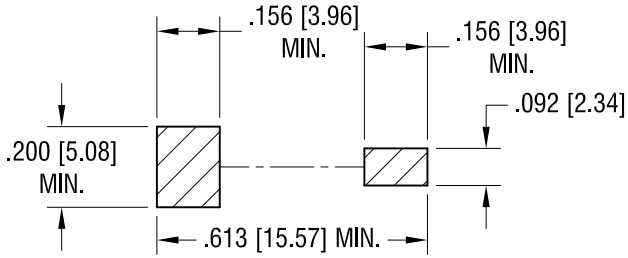

NOTE:

1. HEAT TREAT TO SPRING TEMPER.

KEYSTONE ELECTRONICS CORP.			
www.keyelco.com • ASTORIA, N.Y. 11105-2017 • Tel (718) 956-8900			
PART NAME		'AA' SMT BATTERY CLIP	
MATERIAL		.010 [0.25] TH'K ANNEALED SPRING STEEL	
FINISH	DRN BY	DATE	8.27.09
MATTE TIN PLATE	NT	APP'D	SCALE
			3X
TOLERANCES	INCH	[MM]	CODE
DECIMAL	± .010	[± 0.25]	C
ANGULAR	± 1°		DWG NO.
UNLESS OTHERWISE SPECIFIED			557

DATE	DESCRIPTION	REV.	
------	-------------	------	--