

THIS DOCUMENT IS THE PROPERTY OF
KEYSTONE ELECTRONICS CORP. AND
SHALL NOT BE REPRODUCED, DISTRIBUTED
OR USED AS A BASIS FOR MANUFACTURE
WITHOUT PRIOR WRITTEN PERMISSION
FROM KEYSTONE ELECTRONICS CORP.

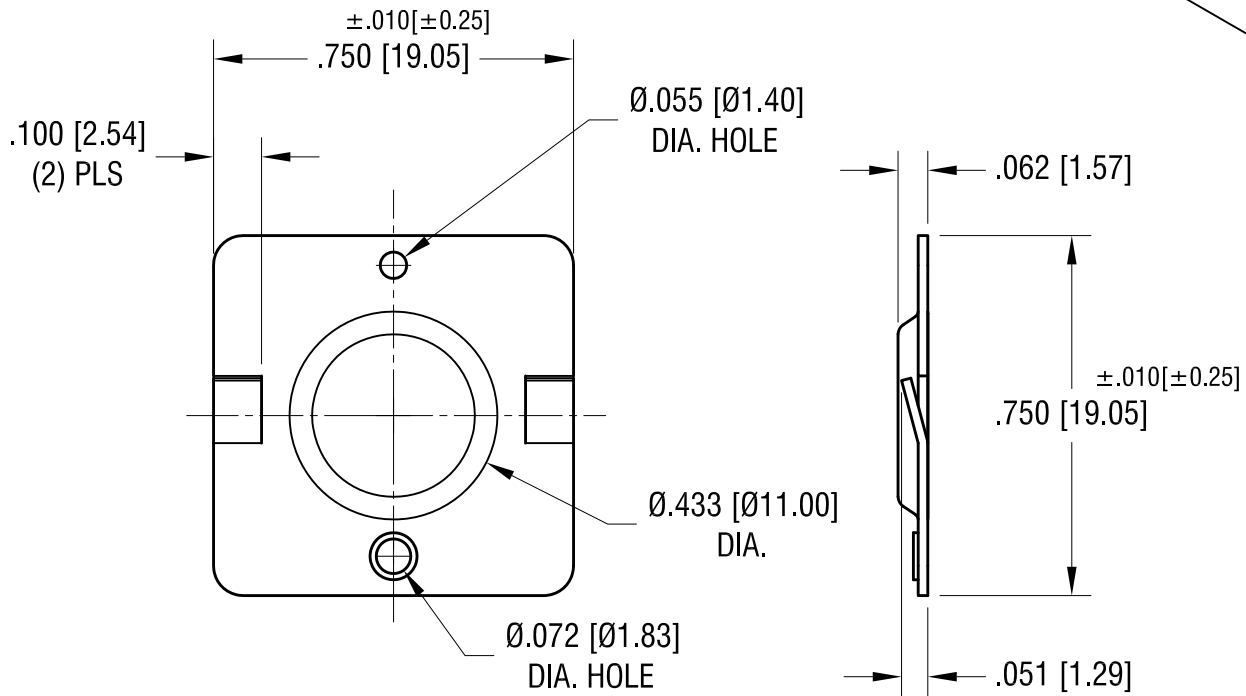
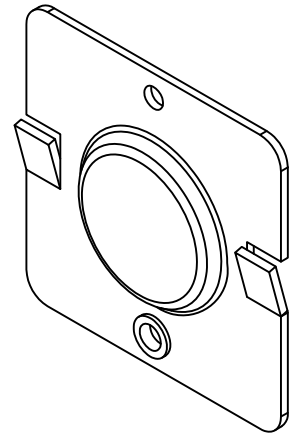

KEYSTONE ELECTRONICS CORP.			
www.keyelco.com • ASTORIA, N.Y. 11105-2017 • Tel (718) 956-8900			
PART NAME			
'C' CELL POSITIVE BATTERY CONTACT			
MATERIAL			
.020 [0.50] TH'K STEEL			
FINISH		DRN BY	DATE
NICKEL PLATE		NT	3.27.09
		APP'D	SCALE
			2.5X
TOLERANCES	INCH [MM]	CODE	DWG NO.
DECIMAL	± .005 [± 0.15]	C/M	5240
ANGULAR	± 1°		
UNLESS OTHERWISE SPECIFIED			

11.17.09	CHANGE AS PER ECN 09-169	A
DATE	DESCRIPTION	REV.