

Customer Information Sheet

DRAWING No: T1563F46 SHEET 2 OF 2 IF IN DOUBT - ASK © NOT TO SCALE THIRD ANGLE PROJECTION ALL DIMENSIONS IN mm

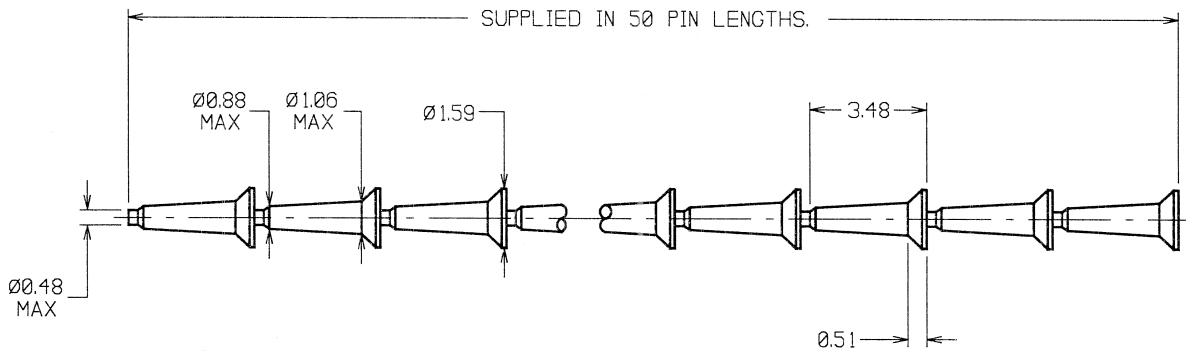

NOTES:

1. STRIPS ARE PACKED IN BOXES, 10 STRIPS PER BOX, (QUANTITY 500 PINS PER BOX).
2. USE WITH TRACK PIN INSERTION TOOL Z1002-00. AND INSTRUCTION SHEET IS-06.
3. THESE ITEMS ARE RoHS COMPLIANT.

MCP	1	15.02.06	9029
NAME	ISS.	DATE	C/NOTE
APPROVED: <i>MU</i>			
CHECKED: <i>KSBC</i>			
DRAWN: MARK G PLESTED			
CUSTOMER REF:			
ASSEMBLY DRG:			

HARWIN

HARWIN USA TEL: 603 893 5376 FAX: 603 893 5396 mts@harwin.com	HARWIN Europe (UK) TEL: 023 9231 4545 FAX: 023 9231 4590 mis@harwin.co.uk	HARWIN Asia TEL: +65 6 779 4909 FAX: +65 6 779 3868 mis@harwin.com.sg
--	--	--

THIS DRAWING AND ANY INFORMATION OR DESCRIPTIVE MATTER SET OUT HEREON ARE CONFIDENTIAL AND COPYRIGHT PROPERTY OF THE HARWIN GROUP AND MUST NOT BE DISCLOSED, LOANED, COPIED OR USED FOR MANUFACTURING, TENDERING OR FOR ANY OTHER PURPOSE WITHOUT THEIR WRITTEN PERMISSION

TOLERANCES
 X. - ±1mm
 X.X - ±0.25mm
 X.XX - ±0.10mm
 X.XXX - ±0.01mm
 ANGLES - ±5°
 UNLESS STATED

MATERIAL:
 BRASS CW614N M (CuZn39Pb3)
 TO BS EN 12164

FINISH: 100% TIN

S/AREA: mm²

TITLE: CONTINUOUS TRACK PIN.

DRAWING NUMBER: T1563F46

SHT 2 **OF** 2

Customer Information Sheet

DRAWING No: T1563F46K SHEET 2 OF 2 IF IN DOUBT - ASK © NOT TO SCALE THIRD ANGLE PROJECTION ALL DIMENSIONS IN mm

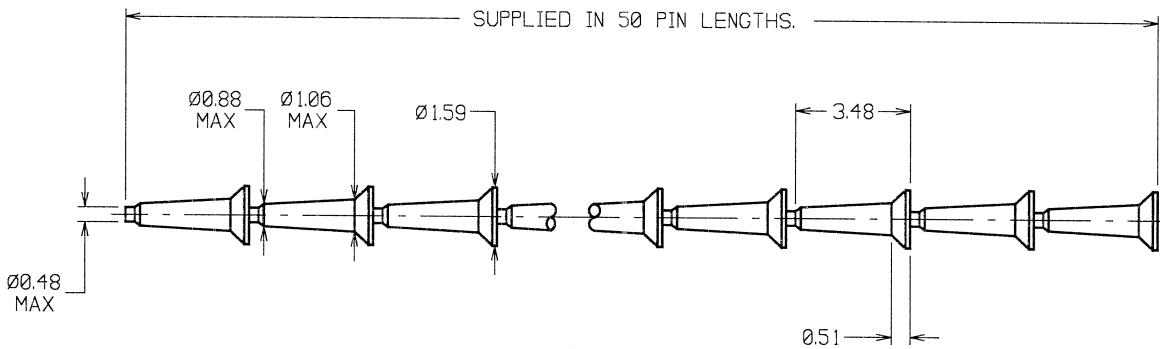

NOTES:

1. STRIPS ARE PACKED IN BOXES, 20 STRIPS PER BOX, (QUANTITY 1000 PINS PER BOX).
2. USE WITH TRACK PIN INSERTION TOOL Z1002-00. AND INSTRUCTION SHEET IS-06.
3. THESE ITEMS ARE RoHS COMPLIANT.

MCP	1	15.02.06	9029
NAME	ISS.	DATE	C/NOTE
APPROVED: <i>[Signature]</i>			
CHECKED: <i>[Signature]</i>			
DRAWN: MARK G PLESTED			
CUSTOMER REF.:			
ASSEMBLY DRG.:			

HARWIN

THIS DRAWING AND ANY INFORMATION OR DESCRIPTIVE MATTER SET OUT HEREON ARE CONFIDENTIAL AND COPYRIGHT PROPERTY OF THE HARWIN GROUP AND MUST NOT BE DISCLOSED, LOANED, COPIED OR USED FOR MANUFACTURING, TENDERING OR FOR ANY OTHER PURPOSE WITHOUT THEIR WRITTEN PERMISSION.

TOLERANCES
 X. - ±1mm
 X.X - ±0.25mm
 X.XX - ±0.10mm
 X.XXX - ±0.01mm
 ANGLES - ±5°
 UNLESS STATED

MATERIAL:
 BRASS CW614N M (CuZn39Pb3)
 TO BS EN 12164

FINISH: 100% TIN
S/AREA: mm²

TITLE:
 CONTINUOUS TRACK PIN.

DRAWING NUMBER:
 T1563F46K

SHT
 2
 OF
 2

HARWIN USA TEL: 603 893 5376 FAX: 603 893 5396 mis@harwin.com	HARWIN Europe (UK) TEL: 023 9231 4545 FAX: 023 9231 4590 mis@harwin.co.uk	HARWIN Asia TEL: +65 6 779 4909 FAX: +65 6 779 3868 mis@harwin.com.sg
---	---	---