

Setting Up the Evaluation Board for the ADCLK950

PACKAGE LIST

Evaluation board with ADCLK950 component installed

Applicable documents (schematic, layout)

GENERAL DESCRIPTION

This user guide describes how to set up and use the evaluation board for the [ADCLK950](#). The ADCLK950 data sheet should be used in conjunction with this user guide.

The data sheet contains full technical details about the specifications and operation of this device.

The ADCLK950 is a very high performance clock fanout buffer. The evaluation board is fabricated using a high quality Rogers dielectric material. Transmission line paths are kept as close to 50 Ω as possible.

DIGITAL PICTURE OF EVALUATION BOARD

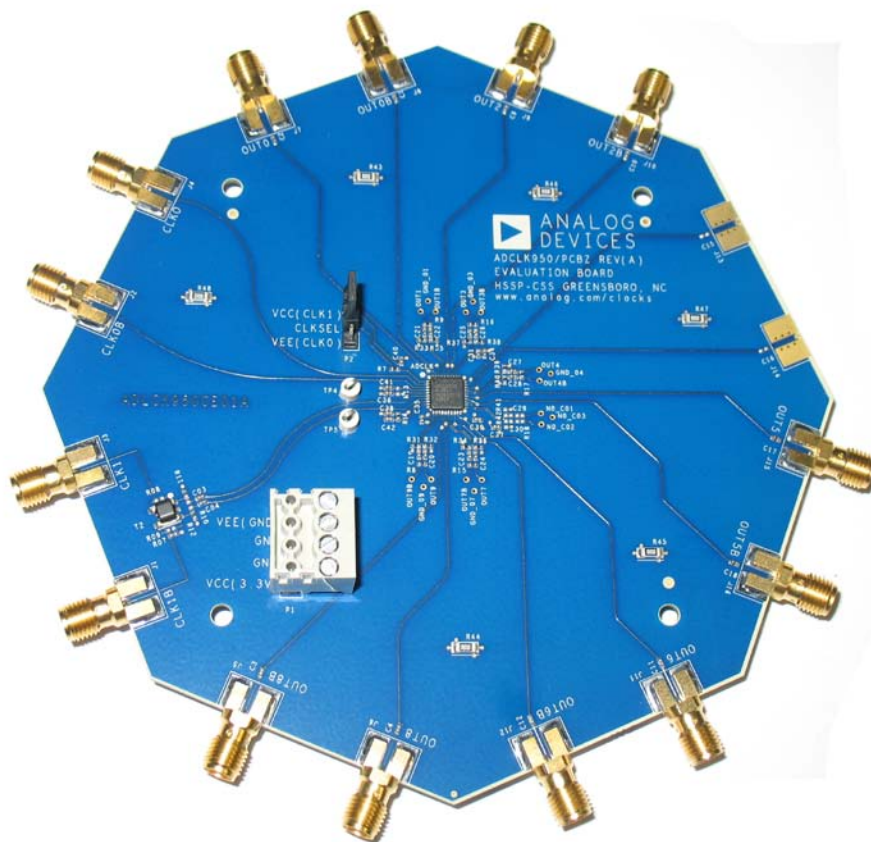

Figure 1. ADCLK950 Evaluation Board

08666-101

TABLE OF CONTENTS

Package List	1	Recommended Board Setup	3
General Description	1	Clock Outputs.....	4
Digital Picture of Evaluation Board	1	Evaluation Board Schematic and Artwork.....	5
Revision History	2	ESD Caution.....	8
Evaluation Board Hardware.....	3		

REVISION HISTORY

11/09—Revision 0: Initial Version

EVALUATION BOARD HARDWARE

RECOMMENDED BOARD SETUP

The recommended setup for the ADCLK950 evaluation board is shown in Figure 2. V_{CC} is set to 3.3 V and V_{EE} is set to GND. The CLKSEL jumper (P2) is provided to select the desired input configuration.

On the evaluation board, Input CLK0 and Input $\overline{\text{CLK0}}$ are set up for dc-coupled operation to the ADCLK950 via J2 and J4. This input configuration requires the user to provide the appropriate ac swing and common-mode voltage to both inputs. Refer to the ADCLK950 data sheet for input specifications.

CLK1 is set up to evaluate with a single-ended source via the balun on the evaluation board. In addition, series capacitors in the path provide ac-coupled inputs to the ADCLK950. The common-mode voltage for both inputs is provided by tying

V_{REF1} and V_{T1} together. This connection is made with R14 installed at the factory.

The range of the peak-to-peak input voltage swing at CLK1 is 0.2 V p-p to 1.7 V p-p. Note that output jitter performance is degraded by an input slew rate, as shown in the data sheet.

Table 1. Basic Equipment Required

Quantity	Description
1	Single power supply
1	Signal source
1	High bandwidth oscilloscope
1	High bandwidth differential probe (optional)
4	Matched high speed cables

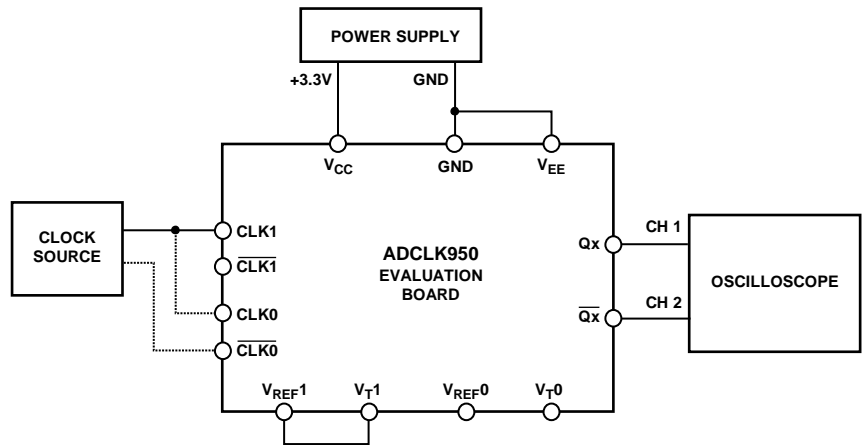

Figure 2. Recommended Setup for Device Evaluation

09865-002

CLOCK OUTPUTS

The ADCLK950 has 10 differential outputs. The five even-ordered differential clock outputs on the evaluation board are biased to GND via 200 Ω and ac-coupled to the SMAs. From the SMAs, use matched 50 Ω coaxial cables into the oscilloscope for evaluation. The five odd-ordered differential outputs on the evaluation board are not launched. Use a high bandwidth differential probe and oscilloscope close to the ADCLK950 device for evaluation. See the evaluation board schematic in Figure 4 for more details.

Table 2. Power Connections via P1

Label	ADCLK950
GND	Connect to GND
VCC	Connect to 3.3 V
VEE	Connect to GND

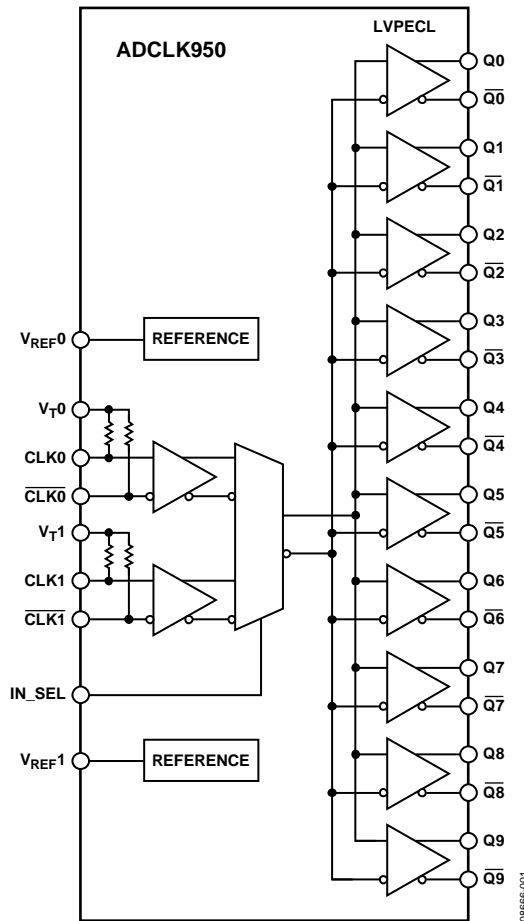

Figure 3. ADCLK950 1:10 Clock/Data Buffer Block Diagram

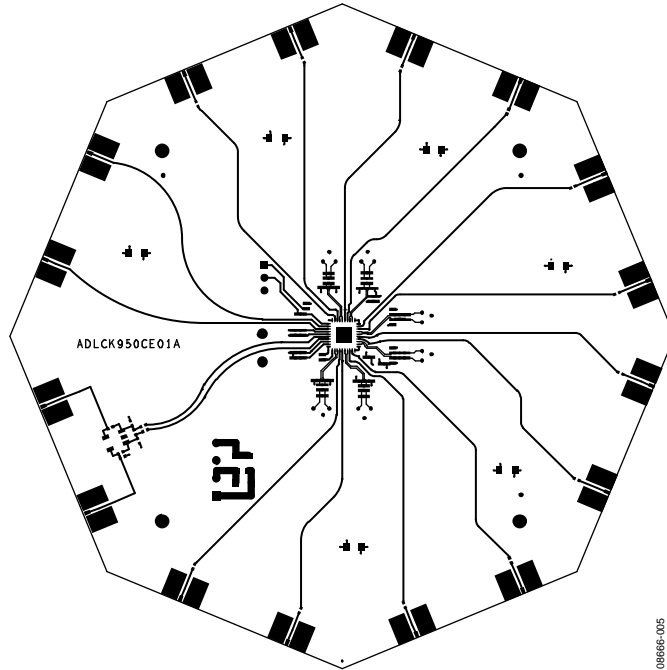

Figure 5. Top Trace Layer

08866-005

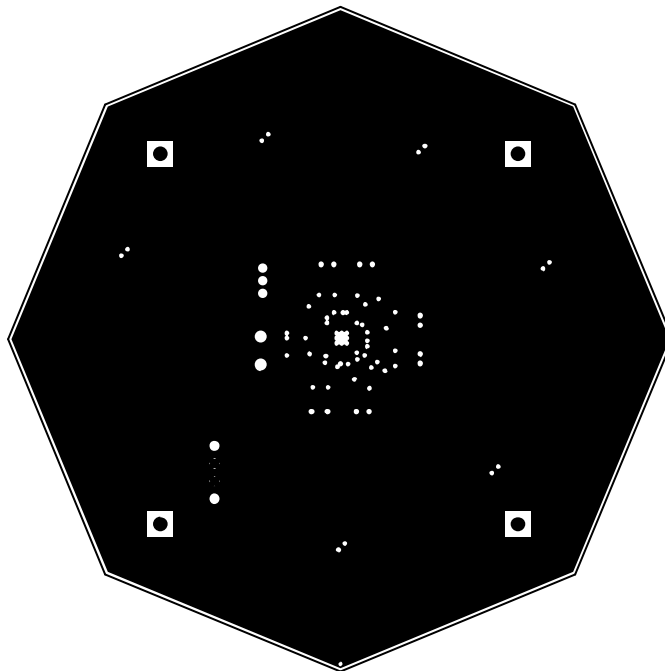

Figure 6. Ground Plane Layer

08866-006

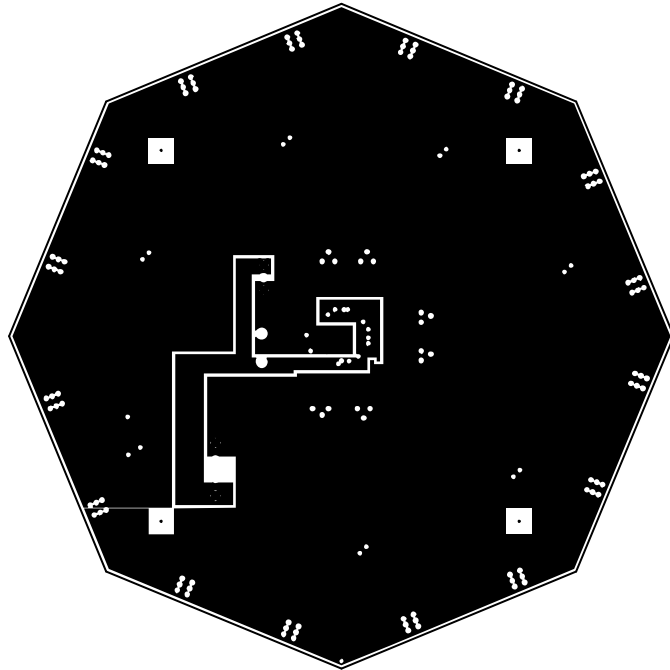

Figure 7. V_{CC} and V_{EE} Power Plane Layer

0886E-007

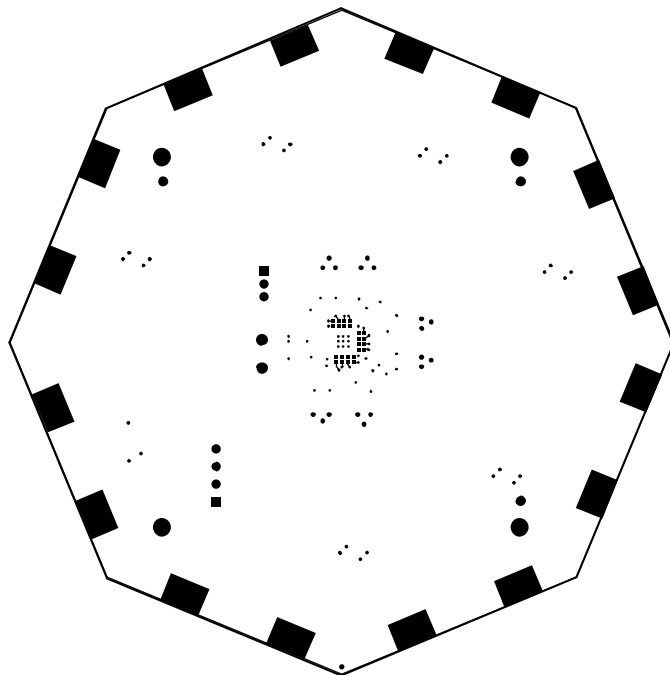

Figure 8. Bottom Trace Layer

0886E-008

NOTES

ESD CAUTION

**ESD (electrostatic discharge) sensitive device.**

Charged devices and circuit boards can discharge without detection. Although this product features patented or proprietary protection circuitry, damage may occur on devices subjected to high energy ESD. Therefore, proper ESD precautions should be taken to avoid performance degradation or loss of functionality.

Evaluation boards are only intended for device evaluation and not for production purposes. Evaluation boards are supplied "as is" and without warranties of any kind, express, implied, or statutory including, but not limited to, any implied warranty of merchantability or fitness for a particular purpose. No license is granted by implication or otherwise under any patents or other intellectual property by application or use of evaluation boards. Information furnished by Analog Devices is believed to be accurate and reliable. However, no responsibility is assumed by Analog Devices for its use, nor for any infringements of patents or other rights of third parties that may result from its use. Analog Devices reserves the right to change devices or specifications at any time without notice. Trademarks and registered trademarks are the property of their respective owners. Evaluation boards are not authorized to be used in life support devices or systems.

©2009 Analog Devices, Inc. All rights reserved. Trademarks and registered trademarks are the property of their respective owners.
UG08666-0-11/09(0)



www.analog.com