

LEDKIT-100 Lighting Design Kit

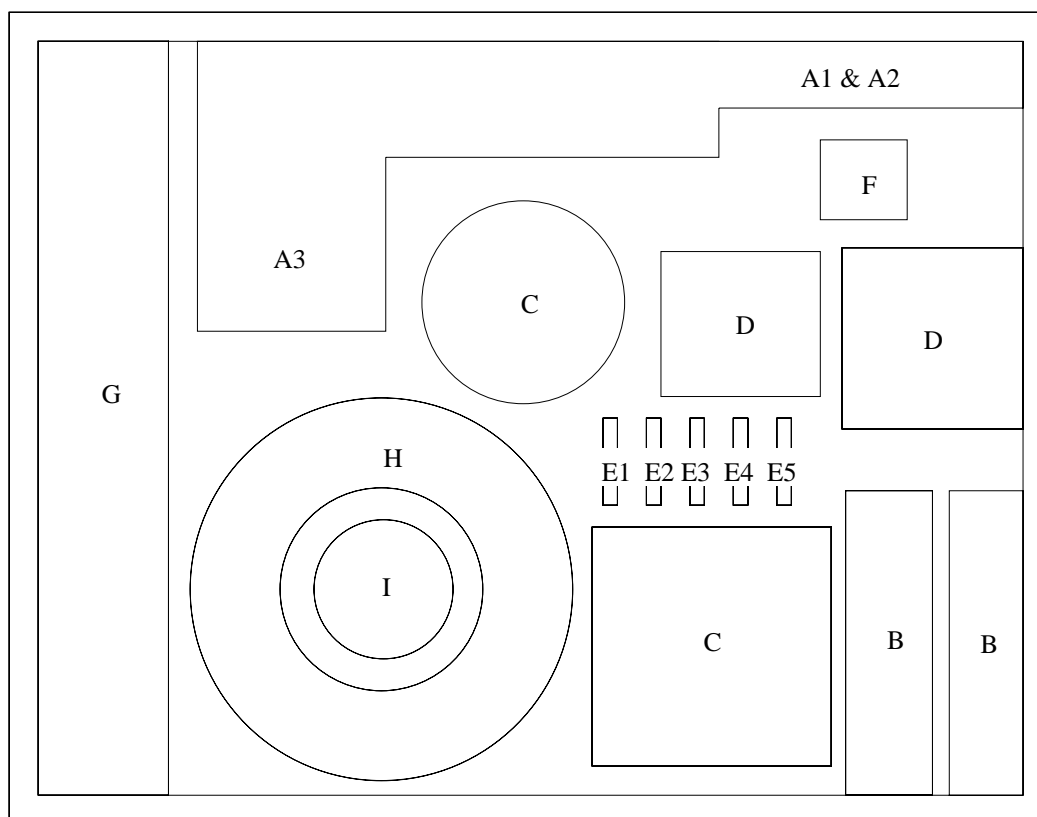

Area	Part #	Description	Page #
A1 A2 A3	LD350 LD700 LD1400	Power cube 350 mA with 110 VAC power cord. Power cube 700 mA with 110 VAC power cord. Power cube 1400 mA with 110 VAC power cord.	A23
B	OPA729	Linear 10/1 watt, LED—Power with LD700	A14
C	OPA730	Round Flood 12/1 watt, LED—Power with LD700	A15
D	OPA731	Square Flood 20/1 watt, LED—Power with LD1400	A16
E1 E2 E3 E4 E5	OPA733R OPA733Y OPA733G OPA733B OPA733W	Round Spot 1 watt, Red LED—Power with LD350 Round Spot 1 watt, Yellow LED—Power with LD350 Round Spot 1 watt, Green LED—Power with LD350 Round Spot 1 watt, Blue LED—Power with LD350 Round Spot 1 watt, White LED—Power with LD350	A17
F	OPA739	Square 3/1 watt, LED—Power with LD350	A18
G	OPA740	Linear with Lens 10/1 watt, LED—Power with LD700	A19
H	OPA741	Ring with Lens 12/1 watt, LED—Power with LD700	A20
I	OPA742	Round Spot with Lens 1 watt, LED—Power with LD350	A21



TT electronics subsidiaries reserves the right to make changes at any time in order to improve design and to supply the best product possible.

Table of Contents

PRODUCT DATA SHEETS—Visible Light Emitting Diodes (VLED)

OVSP_BCR4 Series (1 watt component)	A-1
OPA729 (10 watt Linear Plate)	A-14
OPA730 (12 watt Round Plate).	A-15
OPA731 (20 watt Square Plate)	A-16
OPA733 (1 watt Round Spot).	A-17
OPA739 (3 watt Square Plate)	A-18
OPA740 (10 watt Linear Plate with Lens)	A-19
OPA741 (12 watt Round Plate with Lens).	A-20
OPA742 (1 watt Round Spot with Lens).	A-21
LD350, LD700 & LD1400 (Power Sources)	A-23
APPLICATION NOTE	B-1

TT electronics subsidiaries reserves the right to make changes at any time in order to improve design and to supply the best product possible.

IRC Advanced Film Division — www.irctt.com
OPTEK Technology, Inc. — www.optekinc.com
Welwyn Components Limited — www.welwyn-tt.com

OPA729—10 Watt Light Bar on Anotherm Heat Spreader

OPA729_



OPA729_D

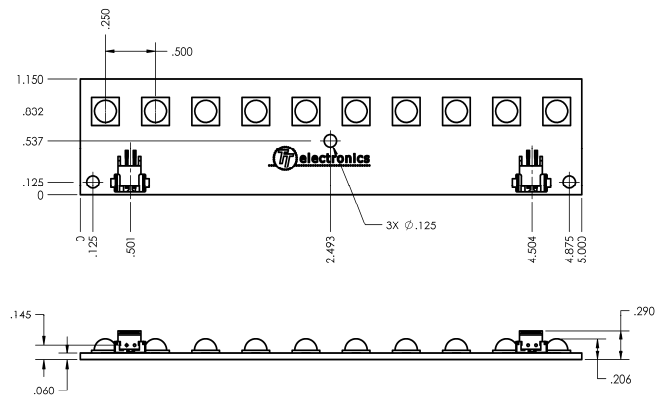
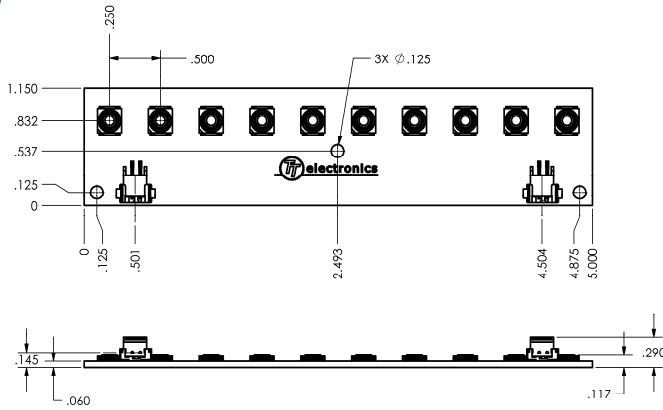

Electrical / Optical Characteristics: $T_A=25^\circ\text{C}$, $I_F=700\text{mA}$ [Green Dot Power Supply See page A-23]

Part Number	Typical Forward Voltage (V)	Luminous Flux (lm)	Beam Angle	Color
OPA729Y	12.5	350	120°	Yellow
OPA729B	18.0	90		Blue
OPA729G	18.0	480		Green
OPA729R	12.5	260		Red
OPA729W	18.0	480		White
OPA729YD	12.5	350	40°	Yellow
OPA729BD	18.0	90		Blue
OPA729GD	18.0	480		Green
OPA729RD	12.5	260		Red
OPA729WD	18.0	480	60°	White

TT electronics subsidiaries reserves the right to make changes at any time in order to improve design and to supply the best product possible.

OPA730—12 Watt Light Ring on Anotherm Heat Spreader

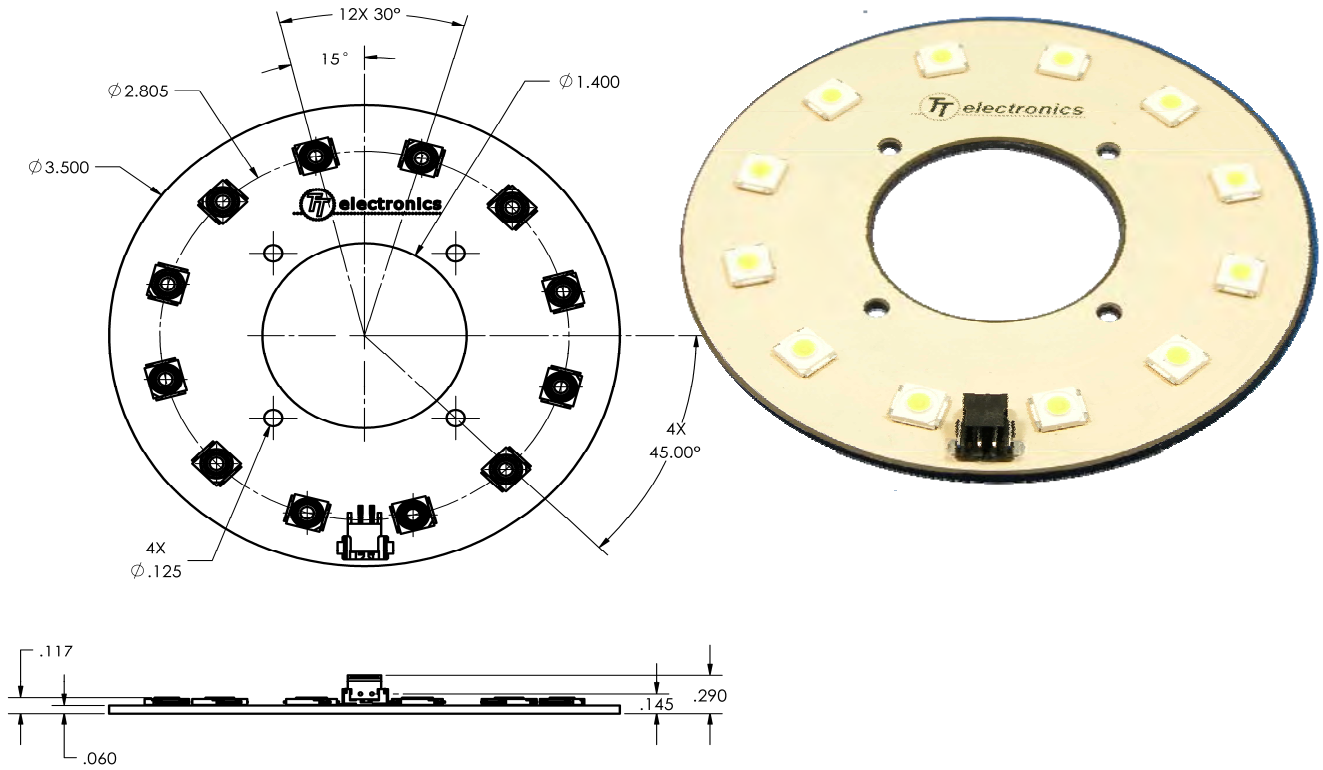

Electrical / Optical Characteristics: $T_A=25^\circ\text{C}$, $I_F=700\text{mA}$ [Green Dot Power Supply See page A-23]

Part Number	Typical Forward Voltage (V)	Luminous Flux (lm)	Beam Angle	Color
OPA730Y	15.0	420	120°	Yellow
OPA730B	21.6	108		Blue
OPA7309G	21.6	576		Green
OPA730R	15.0	312		Red
OPA730W	21.6	576		White
OPA730YD	15.0	420	40°	Yellow
OPA730BD	21.6	108		Blue
OPA730GD	21.6	576		Green
OPA730RD	15.0	312		Red
OPA730WD	21.6	576	60°	White

TT electronics subsidiaries reserves the right to make changes at any time in order to improve design and to supply the best product possible.

OPA731—20 Watt Light Flood on Anotherm Heat Spreader

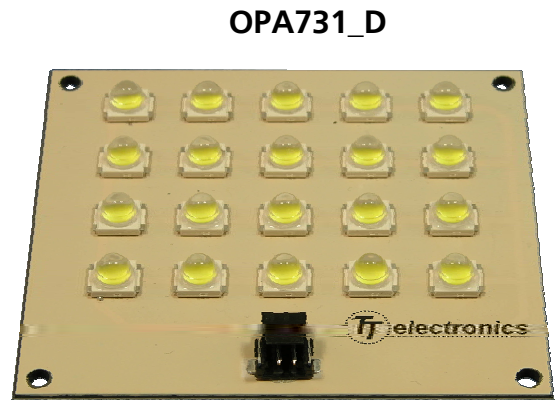
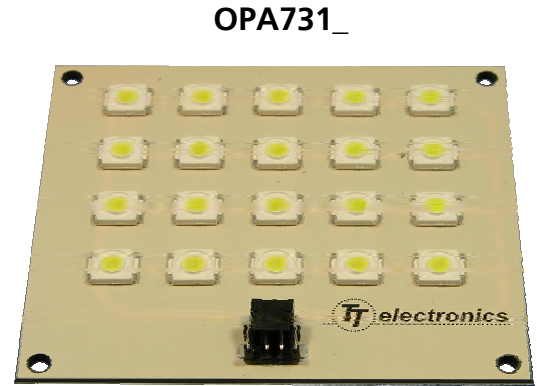
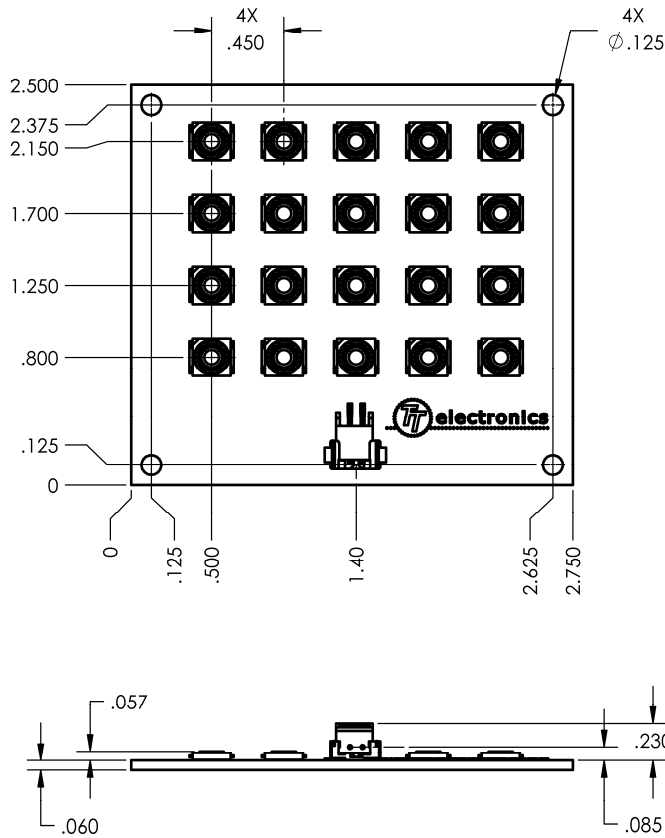

Electrical / Optical Characteristics: $T_A=25^\circ\text{C}$, $I_F=1.4\text{A}$ [Red Dot Power Supply See page A-23]

Part Number	Typical Forward Voltage (V)	Luminous Flux (lm)	Beam Angle	Color
OPA731Y	12.5	700	120°	Yellow
OPA731B	18.0	180		Blue
OPA731G	18.0	960		Green
OPA731R	12.5	520		Red
OPA731W	18.0	960		White
OPA731YD	12.5	700	40°	Yellow
OPA731BD	18.0	180		Blue
OPA731GD	18.0	960		Green
OPA731RD	12.5	520		Red
OPA731WD	18.0	960	60°	White

TT electronics subsidiaries reserves the right to make changes at any time in order to improve design and to supply the best product possible.

OPA733—1 Watt Light Spot on Anotherm Heat Spreader

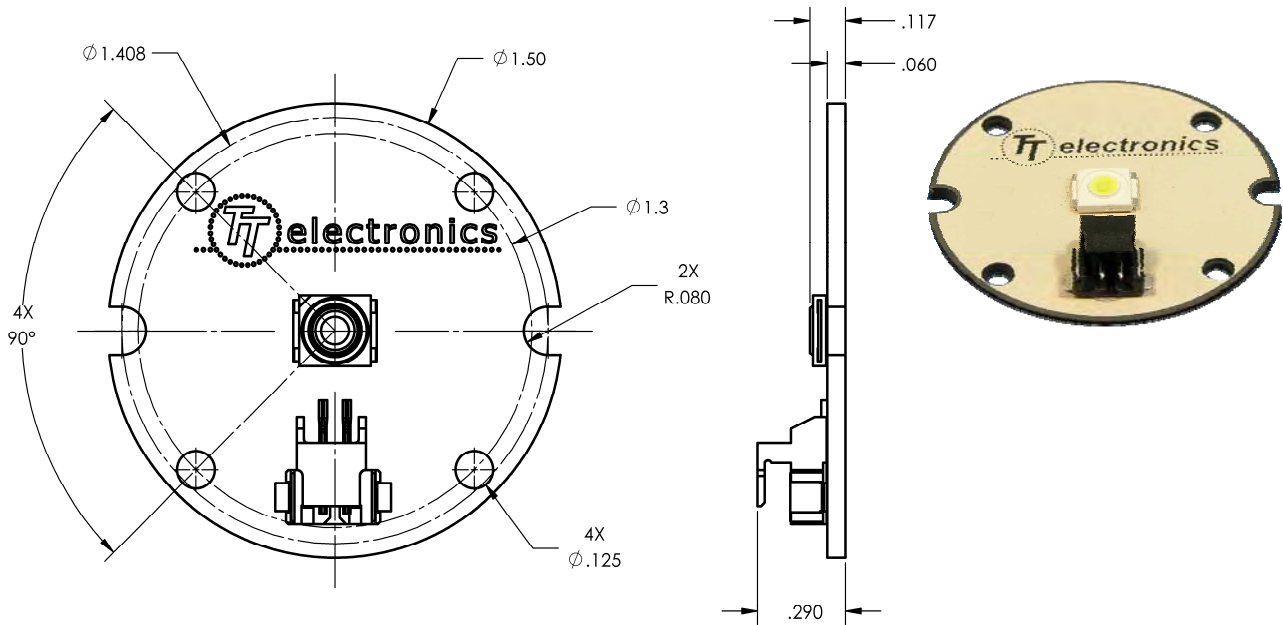

Electrical / Optical Characteristics: $T_A=25^\circ\text{C}$, $I_F=350\text{mA}$ [Blue Dot Power Supply See page A-23]

Part Number	Typical Forward Voltage (V)	Luminous Flux (lm)	Beam Angle	Color
OPA733Y	2.5	26	120°	Yellow
OPA733B	3.6	9		Blue
OPA733G	3.6	48		Green
OPA733R	2.5	35		Red
OPA733W	3.6	48		White
OPA733YD	2.5	26	40°	Yellow
OPA733BD	3.6	9		Blue
OPA733GD	3.6	48		Green
OPA733RD	2.5	35	60°	Red
OPA733WD	3.6	48		White

TT electronics subsidiaries reserves the right to make changes at any time in order to improve design and to supply the best product possible.

OPA739—3 Watt Light Bar on Anotherm Heat Spreader

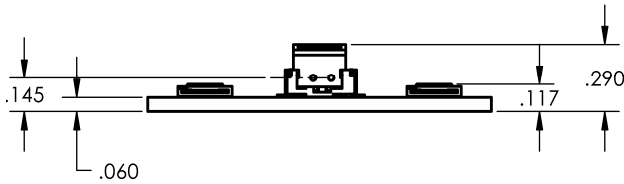
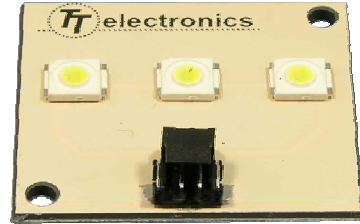
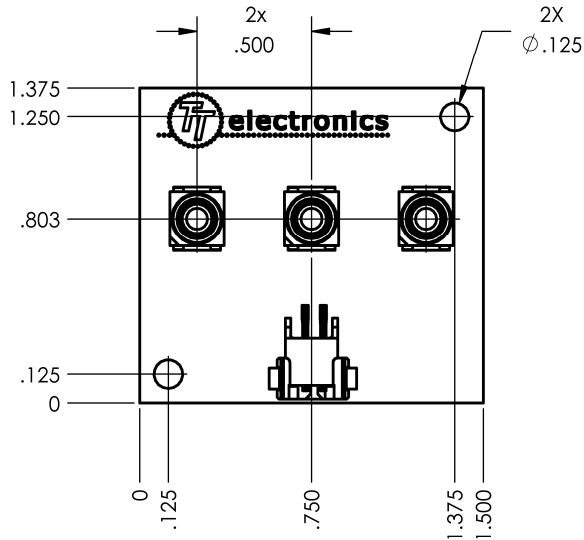

Electrical / Optical Characteristics: $T_A=25^\circ\text{C}$, $I_F=350\text{mA}$ [Blue Dot Power Supply See page A-23]

Part Number	Typical Forward Voltage (V)	Luminous Flux (lm)	Beam Angle	Color
OPA739Y	7.5	105	120°	Yellow
OPA739B	10.8	27		Blue
OPA739G	10.8	144		Green
OPA739R	7.5	78		Red
OPA739W	10.8	144		White
OPA739YD	7.5	105	40°	Yellow
OPA739BD	10.8	27		Blue
OPA739GD	10.8	144		Green
OPA739RD	7.5	78		Red
OPA739WD	10.8	144	60°	White

TT electronics subsidiaries reserves the right to make changes at any time in order to improve design and to supply the best product possible.

OPA740—10 Watt Light Bar on Anotherm Heat Spreader with Lens

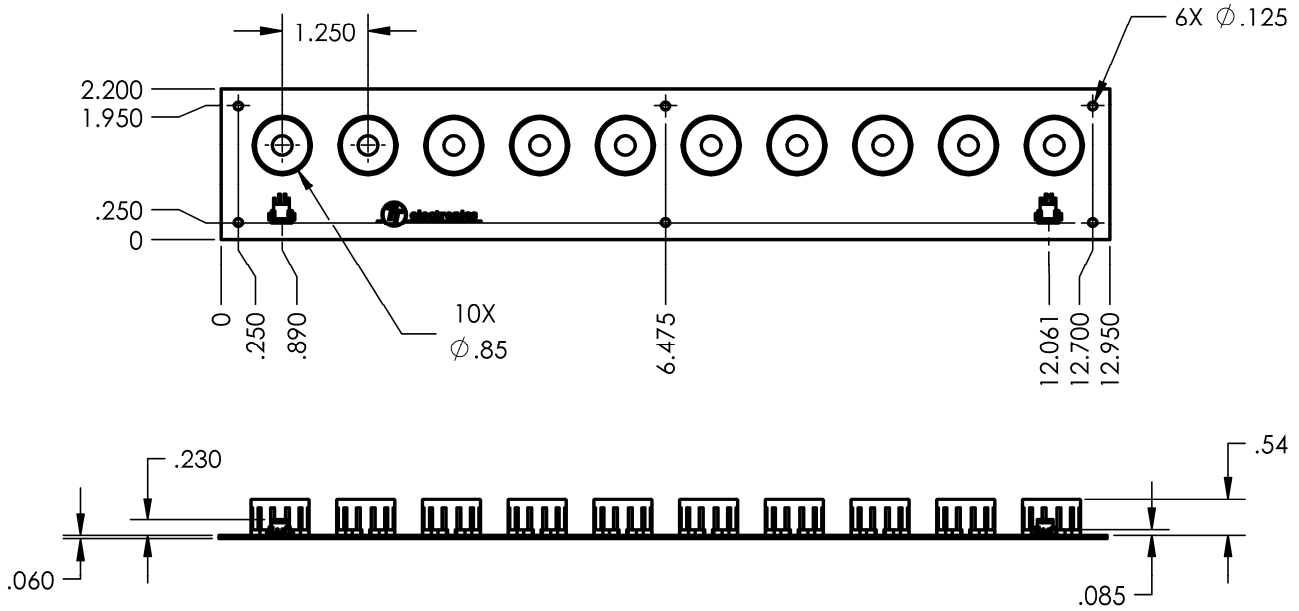

Electrical / Optical Characteristics: $T_A=25^\circ\text{C}$, $I_F=700\text{mA}$ [Green Dot Power Supply See page A-23]

Part Number	Typical Forward Voltage (V)	Luminous Flux (lm)	Beam Angle	Color
OPA740Y23	12.5	297	23°	Yellow
OPA740B23	18.0	76		Blue
OPA740G23	18.0	408		Green
OPA740R23	12.5	221		Red
OPA740W23	18.0	408		White

TT electronics subsidiaries reserves the right to make changes at any time in order to improve design and to supply the best product possible.

OPA741—12 Watt Light Ring on Anotherm Heat Spreader with Lens

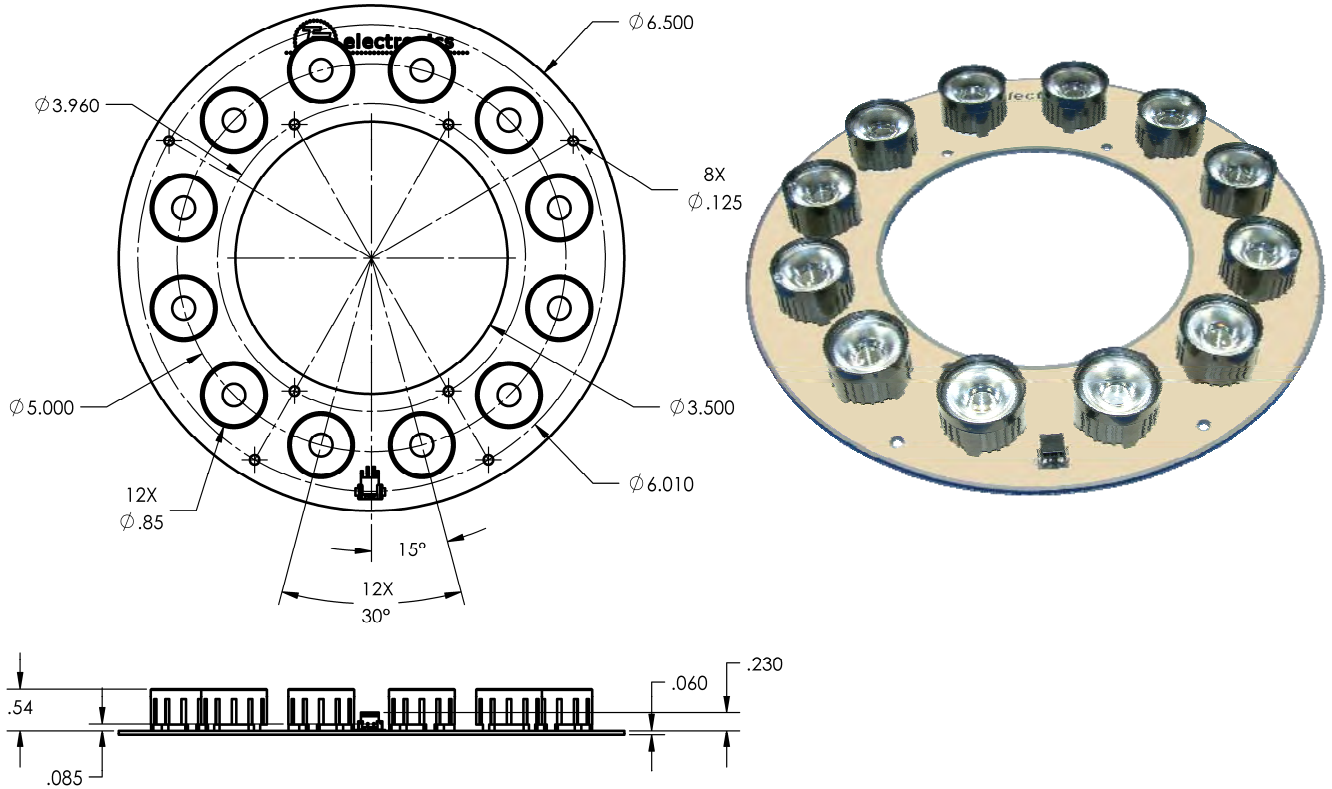

Electrical / Optical Characteristics: $T_A=25^{\circ}\text{C}$, $I_F=700\text{mA}$ [Green Dot Power Supply See page A-23]

Part Number	Typical Forward Voltage (V)	Luminous Flux (lm)	Beam Angle	Color
OPA741Y23	15.0	357	23°	Yellow
OPA741B23	21.6	92		Blue
OPA741G23	21.6	490		Green
OPA741R23	15.0	265		Red
OPA741W23	21.6	490		White

TT electronics subsidiaries reserves the right to make changes at any time in order to improve design and to supply the best product possible.

OPA742—1 Watt Light Spot on Anotherm Heat Spreader with Lens

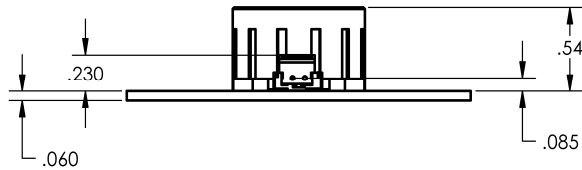
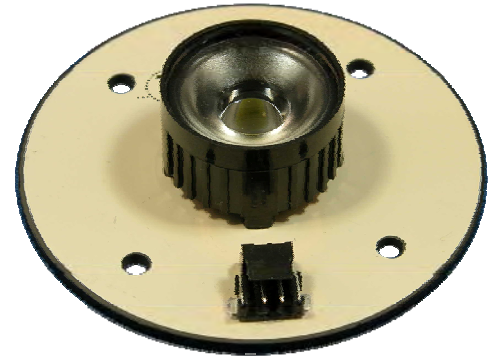
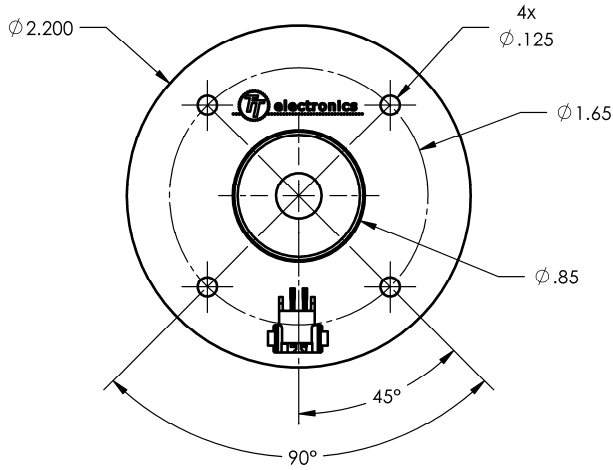

Electrical / Optical Characteristics: $T_A=25^\circ\text{C}$, $I_F=350\text{mA}$ [Blue Dot Power Supply See page A-23]

Part Number	Typical Forward Voltage (V)	Luminous Flux (lm)	Beam Angle	Color
OPA742Y23	2.5	22	23°	Yellow
OPA742B23	3.6	8		Blue
OPA742G23	3.6	41		Green
OPA742R23	2.5	30		Red
OPA742W23	3.6	41		White

TT electronics subsidiaries reserves the right to make changes at any time in order to improve design and to supply the best product possible.

Method to operate the drivers.

1. Connect the VLED assembly to the driver before applying power to the driver. If there is no load on the driver when it is powered, there will be 30 volts on the output. If you then connect the 30 volts to an assembly, it could over-stress the assembly.

2. Remove power from the driver before removing the LED assembly. If the VLED assembly is removed from the driver first, there will be 30 volts on the driver when you connect the next VLED assembly. The charge may remain on the output for a long time.

If the driver has been powered with no load on the output, the best method for removing the 30V charge is to connect the driver to the OPA730 ring VLED assembly. The more VLEDs in series, the less likely the no-load voltage charge will damage the assembly.



LD1400



LD350 & LD700

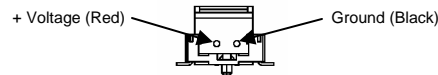
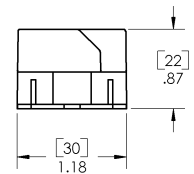
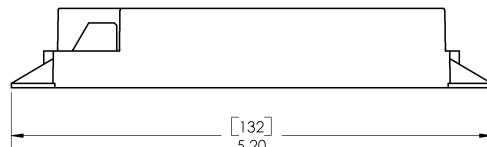
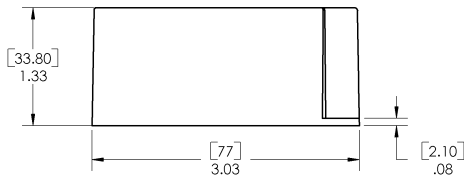
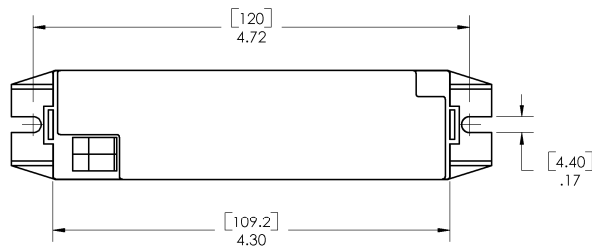
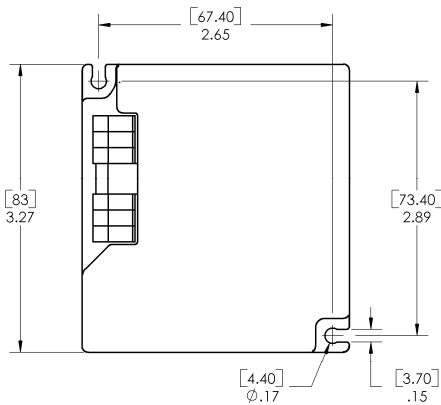

Part Number	Input Voltage	Input Power	Output Current	Output Voltage	Dot Color
LD350	120 VAC 60 Hz	15 Watts Max	350 mA	2.6 to 32.6 VDC	Blue
LD700	120 VAC 60 Hz	17 Watts Max	700 mA	7.8 to 24.6 VDC	Green
LD1400	120 VAC 60 Hz	51 Watts Max	1400 mA	7.8 to 24.6 VDC	Red

TT electronics subsidiaries reserves the right to make changes at any time in order to improve design and to supply the best product possible.

Insulated Aluminum Substrates

Thermal Solutions for Hi Brightness LED Applications

TT electronics is a leading designer and manufacturer of electronic components. As a result of our experience with power components, Anotherm[®] substrates were developed as an innovative method of addressing thermal problems.

Anotherm[®] substrates consist of a highly thermally conductive aluminum alloy substrate, with a special anodized aluminum oxide electrically insulating layer chemically grown on the aluminum core. This high temperature anodized layer offers good electrical isolation and excellent thermal transfer. Screen-printed, solderable conductors are then applied to the board and fired.

The result is a low cost, rigid circuit board with unsurpassed thermal efficiency. The completely inorganic construction results in substrate characteristics that maintain their properties even at high continuous operating temperatures. This process also allows the use of a wide range of substrate configurations including finned and multi-up arrays.

Hi brightness, high power LEDs benefit from Anotherm[®] substrates, allowing excellent heat transfer from the LED package, resulting in more light output and operation at higher power levels.

Substrate Characteristics

Material

The base material for the Anotherm[®] substrates is an aluminum alloy, either 3000 or 6000 series. This aluminum alloy has a high thermal conductivity and low cost. The thermal expansion coefficient of this material corresponds favorably with traditional P.C. board materials. Long term thermal shock testing confirms the ruggedness of the dielectric medium without delamination or degradation.

Dielectric Layer

The insulation system used on the Anotherm[®] substrate system is an anodically grown coating (similar to hard coat anodizing), that deposits a dense, thin film of aluminum oxide approximately 0.0017" thick (0.043mm) onto the aluminum surface. This inorganic dielectric layer gives a high quality insulation that is not affected by temperature or chemicals.

Anotherm substrates offer very high thermal conductivities with low thermal resistance from the die or chip to the substrate for power LED applications.

This results in:

- **Reduced operating temperature**
- **Higher operating power/density**
- **Improved reliability and reduced failures due to thermally induced problems.**

Conductors

Silver alloy conductors are screen printed and fixed onto the insulating dielectric layer. The standard conductor thickness is approximately 20 microns, although thicker conductors can be printed for higher current carrying capability.

Multiple Layers

Anotherm[®] substrates are ideal for applications requiring single layers on the front or backside of the board. When multiple layers or printed crossovers are required, polymer materials are used. As a result, the excellent thermal conductivity properties of Anotherm[®] substrates are lost in the additional layers. However, these traces can be used for carrying low power and control signals.

Solder Masks

Printed solder masking is available using a polymeric formulation.

Heatsinks

One interesting characteristic of this technology is the capability of printing solderable conductors directly onto heatsinks, thereby simplifying the assembly of power systems.

TT electronics subsidiaries reserves the right to make changes at any time in order to improve design and to supply the best product possible.