

Jewel®

- A. Insulating cap, ABS plastic. Jewel® logo molded into cap.
- B. 300 series stainless steel backplate (0.406mm thick). Manufacturing date code is stamped into stainless steel backplate.
- C. Small cam lock, allows material replacement. 300 series stainless steel.

- D. Large cam lock, allows size adjustment, maintains electrical continuity even when open. 300 series stainless steel.
- E. Floating cam lock* allows wide opening for easy adjustment and secures material down against base plate when closed.
- F. 4mm snap stud machined from 300 series stainless steel. Fits to 4mm spring loaded medical type socket. Coil cord disengages from snap with .45Kg - 2.27Kg of perpendicular force. Durable, providing long life well beyond that of sheet metal snaps.
- G. Knit elastic band material of light blue fiber; 22mm wide and 2.5mm thick. 50 strands of textured polyester, 36 strands of lycra spandex and 14 strands of silver plated Nylon 6 yarn. Outer surface of light blue fibers act as an insulator.
- H. The conductive silver plated Nylon 6 (see G) represents 13.5% of the material by weight. The 14 strands of conductive Nylon are randomly knit on the inner surface of the material and are electrically isolated from the outer surface (grey side).
- I. Underwriters Laboratory listing 90P1C.



DESCRIPTION	4mm	10mm
Band, sapphire clasp	60000	60001
Band, ruby clasp	60002	60003
Band, amethyst clasp	60004	60020
Band, topaz clasp	60006	60007
Band, emerald clasp	60008	60009
Sapphire clasp only	60010	60011
Ruby clasp only	60012	60013
Topaz clasp only	60014	60015
Emerald clasp only	60016	60017
Amethyst clasp only	60018	60019
Elastic replacement strip	60005	

Circumference:
 Min: 63.5mm
 Max: 330mm
 Width: 22mm

Designed to satisfy wrist strap requirements of IEC 61340-5.

Jewel® Lifetime Limited Warranty
 Charleswater expressly warrants that for a period of 1 year from the date of purchase, Charleswater Jewel® Wrist Straps and Coil Cords will be free of defects in material (parts) and workmanship (labor). In addition, normal use will not cause Coil Cord resistor strain relief connection or Wrist Band 4 mm snap stud to wear sufficiently to open path-to-ground circuit. Within the lifetime warranty period, a credit for purchase of replacement Charleswater Jewel® products, or, at Charleswater's option, the Charleswater Jewel® product will be repaired or replaced free of charge. If product credit is issued, the amount will be calculated based upon the original invoice purchase price.

See drawing 60260 for coil cord specifications.

Made in U.S.A.
 *U.S. Patent No. 4,662,695



JEWEL® WRISTBAND, ELASTIC, ADJUSTABLE

CONDUCTIVE PRODUCTS LTD.
 UNIT 17, MILLBROOK BUSINESS PARK, SYBRON WAY
 CROWBOROUGH, EAST SUSSEX TN6 3JZ UNITED KINGDOM
 PHONE: 00 44 (0) 1892-665313, FAX: 00 44 (0) 1892-668838
 INTERNET: www.charleswater.co.uk

Drawing Number
60000.E

DATE:
06/03

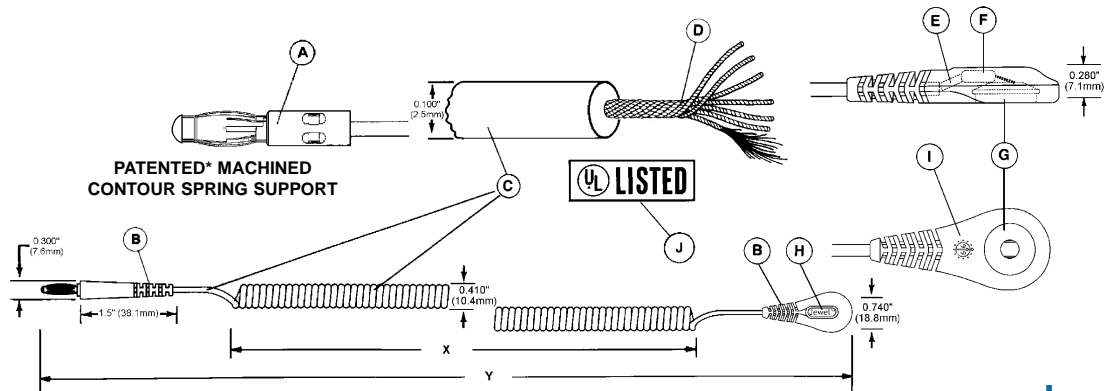

Jewel®

- A. Barrel type banana plug with **machined contour spring support***. Crimped uniformly from 4 sides for maximum strength. Fits industry standard banana jack $\geq 3.99\text{mm}$.
- B. Thermoplastic elastomer strain relief molded on. Flex life average $>27,500,000$ cycles (ESD S1.1). Break load average 13.5 Kg.
- C. Rapid retraction coil cord compresses length with resulting benefit of less tangling and dragging along work surface. Break load average 13.5 Kg. Various colored polyurethane wire insulation.
- D. Single T-2940 tinsel conductor. Consisting of 7 strands of polyester wrapped with copper. High flex life. Equivalent is 29 gauge (cir mil and/or Ohms).
- E. Autosplice brass crimp secures conductors to resistor lead and provides stress relief for resistor.
- F. One megohm $\pm 5\%$, 1/4 watt, series resistor limits current for operator safety.

- G. Spring loaded 4mm medical snap socket. Spring separation 3.18 mm - 4.19 mm*. Provides .45 Kg - 2.27 Kg breakaway from 4.06 mm snap stud (ESD S1.1). Compatible with most major brands.
 - H. Jewel® logo moulded in compliance with ESD S1.1.
 - I. Date coded with date of manufacture.
- Designed to satisfy wrist cord requirements of IEC 61340-5.

Jewel® Lifetime Limited Warranty

Charleswater expressly warrants that, for a period of 1 year from the date of purchase, Charleswater Jewel® Wrist Straps and Coil Cords will be free of defects in material (parts) and workmanship (labor). In addition, normal use will not cause Coil Cord resistor strain relief connection or Wrist Band 4 mm snap stud to wear sufficiently to open path-to-ground circuit. Within the lifetime warranty period, a credit for purchase of replacement Charleswater Jewel® products, or at Charleswater's option, the Charleswater Jewel® product will be repaired or replaced free of charge. If product credit is issued, the amount will be calculated based upon the original invoice purchase price.

SOCKET SIZE
Colour Termination Length* Resistor 4mm 10mm

Colour	Termination	Length*	Resistor	4mm	10mm
Sapphire	Banana	1.8m	1 x 1	60260	60261
Ruby	Banana	1.8m	1 x 1	60262	60263
Topaz	Banana	1.8m	1 x 1	60264	60265
Emerald	Banana	1.8m	1 x 1	60266	60267
Amethyst	Banana	1.8m	1 x 1	60268	60269

See drawing 60000 for wristband specifications.

*U.S. Patent 5951337

CHARLESWATER

JEWEL® GROUND CORD, WRIST STRAP, RAPID RETRACTION, COILED

CHARLESWATER LTD.
UNIT 17, MILLBROOK BUSINESS PARK, SYBRON WAY
CROWBOROUGH, EAST SUSSEX TN6 3JZ UNITED KINGDOM
PHONE: 00 44 (0) 1892-665313, FAX: 00 44 (0) 1892-668838
INTERNET: www.charleswater.co.uk

Drawing Number
60260.E

DATE:
06/03