

459-951 | + 459-939

ITW Electronic Packaging

1 of 3

## CONTROLS FOR ANTISTATIC TUBE

The standard used by ITW for testing antistatic tubes is the American National Standard ANSI/EIA-541-1988. Packaging material standards for ESD sensitive items.

### CONDITION CONTROLS

The machine used is an ETS 405 D Static Decay Meter  
Humidity control chamber

- The tubes are conditioned for 48 hours in a control chamber at 12% RH, which is more stringent than EIA 541 requirements of 15% RH.
- A static decay test on the tube is carried out by putting a surface charge of 5000 volts on the tube which should dissipate in less than 2s. ITW product averages 0.5 s. decay time.

The same test is made 3 times on the positive side and negative. The results are within 0.02 seconds to pass the test.

- Decay results of each daily production are recorded and are available on request.

### RESISTIVITY CONTROL

The machine is an ETS 806  
Surface resistivity meter

- The technical specification for anti-static tubes is  $>1*10e6$  and  $<1*10e12$
- ITW average products  $1*10e9$

### ANTISTATIC SOLUTION CONTROL

- The antistatic solution is tested once a day for conductivity and alcohol content.

### PRODUCTION CONTROL

- Hourly inspection
- Samples of each batch are kept on the shelf for 6 months.

2 of 3

PRINT ANTISTATIC IN BLUE

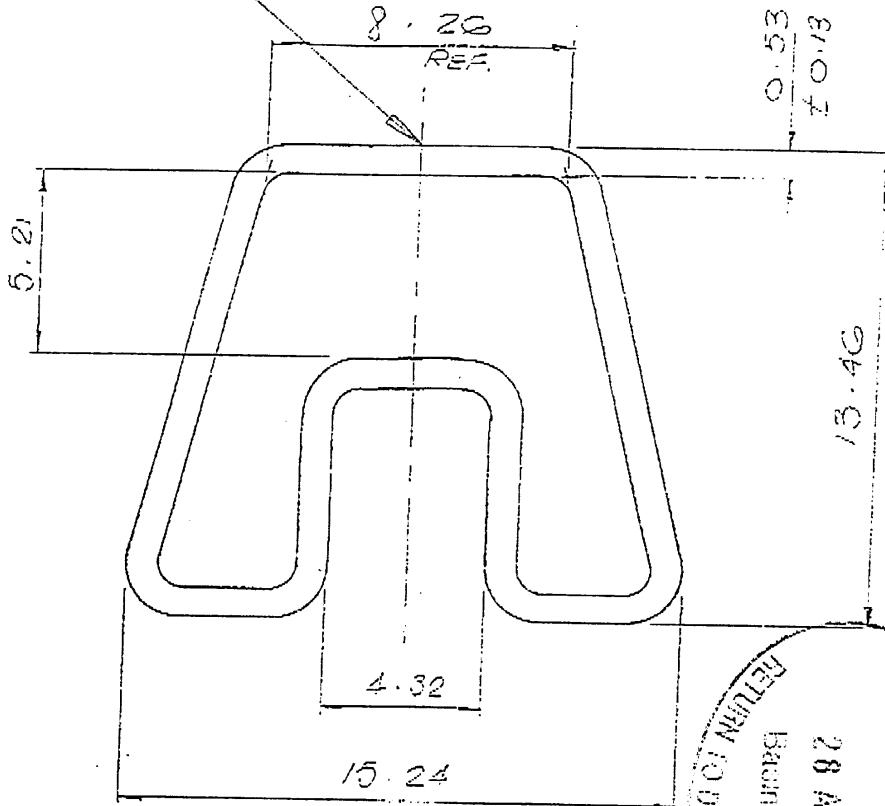

IF THIS STAMP IS  
NOT IN COLOUR  
THEN THIS IS AN  
ORIGINAL COPY

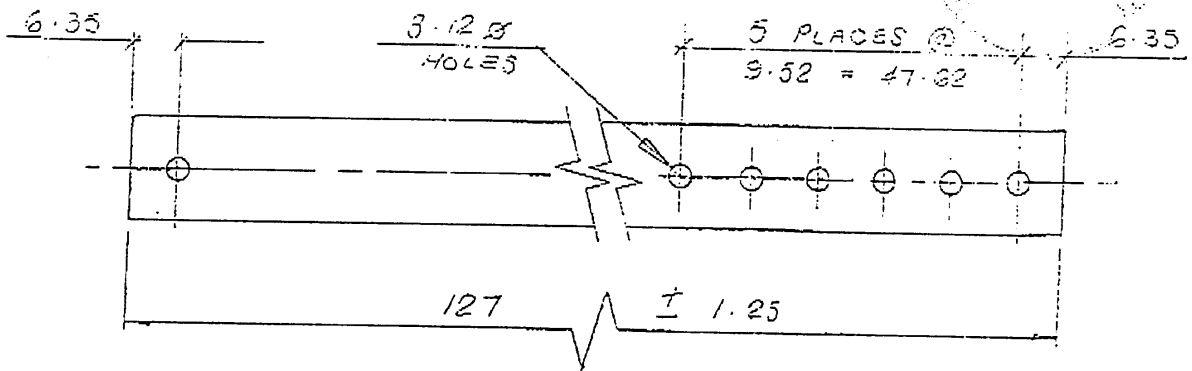
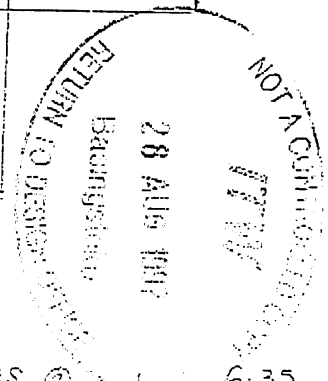

ALL UNSPECIFIED TOLERANCES ANGLES ± 1° 0.0 ± 0.50 0.00 ± 0.25 0.000 ± 0.10

REVISIONS

Issue No. / Colour

Date 21.9.89

EXTRUDED PRODUCTS  
A DIVISION OF ICI LIMITED  
WEST HALL INDUSTRIAL ESTATE/GRAFTON WAY  
WASINGTON, HANTS RG22 0HY  
TEL: (0256) 436773 Tlx: 85908V  
TELEFAX: (0256) 464777

P.R. No. 8804	Des. Tx	Dm. Vo	Date 21.9.89	Chk.	Area Sq. mms.	Wt. Kg./M	Matl. CL. PVC.	NAME 300 DIP
SCALE 5:1 1:1	ALL DIMS IN mms.	TOOL REF.		PART No. 4 28 40805 23				

3 of 3

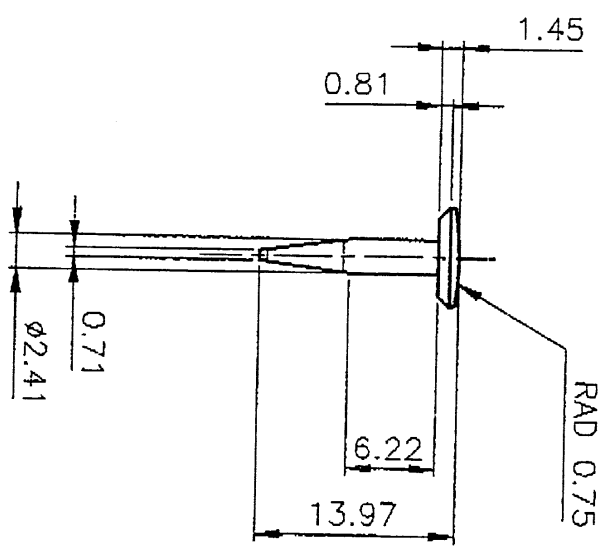
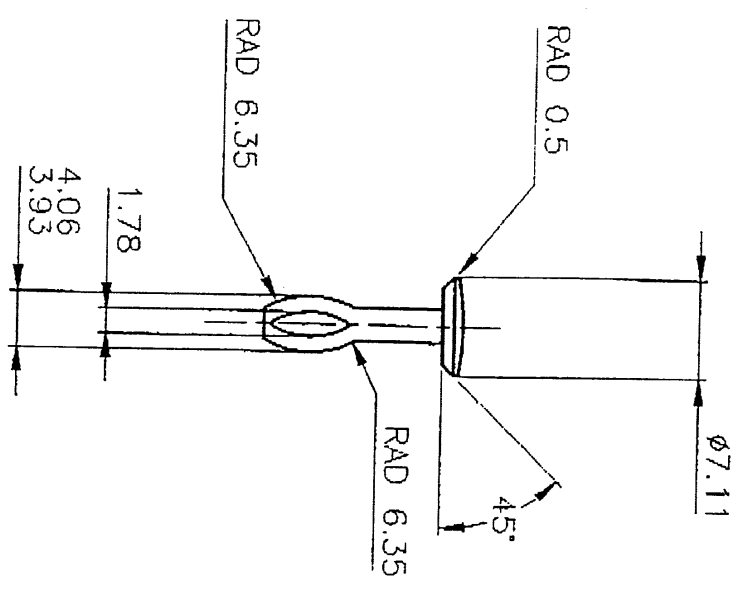

NOT A CONTROLLED COPY  
 ITW  
 28 Aug 1997  
 Basingstoke  
 RETURN TO DESIGN OFFICE

CUSTOMER DETAILS

CUSTOMER	
CUSTOMER PART No.	
CUSTOMER APPROVAL	
APPROVAL DATE	

REVISIONS		KOD. No.
ISSUE	DATE	MODIFICATION
1	26-10-94	DRAWING RAISED
		ISSUE

**Electronic Packaging**

GRAFTON WAY, WEST HAM INDUSTRIAL ESTATE,  
 BASINGSTOKE, HAMPSHIRE, RG22 6HY  
 TEL: (0256) 466772 FAX: (0256) 461900

P/R. No.	N/A	DRAWN	MCPotter
COLOUR	BLACK	DATE	26-10-94
MATERIAL	NYLON	CHECKED	
WEIGHT		DATE	

IF THIS STAMP IS NOT RED IN COLOUR THEN THIS IS AN UNCONTROLLED COPY

ALL UNSPECIFIED TOLERANCES:

0.0	±0.50
0.00	±0.25
0.000	±0.10
ANGLES	±1°

TITLE :

THUMB TAK