

3M™ Dri-Shield Moisture Barrier Bag 2700

Sizes on Page 2

Moisture Barrier Bag ~ Aluminized

3M's Dri-Shield 2700 Moisture Barrier Bag is designed for dry packaging of electronic devices. Made from multiple layers of metallized polyester and heavy gauge dissipative polyethylene, Dri-Shield 2700 bags provide superior puncture resistance and drop test performance. Bags protect SMD's from moisture and static damage. Flexible structure is easy to vacuum seal. Coded for QC traceability.



Dri-Shield 2700

3M™ Moisture Barrier Bag with 3M™ Humidity Indicator Card and 3M™ Desiccant



Standards

Meets electrical and physical requirements of MIL-PRF-81705 Type 1, EIA 583, EIA 541, EIA 625, and EOS/ESD Standards.

Specifications

Physical Properties:	Typical Values	
MVTR(g/100 sq.in./24 hrs)	<.005	ASTM F 1249
Puncture Resistance	30 lbs	FTMS 101 MTH 2065
Thickness	7.0 mils	3M 008
Tensile Strength	40 lb	ASTM D882
Seam Strength	Pass	MIL-PRF-81705
Heat Sealing Conditions:		
Temperature	300°F - 400°F	
Time	0.6 - 4.5 seconds	
Pressure	30 - 70 PSI	
Electrical Properties:		
Surface Resistivity / Resistance	ASTM D257	or ANSI/ESD STM11.11
Interior	<10 ¹² ohms/square	or <10 ¹¹ ohms
Exterior	<10 ¹² ohms/square	or <10 ¹¹ ohms
Metal	100 ohms	
Static Shielding	< 20 volts	EIA 541
Static Shielding	< 10 nJ	EOS/ESD S11.31
EMI Attenuation	45 dB	MIL-PRF-81705
Static Decay	< 0.03 seconds	FTMS 101 MTH 4046
Non-Corrosive	Pass	FTMS 101 MTH 3005
Outgassing	Pass	ASTM E595

Material Structure

7.0 mils of static dissipative polyethylene and metallized polyester create an exceptional dry package with superior puncture performance. This premium material meets or exceeds the MVTR and EMI/RFI/Static Shielding requirements of MIL-PRF-81705 Type I and EIA 583 Type I for static safe, moisture barrier packaging.

HEAVY GAUGE
STATIC DISSIPATIVE
POLYESTER

ALUMINUM SHIELD
POLYESTER
ALUMINUM SHIELD

HEAVY GAUGE
STATIC DISSIPATIVE
POLYETHYLENE

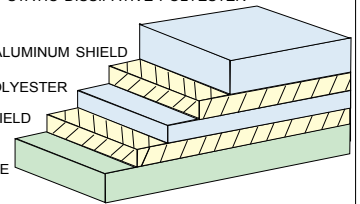

See 3M Data Sheets for these related items:

Humidity Indicator Cards (HIC's)

Desiccant

Vacuum Sealers

P R O D U C T D A T A S H E E T

Dri-Shield 2700 Moisture Barrier Bag ALUMINIZED

PRODUCT
MOISTURE BARRIER BAG, ALUMINIZED

ITEM NUMBER
D27(W)(L)

DATASHEET
1103-A

3M Electronic Solutions Division
6801 River Place Blvd.
Austin, TX 78726-9000
US and Canada: 866-722-3736
Fax: 866-722-3735
Intl: 919-718-0000; Fax: 919-774-8174
email: 3Mstaticinfo@mmm.com; www.3M.com/static

3M is a trademark of 3M Company.
All other trademarks herein are the property
of their respective owners.



© 2008

3M™ Dri-Shield Moisture Barrier Bag 2700

Moisture Barrier Bag ~ Aluminized

W"x L"	P/N	W"x L"	P/N	W"x L"	P/N
4 x 6	D2746	10 x 30	D271030	15 x 18	D271518
10 x 12	D271012	10.5 x 18	D2710.518	16 x 18	D271618
10 x 20	D271020	12 x 16	D271216		

3M™ Dri-Shield 2700 Moisture Barrier Bag

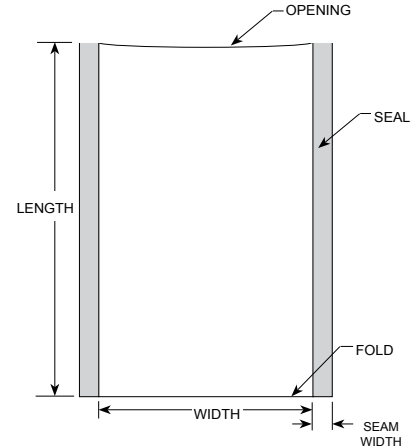

How Moisture Barrier Bags Work

Moisture barrier bags work by enclosing a device with a metal or plastic shield(s) that has a high resistance to moisture vapor permeation. Dry devices are placed inside this shield, and the moisture-laden air is evacuated. Desiccant filled pouches scavenge the remaining moisture from the bag's interior. Moisture that penetrates the bag is also entrapped by the desiccant. Humidity indicating cards report the effectiveness of the package upon device use. A label on the bag indicates the amount of exposure time devices are allowed prior to use, and the drying (re-baking) time and temperature if the exposure time is exceeded.

As the barrier property improves, the Moisture Vapor Transmission Rate (MVTR) decreases. Bags with lower MVTR provide better barrier. Aluminum foil provides the best MVTR of about 0.0003. Multiple layers of Aluminized Polyester can provide 0.02 to about 0.005.

Puncture Resistance is an important feature for barrier bags. Sharp tray edges may tear through bags with low puncture resistance.

- All standard sizes in-stock/same day shipment.
- Width is measured from inside seam to inside seam.
- Length is measured from the top edge to the bottom fold.
- Opening is in the "width" dimension.
- Custom bag sizes, custom printing, and custom hot stamping are available.
- Most sizes are packed 100 per case. Small sizes are packed 1000 or 500 per case.

P R O D U C T D A T A S H E E T

Dri-Shield 2700 Moisture Barrier Bag ALUMINIZED

PRODUCT
MOISTURE BARRIER BAG, ALUMINIZED

ITEM NUMBER
D27(W)(L")

DATASHEET
1103-A

3M Electronic Solutions Division
6801 River Place Blvd.
Austin, TX 78726-9000
US and Canada: **866-722-3736**
Fax: 866-722-3735
Intl: 919-718-0000; Fax: 919-774-8174
email: 3Mstaticinfo@mmm.com; www.3M.com/static

3M is a trademark of 3M Company.
All other trademarks herein are the property of their respective owners.



© 2008