



3M 7500 Series Respirator Half Facepiece

User Instructions for 3M™ Silicone, Small 7501, Silicone, Small 37081, Silicone, Medium 7502, Silicone, Medium 37082, Silicone, Large 7503, Silicone, Large, 37083 Half Facepieces

Important: Keep these user instructions for reference.

37077, 37078, 37079, 37081, 37082, 37083 are catalog numbers only. NIOSH approved as 3M™ Silicone, Small 7501, Silicone, Medium 7502, Silicone, Large 7503 Half Facepiece.

These instructions also apply to the 3M™ Silicone Half Facepiece Packout 37077, Small, 3M™ Silicone Half Facepiece Packout 37078, Medium, 3M™ Silicone Half Facepiece Packout 37079, Large.

GENERAL SAFETY INFORMATION

Intended Use

The 3M™ 7500 Series Half Facepiece Respirators are designed to help provide respiratory protection against certain airborne contaminants when used in accordance with all use instructions and limitations and applicable safety and health regulations.



WARNING

This respirator helps protect against certain airborne contaminants. **Misuse may result in sickness or death.** For proper use, see supervisor, or *User Instructions*, or call 3M in U.S.A., 1-800-243-4630. In Canada, call Technical Service at 1-800-267-4414.

USE INSTRUCTIONS AND LIMITATIONS

Important

Before use the wearer must read and understand these *User Instructions*. Keep these user instructions for reference. This product contains no components made from natural rubber latex.

Use For

Respiratory protection from certain airborne contaminants according to NIOSH approvals, OSHA limitations, in Canada CSA standard Z94.4 requirements, other applicable regulations and 3M instructions.

Do Not Use For

Concentrations of contaminants which are immediately dangerous to life or health, are unknown or when concentration exceeds 10 times the permissible exposure limit (PEL) in air purifying mode, 50 times PEL in supplied air mode or according to specific OSHA standards or applicable government regulations, whichever is lower.

Use Instructions

1. Failure to follow all instructions and limitations on the use of this respirator and/or failure to wear this respirator during all times of exposure can reduce respirator effectiveness and may result in sickness or death.
2. Before occupational use of this respirator a written respiratory protection program must be implemented meeting all the requirements of OSHA 29 CFR 1910.134 such as medical evaluation training and fit testing and applicable OSHA substance specific standards. In Canada, CSA standard Z94.4 requirements must be met.
3. The airborne contaminants which can be dangerous to your health include those that are so small you cannot see them.
4. Leave contaminated area immediately and contact supervisor if you smell or taste contaminants or if dizziness, irritation, or other distress occurs.
5. Store respirator away from contaminated areas when not in use.
6. Dispose of used product in accordance with applicable regulations.

Use Limitations

1. This respirator does not supply oxygen when used in air-purifying mode. Do not use in atmospheres containing less than 19.5% oxygen.
2. Do not use when concentrations of contaminants are immediately dangerous to life and health, are unknown or when concentrations exceed 10 times the permissible exposure limit (PEL) when used in air-purifying mode, or according to specific OSHA standards or applicable government regulations, whichever is lower. When used as a straight, Type C, continuous flow supplied air respirator, the Assigned Protection Factor is 50 times the PEL or TLV guidelines for half facepiece respirators.
3. Do not alter, abuse or misuse this respirator.
4. Do not use with beards or other facial hair or other conditions that prevent a good seal between the face and the faceseal of the respirator.

Time Use Limitations

1. If respirator becomes damaged, leave contaminated area immediately and repair or replace the respirator.

2. Replace filters in accordance with the filter Time Use Limitation.
3. Replace cartridges in accordance with an established change schedule or earlier if smell, taste or irritation from contaminants is detected.

NIOSH Cautions and Limitations

The following restrictions may apply. See NIOSH approval label.

- A- Not for use in atmospheres containing less than 19.5 percent oxygen.
- B- Not for use in atmospheres immediately dangerous to life or health.
- C- Do not exceed maximum use concentrations established by regulatory standards.
- D- Air-line respirators can be used only when the respirators are supplied with respirable air meeting the requirements of CGA G-7.1 Grade D or higher quality.
- E- Use only the pressure ranges and hose lengths specified in the User's Instructions.
- G- If airflow is cut off, switch to filter and/or cartridge or canister and immediately exit to clean air.
- H- Follow established cartridge and canister change schedules or observe ESLI to ensure that cartridge and canisters are replaced before breakthrough occurs.
- J- Failure to properly use and maintain this product could result in injury or death.
- K- The Occupational Safety and Health Administration regulations require gas-proof goggles to be worn with this respirator when used against formaldehyde.
- L- Follow the manufacturer's User's Instructions for changing cartridges, canister and/or filters.
- M- All approved respirators shall be selected, fitted, used, and maintained in accordance with MSHA, OSHA, and other applicable regulations.
- N- Never substitute, modify, add, or omit parts. Use only exact replacement parts in the configuration as specified by the manufacturer.
- O- Refer to User's Instructions, and/or maintenance manuals for information on use and maintenance of these respirators.
- P- NIOSH does not evaluate respirators for use as surgical masks.
- S- Special or critical User's Instructions and/or specific use limitations apply. Refer to User's Instructions before donning.

S – Special or Critical User Instructions

3M™ Mercury Vapor Cartridges (6009 and 60929) are equipped with passive 3M™ End of Service Life Indicators (ESLI). The color change indicator must be readily visible when wearing the respirator without manipulation. If you cannot readily see the ESLI, do not use. Mercury vapor cartridges must be discarded when the ESLI changes color; or within 30 days of opening packaging; or when ESLI becomes dirty or damaged; or when odors of vapors or gases become noticeable, whichever occurs first. Mercury vapor has no odor.

LIST OF PRODUCTS

3M™ 7500 Series Half Facepiece and Parts

Facepieces

Facepieces do not include cartridges, filters or retainers.

Number	Product Name
7501 / 37081	Half Facepiece, (Small)
7502 / 37082	Half Facepiece, (Medium)
7503 / 37083	Half Facepiece, (Large)

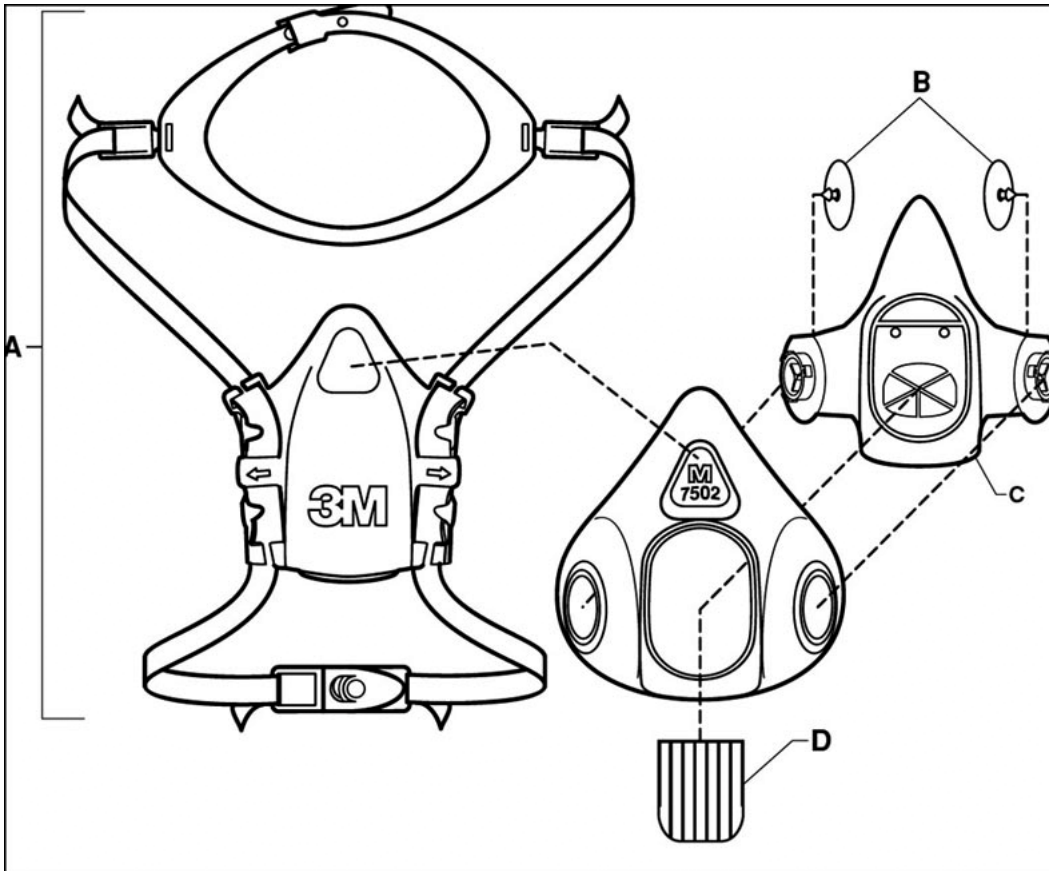

Replacement Parts

- A** 7581 Head Harness Assembly
- B** 7582 Inhalation Valves
- C** 7586 Cartridge/Filter Holder
- D** 7583 Exhalation Valve

Accessories

- 504 *(07065) Respirator Cleaning Wipe
- 601 Quantitative Fit Test Adapter
- 6880 Bayonet Cap

CAUTION: Failure to properly dispose of spent cartridges, filters, or respirators contaminated by hazardous materials can result in environmental harm. Handling, transportation and disposal of spent

cartridges, filters, or respirators must comply with all applicable federal, state, and local laws and regulations.

3M™ Cartridges

***AAD part numbers are catalog numbers only. NIOSH approved as OH&ESD part numbers**

Number	Product Name	Description
		NIOSH Approved (for respiratory protection against the following contaminants up to ten times the permissible exposure limit)
6001 *(07146)	Organic Vapor	Certain organic vapors
6002	Acid Gas	Chlorine, hydrogen chloride, and sulfur dioxide or chlorine dioxide or hydrogen sulfide (escape only)
6003 *(07147)	Organic Vapor/Acid Gas	Certain organic vapors, chlorine, hydrogen chloride, and sulfur dioxide or hydrogen sulfide (escape only) or hydrogen fluoride
6004	Ammonia and Methylamine	Ammonia and methylamine
6005	Formaldehyde and Organic Vapor	Formaldehyde and certain organic vapors ¹
6006	Multi-Gas and Vapor	Certain organic vapors, chlorine, hydrogen chloride, chlorine dioxide, sulfur dioxide, ammonia, methylamine, formaldehyde, hydrogen fluoride, or hydrogen sulfide (escape only) ¹
6009	Mercury Vapor	Mercury vapor or chlorine
60921	Organic Vapor/P100	Certain organic vapors and particulates
60922	Acid Gas/P100	Chlorine, hydrogen chloride, and sulfur dioxide or chlorine dioxide or hydrogen sulfide (escape only) and particulates
60923	Organic Vapor/Acid Gas/P100	Certain organic vapors, chlorine, hydrogen chloride, and sulfur dioxide or hydrogen sulfide (escape only) or hydrogen fluoride, and particulates
60924	Ammonia/Methylamine/P100	Ammonia and methylamine and particulates
60925	Formaldehyde/P100	Formaldehyde and certain organic vapors and particulates ¹
60926	Multi-Gas and Vapor/P100	Certain organic vapors, chlorine, hydrogen chloride, chlorine dioxide, sulfur dioxide, ammonia, methylamine, formaldehyde, hydrogen fluoride or hydrogen sulfide (escape only) and particulates ¹
60928	Organic Vapor/Acid Gas/P100	Certain organic vapors, chlorine, hydrogen chloride, and sulfur dioxide or hydrogen sulfide (escape only) or hydrogen fluoride and particulates ²
60929	Mercury Vapor/Chlorine/P100	Mercury vapor or chlorine and particulates

¹ OSHA regulations require gas proof goggles be worn with half facepiece respirators when used against formaldehyde.

² 3M recommended for use against methylbromide or radioiodine up to 5 ppm with daily cartridge replacement.

Service Life of Chemical Cartridges and Filters

6000 series cartridges should be used before the expiration date on cartridge packaging. The useful service life of these cartridges will depend upon the activity of the wearer (breathing rate), specific type, volatility and concentration of contaminants and environmental conditions such as humidity, pressure, and temperature. Cartridges must be replaced in accordance with an established change schedule, or earlier if smell, taste or irritation from the contaminant is detected.

Filters must be replaced if they become damaged, soiled or if increased breathing resistance occurs. N-series should not be used in environments containing oils. R-series filters may be limited to 8 hours of continuous or intermittent use if oil aerosols are present. In environments containing only oil aerosols, P-series filters should be replaced after 40 hours of use or 30 days, whichever is first.

3M™ Filters/Adapters/Retainers

Number	Product Name
501 *(07054)	Filter Retainer for 5N11 and 5P71 Filters
502	Filter Adapter for 2000 Series and 7093 Filters
2071	P95 Particulate Filter
2076HF	P95 Particulate Filter, hydrogen fluoride, with nuisance level acid gas relief ¹
2078	P95 Particulate Filter, 3M recommended for ozone protection ² , with nuisance level organic vapor/acid gas relief ¹
2091	P100 Particulate Filter
2096	P100 Particulate Filter, with nuisance level acid gas relief ¹
2097 *(07184)	P100 Particulate Filter, 3M recommended for ozone protection ² , with nuisance level organic vapor relief ¹
5N11	N95 Particulate Filter
5P71 *(07194)	P95 Particulate Filter
7093	P100 Particulate Filter

¹ 3M recommended for relief against nuisance levels of acid gases or organic vapors. Nuisance level refers to concentrations not exceeding OSHA PEL or applicable government occupational exposure limits, whichever is lower. Do not use for respiratory protection against acid gases or organic vapors.

² 3M recommended for ozone protection up to 10 times the OSHA PEL. Note: This product is not NIOSH approved for ozone protection.

ASSEMBLY INSTRUCTIONS

3M™ 6000 Series Cartridge Assembly

Align cartridge notch with arrow on facepiece, as shown, and push together. (Fig. 1) Turn cartridge clockwise to stop (1/4 turn). (Fig. 2)

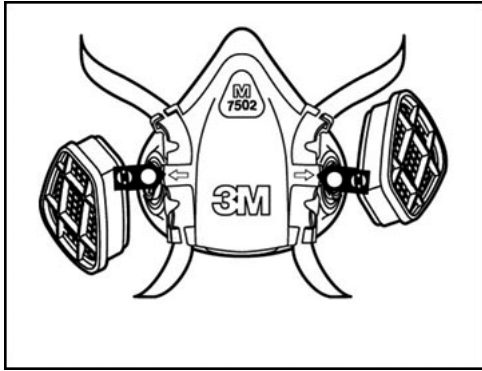

Fig. 1

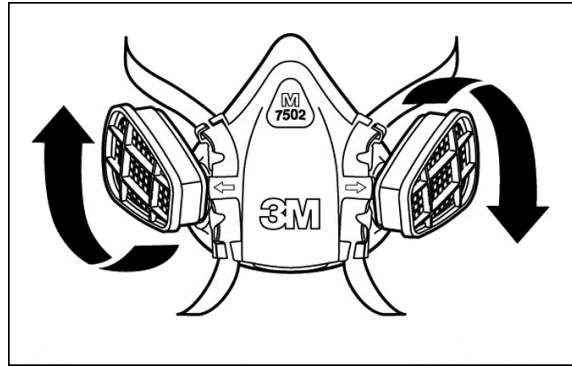

Fig.2

3M™ 5N11 and 5P71 Filters

1. Place filter into 3M™ 501 *(07054) Retainer so printed side of filter faces the cartridge. (Fig. 3)
2. Press cartridge into filter retainer. It should snap securely into filter retainer. When correctly installed, filter should completely cover face of cartridge.
3. To replace filter, remove retainer by lifting on TAB.

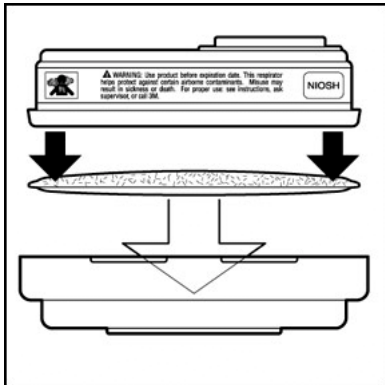

Fig. 3

3M™ 2000 Series and 7093 Filters

Align opening of filter with filter attachment on facepiece. Turn filter clockwise until it is firmly seated and cannot be further turned. Repeat for second filter.

3M™ 502 Adapter Assembly and Filter Attachment

1. Align adapter over cartridge. Engage front snap by squeezing front of cartridge and adapter together, placing thumbs of both hands over top of adapter and fingers along bottom sides of cartridge. (Fig. 4)
2. Engage back snap by squeezing back side of cartridge and adapter together using the same hand positions. (Fig. 5) An audible click should be heard as each snap is engaged.

- Place filter onto the filter holder so that filter comes into even contact with gasket. Twist clockwise a quarter turn until it is firmly seated and filter cannot be turned further. Repeat for second filter.

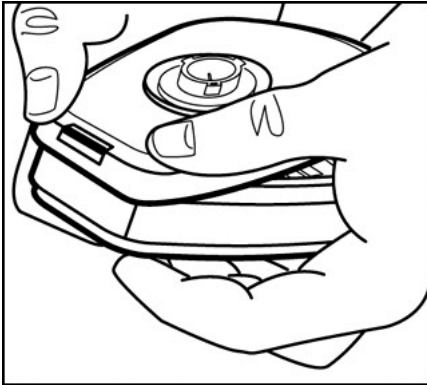

Fig. 4

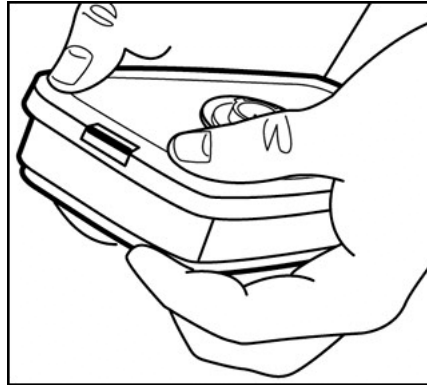

Fig. 5

Note: The 3M 502 adapter once installed on a 3M™ 6000 Series Cartridge is not to be removed and reused as leakage may occur.

⚠ WARNING

To meet the U.S. National Institute for Occupational Safety and Health (NIOSH) requirement for minimum (4 CFM/115 lpm) and maximum (15 CFM/424 lpm) air flow, the air control valves approved for use with the 3M 7500 Series Respirators must be operated within the correct supply pressure ranges and hose lengths. **Failure to do so may result in sickness or death.**

⚠ WARNING

OSHA standard 1910.134 requires that employers provide breathing air which shall “meet at least the requirements of the specification for Grade D breathing air as described in Compressed Gas Association Commodity specification G-7.1-1997.” This air must come from a suitable external source (e.g., breathing air compressor or bottle with breathing quality air). **Failure to do so may result in sickness or death.** The 7500 Series respirator itself DOES NOT provide Grade D breathing air or air that meets CSA Standard CAN3-Z180.1-00.

Assembly of Dual Airline Breathing Tubes

- Hold the facepiece in front of you so that the 3M logo is facing you. Align the two branches of the breathing tube over the two bayonet mounts on facepiece. For the 3M™ SA-1500 or SA-1600 Breathing Tubes, make sure that 3M logo on breathing tube and on half facepiece are both facing towards you. For 3M SA-2500 *(07148) or SA-2600 *(37001) Breathing Tubes, make sure that the 3M logo on breathing tube is facing in opposite direction to 3M logo on half facepieces. (Fig. 6) 3M SA-1500/SA-2500 shown.
- Twist each branch of breathing tube clockwise a quarter turn until it is firmly seated in the bayonet and cannot be turned further. (Fig. 7 and 8) Do not forcibly overturn as the bayonet could be damaged. 3M SA-1500/SA-2500 shown.
- Attach airline to approved air regulators per pressure schedules in dual airline, supplied air respirators *User Instructions*.

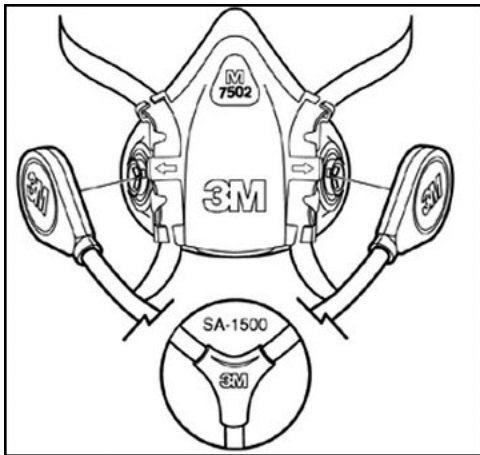

Fig. 6

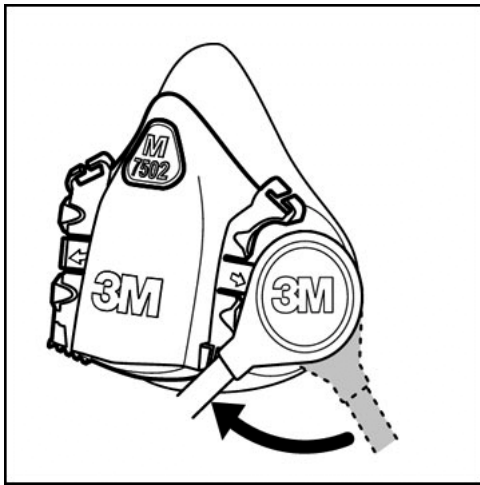

Fig. 7

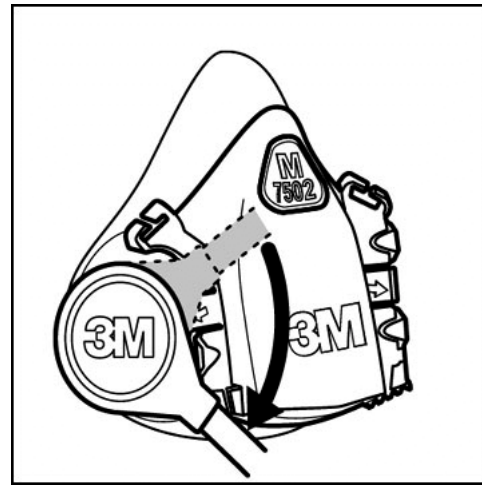

Fig. 8

Assembly of 3M Combination Dual Airline Breathing Tubes with Cartridges and/or Filters

The 3M SA-1600 (front-mounted) and SA-2600 *(37001) (back-mounted) versions of the 3M dual airline breathing tubes allow use of selected, NIOSH-approved 3M 6000 series cartridges and 2000 series filters. For listing of approved cartridges and filters, reference NIOSH approval label included with 3M dual airline breathing tubes with cartridges and/or filters, do the following:

1. Attach 3M SA-1600 or SA-2600 breathing tubes to facepiece per the procedures outlined previously. The procedure is identical to the 3M SA-1500 and SA-2500 *(07148) models.
2. Make a selection of cartridges and/or filters that meets your respiratory protection requirements, and attach to the outer bayonets of 3M SA-1600 or SA-2600 breathing tubes. (Fig. 9)
3. Don facepiece per procedures outlined in Donning Respirator instructions.
4. After being properly fit tested, perform a positive and negative pressure user seal check per procedures outlined in User Seal Check instructions.

If you cannot achieve a proper fit, do not enter the contaminated area. See your supervisor.

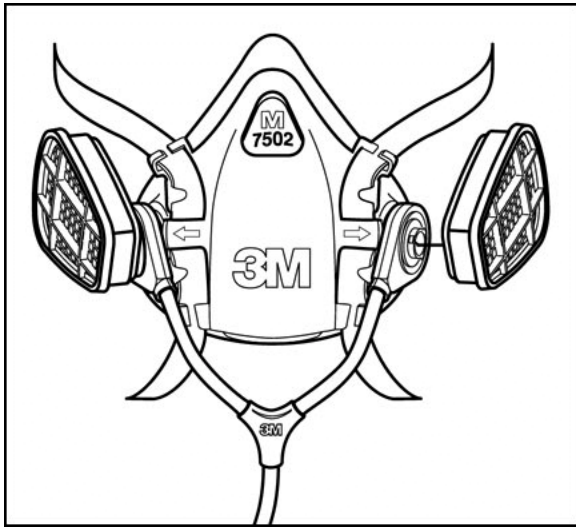

Fig. 9

Using the 3M Combination Dual Airline Breathing Tubes without Cartridges and/or Filters

To use the 3M SA-1600 or SA-2600 *(37001) breathing tubes without cartridges or filters, attach a 3M™ 6880 *(37002) Bayonet Cap to each outer bayonet mount on the breathing tube. When used as a straight, Type C, continuous flow supplied air respirator, the Assigned Protection Factor is 50 times the PEL or TLV guidelines for half facepiece respirators.

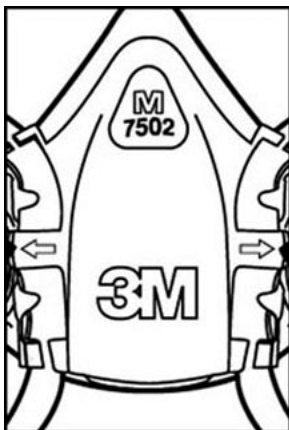

Fig. 10

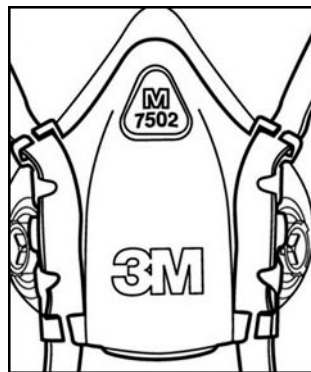

Fig. 11

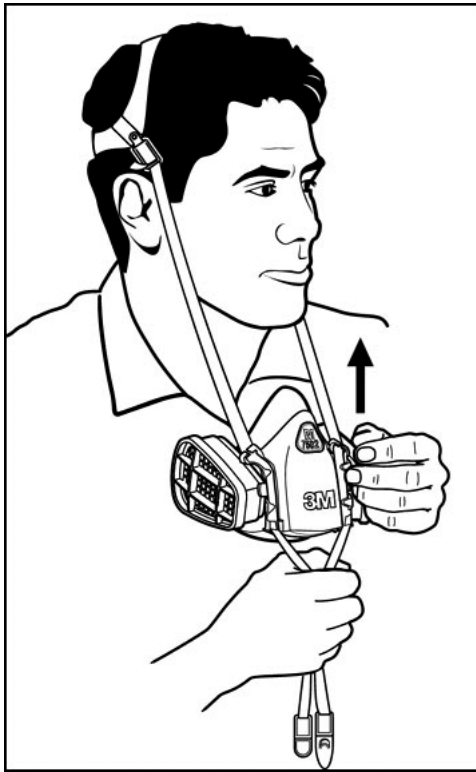

Fig. 12

FITTING INSTRUCTIONS

The 7500 Series Half Facepiece suspension can be configured as a standard fixed suspension or a drop down suspension for individuals using hard hats. Position straps beneath locking tabs for standard fixed suspension (Fig. 10) or position straps over locking tabs for optional drop down suspension. (Fig. 11)

Donning (Standard Suspension)

1. Adjust head cradle size as needed to fit comfortably on head. Place the respirator over the mouth and nose, then pull the head harness over the crown of the head. Grasp the bottom straps, place them at the back of the neck and hook them together.
2. Pull the ends of the straps to adjust the tightness. Do not over-tighten. (Fig. 13)
3. Perform a positive and/or negative pressure user seal check each time the respirator is donned.

If you cannot achieve a proper fit, do not enter the contaminated area. See your supervisor.



Fig. 13

Donning (Drop Down Suspension)

1. Adjust head cradle size as needed to fit comfortably on head.
2. While holding head harness strap ends with one hand, slide the facepiece up onto your face. (Fig. 12)
Next grasp strap ends with each hand and hook them together at back of neck.
3. Adjust strap tension by pulling strap ends until a secure fit is obtained. Balance strap tension by adjusting at top and bottom strap buckles. Do not over tighten. (Strap tension may be decreased by pushing out on back side of buckles.) Perform user seal check as described.

If you cannot achieve a proper seal, do not enter contaminated area. See your supervisor.

User Seal Checks

Always check the seal of the respirator on your face before entering a contaminated area.

Positive Pressure User Seal Check

1. Cover the opening in exhalation valve cover with hand and exhale gently. (Fig. 14) If facepiece bulges slightly and no air leaks are detected between your face and facepiece, a proper seal has been obtained.
2. If face seal air leakage is detected, reposition respirator on your face and/or readjust tension of the elastic straps to eliminate leakage.

If you cannot achieve a proper seal, do not enter contaminated area. See your supervisor.



Fig. 14

Negative Pressure User Seal Check (with 6000 Series Cartridges)

Note: Use of 3M 501 filter retainer may aid respirator wearer in conducting a negative pressure user seal check.

1. Place palms of hands to cover face of cartridge or open area of 3M™ 501 *(07054) Filter Retainer, when retainer is attached to the cartridge, to restrict air flow. (Fig. 15)
2. Inhale gently. If you feel facepiece collapse slightly and pull closer to your face with no leaks between the face and facepiece, a proper seal has been obtained.
3. If faceseal air leakage is detected, reposition respirator on face and/or readjust tension of straps to eliminate air leakage.

If you cannot achieve a proper seal, do not enter contaminated area. See your supervisor.

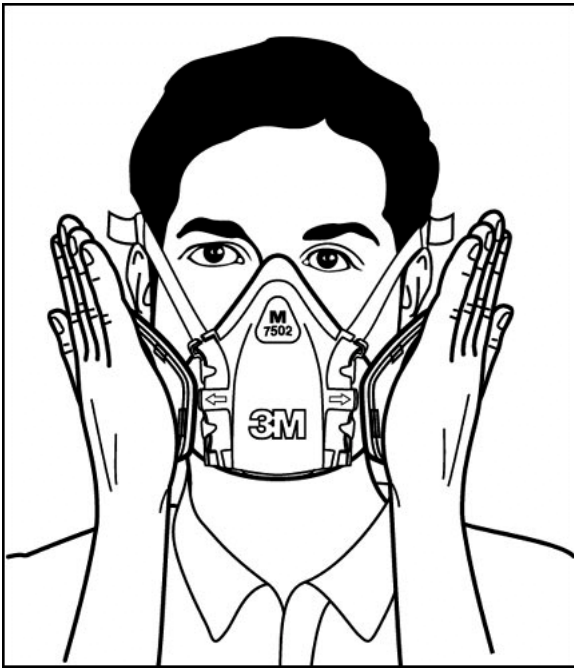

Fig. 15

Negative Pressure User Seal Check (with 2000 Series Filters)

1. Place your thumbs onto the center portion of the filters, restricting airflow into the breathing tube of filters, and inhale gently. If you feel facepiece collapse slightly and pull closer to your face with no leaks between the face and facepiece, a proper seal has been obtained. (Fig. 16)
2. If face seal air leakage is detected, reposition respirator on face and/or readjust tension of straps to eliminate the leakage.

If you cannot achieve a proper seal, do not enter contaminated area. See your supervisor.



Fig. 16

Negative Pressure User Seal Check (with 7093 Filters)

1. Using hands press filter covers toward facepiece and inhale gently. If you feel facepiece collapse slightly and pull closer to your face with no leaks between the face and facepiece a proper seal has been obtained (Fig. 15)
2. If faceseal air leakage is detected, reposition respirator on face and/or readjust tension of straps to eliminate the leakage.

If you cannot achieve a proper seal, do not enter contaminated area. See your supervisor.

Note: Before assigning any respirator to be worn in a contaminated area, a qualitative or quantitative fit test must be performed per the local requirements or OSHA Standard 1910.134.

Quantitative (QNFT) and Qualitative (QLFT) Fit Testing

The effectiveness of a respirator will be reduced if it is not fitted properly. Therefore, either quantitative or qualitative fit testing must be conducted prior to the respirator being issued and used.

Note: Fit testing is both a U.S. Occupational Safety and Health Administration (OSHA) and Canadian requirement.

To conduct QNFT with the 7501 *(37081), 7502 *(37082), 7503 *(37083) Half Respirator Facepiece, place a 3M™ 601 Fit Test Adapter on either side of the half facepiece. Place a 3M™ 2091 Filter or 3M™ 7093 P100 Filter on the 601 fit test adapter and the other side of the half facepiece.

Qualitative Fit Testing (QLFT) can be conducted with any approved particulate filters. The 3M FT-10 (sweet) or FT-30 (bitter) QLFT fit test can be utilized to conduct the fit testing. For further information concerning QLFT or QNFT contact 3M OH&ESD Technical Service toll free in U.S.A., 1-800-243-4630 or 3M at your locations (see Worldwide Locations section). In Canada, call Technical Service at 1-800-267-4414.

INSPECTIONS, CLEANING AND STORAGE

Inspection Procedure

This respirator must be inspected before each use to ensure it is in proper operating condition. Any damaged or defective parts must be replaced before use. The following procedure is recommended:

1. Check the facepiece for cracks, tears and dirt. Examine the inhalation valves for signs of distortion, cracking or tearing.
2. Check that the head straps are intact and have good elasticity.
3. Examine all plastic parts and gasket areas for signs of cracking or fatiguing and replace if necessary. Remove the exhalation valve cover and examine the exhalation valve and seat for signs of dirt, distortion, cracking, or tearing. Replace the valve if necessary. Secure the valve cover prior to use. (Fig. 17)

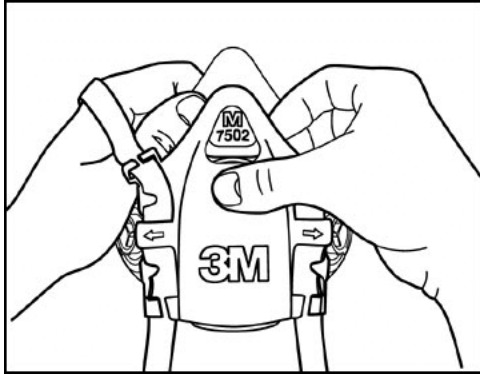

Fig. 17

Cleaning

CAUTION: Cleaning with solvents may degrade some respirator components and reduce respirator effectiveness. Inspect all respirator components before each use to ensure proper operating conditions.

Cleaning is recommended after each use

1. Remove cartridges and/or filters.
2. Clean facepiece (excluding filters and cartridges), with 3M™ 504 *(07065) Respirator Wipes (not to be used as the only method of cleaning) or by immersing in warm cleaning solution, water temperature not to exceed 120° F, and scrub with soft brush until clean. Add neutral detergent if necessary. Do not use cleaners containing lanolin or other oils.
3. Disinfect facepiece by soaking in a solution of quaternary ammonia disinfectant or sodium hypochloride (1 oz. [30 ML] household bleach in 2 gallons [7.5 L] of water), or other disinfectant.
4. Rinse in fresh, warm water and air dry in non-contaminated atmosphere.
5. The cleaned respirator should be stored away from contaminated areas when not in use.

Replacement Instructions

Replacement components are available in a spare parts kit R-7530ES *(37080) or as individual components.

3M™ Head Harness Assembly

1. Remove 3M™ 7581 valve cover/Head Harness Assembly by pulling away from facepiece. (Fig. 17)
2. Replace 3M™ 7581 valve cover/Head Harness assembly by aligning parts and snapping together. When properly engaged an audible snap should be heard.

3M™ Exhalation Valve

1. Remove 3M™ valve cover/Head Harness Assembly by pulling away from facepiece. (Fig. 17)
2. Remove 3M™ 7583 Exhalation Valve from valve seat by pulling each valve stem separately from holes. (Fig. 18)
3. Replace 3M™ 7583 Exhalation Valve by inserting stems and pulling through from opposite side until they are both snapped in place. (Fig. 19 and 20)
4. Replace 3M™ 7581 valve cover/Head Harness Assembly.

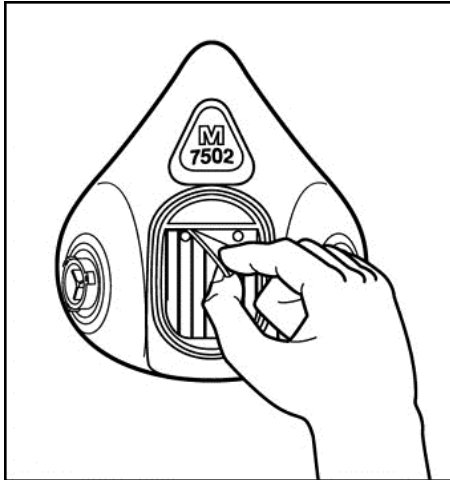

Fig. 18

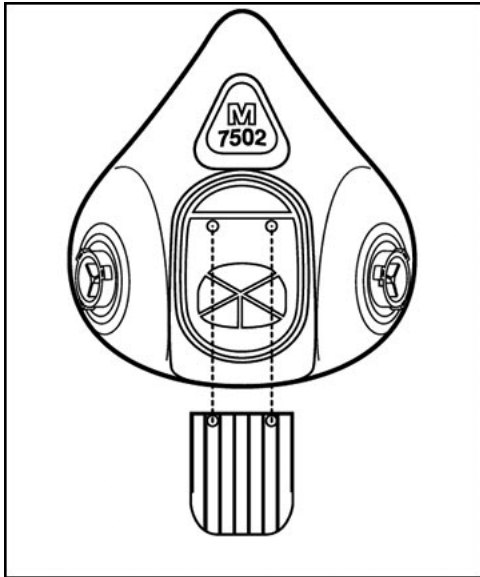

Fig. 19



Fig. 20

3M™ Inhalation Valve

1. Remove 3M™ 7582 Inhalation Valve by grasping and pulling valve stem from seat.
2. Replace valve by pressing stem into hole and manipulating stem tip until valve seats completely.

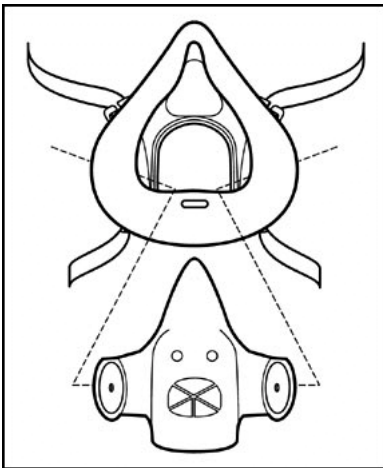

Fig. 21

3M™ Cartridge/Filter Holder

1. Remove 3M™ 7581 valve cover/Head Harness Assembly by pulling away from facepiece. (Fig. 17)
2. Pull facepiece from 3M™ 7581 Cartridge/Filter Holder. (Fig. 21)
3. Replace 3M™ 7586 Cartridge/Filter Holder by aligning with facepiece and fully engaging holder ports with holes in facepiece.
4. Replace 3M™ 7581 valve cover/Head Harness Assembly by snapping into place.

FOR MORE INFORMATION and assistance on 3M occupational health and environmental safety products, contact your local 3M representative or call 3M OH&ESD Technical Service toll free in U.S.A., 1-800-243-4630. In Canada, call Technical Service at 1-800-267-4414.

**3M Occupational Health and
Environmental Safety Division**

3M Center, Building 235-2W-70
P.O. Box 33010
St. Paul, MN 55133-3010
Assembled in Mexico from U.S.A. components.

©3M 2001

38-9017-4501-8

3M Automotive Aftermarket Division

3M Center, Building 223-6N-01
P.O. Box 33223
St. Paul, MN 55133-3223
Assembled in Mexico from U.S.A. components.