

PBA Series
POWERSTAT®
Variable Transformer
Enclosures



*the design choice
for protection of
POWERSTAT® Variable Transformers*

Superior
Electric

PBA Series POWERSTAT® Variable Transformer Enclosures

PBA Series Enclosures have been specifically designed to house open construction (suffix U) type POWERSTAT Variable Transformers. These Enclosures are constructed of heavy gauge sheet metal and are supplied completely assembled. A full range of knockouts and all required hardware is included.

PBA Series Enclosures are NEMA Type 1 as defined in NEMA Standard ICS 1-110. As such, they are designed to protect users against accidental contact with the enclosed POWERSTAT Variable Transformer. They are intended for use indoors in areas where unusual service conditions do not exist.



PBA50 Series Enclosures



PBA10, PBA30 and PBA40 Series Enclosures

Basic Series

The PBA10, PBA30 and PBA40 Series Enclosures house small to medium frame size POWERSTAT Variable Transformers which have power ratings between 0.5 kVA, single phase and 15 kVA, three phase. They are intended for wall and bench mounting and provide the proper ventilation required to allow operation of the enclosed POWERSTAT Variable Transformer at its maximum rating. For additional protection, PBA10 Series Enclosures are provided with cover plates which may be placed over the ventilation openings. If covers are installed, the enclosed POWERSTAT Variable Transformer must be derated 15 percent. In addition, the maximum current rating of all 21 Series units must be derated by 10 percent when enclosed in any PBA10 Series Enclosure.

The PBA50-N01-A, PBA50-N01-B, PBA50-N01-C, PBA50-N01-D and PBA50-N01-E Enclosures are for use with manually operated and motor driven, open construction 1156DU, 1256DU and 1296DU Series units that have ratings between 6 kVA, single phase and 60 kVA, three phase. These single door, floor mounted Enclosures can be fitted with optional Caster Kit 218832-001.

Enclosures for larger motor driven 1156DU, 1256DU and 1296DU Series POWERSTAT Variable Transformers which have power ratings above 60 kVA are available as factory installed options only. Factory installation is required because of the size of the units and the need to provide fans of the proper size and voltage to prevent heat buildup. Type number selection of these combined PBA

Enclosure/POWERSTAT Variable Transformer units is explained in the Enclosure Selection Chart for motor Driven POWERSTAT Variable Transformers on page 5. The type numbers of Enclosures PBA50-N01-F, PBA50-N01-DD, PBA50-N01-EE, PBA50-N01-FF and PBA50-N01-GG are included for reference only.

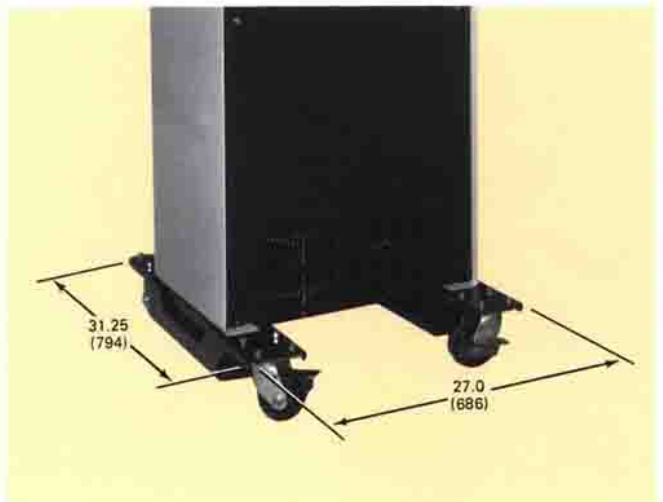

PBA50 Series Enclosure with Caster Kit 218832-001

An installed Caster Kit will raise the unit approximately 1.88 inches (12.7mm). The shipping weight of the Kit is approximately 60 lbs. (27 kg).

Installation is easy as 1-2-3...

1.



Ready.

2.



Set.

3.



Go.

Selection & Ordering

To select the proper PBA Series POWERSTAT Variable Transformer Enclosure, use the Type Number Designation Chart below to determine if the POWERSTAT is (1) manually operated or motor driven, (2) the Series (frame size)

and (3) the number of ganged assemblies. This information is required to select the proper PBA Enclosure from Selection Charts on pages 4 and 5.

POWERSTAT® Variable Transformer Applicable Type Number Designations

Example:

60MB1296DU-2S



APPLICABLE PREFIXES

Prefix	Description	Suffix	Description
5/6M	5- or 6-Second Motor Drive	-2 to -27	Units in Ganged Assembly
15/18M	15- or 18-Second Motor Drive	X	220 V, 50 Hz Motor Drive
30/36M	30- or 36-Second Motor Drive	-40	40-Volt Series
60/72M	60- or 72-Second Motor Drive	U*	Open Construction (Unscreened)
DM	Adjustable/Digital Motor Drive	N01	NEMA 1 Enclosure
LW	Isolated Secondary Series	D†	Open-Delta
		P†	Parallel
		PS†	Series-Parallel
		S†	Series
		Y†	Wye

APPLICABLE SUFFIXES

*21-22 Series units have open construction but do not use a U suffix.
†D, P, PS, S and Y suffixed 1156D, 1256D and 1296D Series units are factory electrically connected.

To accommodate special customer requirements, any POWERSTAT Variable Transformer can be installed in a larger Enclosure. No Enclosure modification is required when selecting a taller Enclosure within the same PBA Series. However, the knob on manually operated POWERSTAT Variable Transformers should be brought out of the base end of the unit to avoid the need for a longer shaft. Using an Enclosure designed for a larger frame size assembly may require drilling additional mounting holes. The factory invites questions regarding modification or selection of Enclosures.

Customized Assemblies Supplied on Special Order:

- Other NEMA Style Enclosures
- Voltage and/or Current Metering
- Fuses and/or Circuit Breakers
- Line Cords and/or Receptacles
- Raise/Lower Switches
- Tropicalization

PBA Series POWERSTAT® Variable Transformer Enclosures

Type Number Designations

Example 1:

PBA30-N01-3

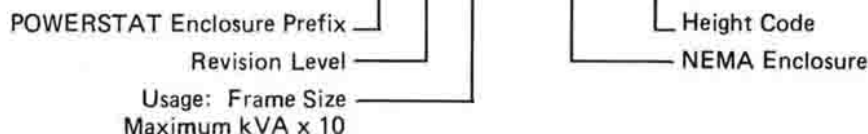

Manually Operated POWERSTAT Variable Transformer Enclosure Selection Chart

For Use With POWERSTAT Variable Transformer:			Order POWERSTAT Enclosure:	
Series	Ganged Assemblies	Type	Type	Net Wt. Lbs. (Kg)
21 & 22	1	21, 22, 21-40	PBA10-N01-1	7 (3.2)
	2	21-2, 22-2, 21-40-2	PBA10-N01-2	11 (5.0)
	3	21-3, 22-3, 21-40-3	PBA10-N01-3	13 (5.9)
116C & 117C	1	116CU, 117CU, 116CU-40	PBA10-N01-1	7 (3.2)
	2	116CU-2, 117CU-2, 116CU-40-2	PBA10-N01-2	11 (5.0)
	3	116CU-3, 117CU-3, 116CU-40-3	PBA10-N01-3	13 (5.9)
216C & 217C	1	216CU, 217CU	PBA10-N01-1	7 (3.2)
	2	216CU-2, 217CU-2	PBA10-N01-2	11 (5.0)
	3	216CU-3, 217CU-3	PBA10-N01-3	13 (5.9)
126 & 226	1	126U, 226U	PBA30-N01-1	9 (4.1)
	2	126U-2, 226U-2	PBA30-N01-2	14 (6.4)
	3	126U-3, 226U-3	PBA30-N01-3	17 (7.7)
136B, 236B & LW136B	1	136BU, 236BU, LW136BU	PBA30-N01-1	9 (4.1)
	2	136BU-2, 236BU-2, LW136BU-2	PBA30-N01-2	14 (6.4)
	3	136BU-3, 236BU-3, LW136BU-3	PBA30-N01-3	17 (7.7)
146 & 246	1	146U, 246U	PBA40-N01-1	12 (5.4)
	2	146U-2, 246U-2	PBA40-N01-2	18 (8.2)
	3	146U-3, 246U-3	PBA40-N01-3	22 (10.0)
1156D, 1256D & 1296D	1	1156DU, 1256DU, 1296DU	PBA50-N01-A	100 (45.4)
	2	1156DU-2, 1256DU-2, 1296DU-2	PBA50-N01-B	130 (59.0)
	3	1156DU-3, 1256DU-3, 1296DU-3	PBA50-N01-C	160 (72.6)
	4-5	1156DU-4, -5; 1256DU-4, -5; 1296DU-4, -5;	PBA50-N01-D	190 (86.2)
	6	1156DU-6, 1256DU-6, 1296DU-6	PBA50-N01-E	220 (99.8)

Factory Installed Enclosures

The PBA Enclosures on the facing page are listed for reference only. They are not offered separately but must be ordered and shipped as factory installed assemblies with the desired POWERSTAT Variable

Transformer. When ordering combined assemblies, substitute N01 for the letter U in the motor driven type number and disregard the PBA Enclosure type number. For example MB1156DN01-7.

Example 2: 7-27 Gang Motor Driven & PBA Enclosure Combination Types

60MB1296DN01-7P

Substitute Designation for
POWERSTAT Variable Transformer &
NEMA 1 Enclosure Combination Types

Motor driven POWERSTAT Variable Transformer Enclosure Selection Chart

For Use With Motor Driven POWERSTAT Variable Transformer:			Order POWERSTAT Enclosure:	
Series	Ganged Assemblies	Type	Type	Net Wt. Lbs. (Kg)
21 & 22	1	M/MB21, M/MB22, M/MB21-40	PBA10-N01-2	11 (5.0)
	2	M/MB21-2, M/MB22-2, M/MB21-40-2	PBA10-N01-3	13 (5.9)
	3	M/MB21-3, M/MB22-3, M/MB21-40-3	PBA10-N01-4	16 (7.3)
116C & 117C	1	MB116CU, MB117CU, MB116CU-40	PBA10-N01-2	11 (5.0)
	2	MB116CU-2, MB117CU-2, MB116CU-40-2	PBA10-N01-3	13 (5.9)
	3	MB116CU-3, MB117CU-3, MB116CU-40-3	PBA10-N01-4	16 (7.3)
216C & 217C	1	MB216CU, MB217CU	PBA10-N01-2	11 (5.0)
	2	MB216CU-2, MB217CU-2	PBA10-N01-3	13 (5.9)
	3	MB216CU-3, MB217CU-3	PBA10-N01-4	16 (7.3)
116C & 117C	1	M116CU, M117CU, M116CU-40, DM116CU, DM117CU	PBA30-N01-2	14 (6.4)
	2	M116CU-2, M117CU-2, M116CU-40-2, DM116CU-2, DM117CU-2	PBA30-N01-3	17 (7.7)
	3	M116CU-3, M117CU-3, M116CU-40-3, DM116CU-3, DM117CU-3	PBA30-N01-4	21 (9.5)
216C & 217C	1	M216CU, M217CU, DM216CU, DM217CU	PBA30-N01-2	14 (6.4)
	2	M216CU-2, M217CU-2, DM216CU-2, DM217CU-2	PBA30-N01-3	17 (7.7)
	3	M216CU-3, M217CU-3, DM216CU-3, DM217CU-3	PBA30-N01-4	21 (9.5)
126 & 226	1	MC126U, MC226U, DM126U, DM226U	PBA30-N01-2	14 (6.4)
	2	MC126U-2, MC226U-2, DM126U-2, DM226U-2	PBA30-N01-3	17 (7.7)
	3	MC126U-3, MC226U-3, DM126U-3, DM226U-3	PBA30-N01-4	21 (9.5)
136B, 236B & LW136B	1	MD136BU, MD236BU, DM136BU, DM236BU, MDLW136BU	PBA30-N01-2	14 (6.4)
	2	MD136BU-2, MD236BU-2, DM136BU-2, DM236BU-2, MDLW136BU-2	PBA30-N01-3	17 (7.7)
	3	MD136BU-3, MD236BU-3, DM136BU-3, DM236BU-3, MDLW136BU-3	PBA30-N01-4	21 (9.5)
146 & 246	1	M146U, M246U, DM146U, DM246U	PBA40-N01-2	18 (8.2)
	2	M146U-2, M246U-2, DM146U-2, DM246U-2	PBA40-N01-3	22 (10.0)
	3	M146U-3, M246U-3, DM146U-3, DM246U-3	PBA40-N01-4	27 (12.2)
1156D, 1256D & 1296D	1	MB1156DU, MB1256DU, MB1296DU, DM1156DU, DM1256DU, DM1296DU	PBA50-N01-B	130 (59.0)
	2	MB1156DU-2, MB1256DU-2, MB1296DU-2, DM1156DU-2, DM1256DU-2, DM1296DU-2	PBA50-N01-C	160 (72.6)
	3-4	MB1156DU-3, -4; MB1256DU-3, -4; MB1296DU-3, -4; DM1156DU-3, -4; DM1256DU-3, -4; DM1296DU-3, -4	PBA50-N01-D	190 (86.2)
	5-6	MB1156DU-5, -6; MB1256DU-5, -6; MB1296DU-5, -6; DM1156DU-5, -6; DM1256DU-5, -6; DM1296DU-5, -6	PBA50-N01-E	220 (99.8)

PLEASE NOTE: POWERSTAT Variable Transformers with digital motor drives (DM prefix) are shipped with protective covers over the motor drive. For easy access to the motor drive, the cover should be removed before installing the unit in its Enclosure.

Motor Driven POWERSTAT Variable Transformer:			Uses POWERSTAT Enclosure:	
Series	Ganged Assemblies	Type	Type	Net Wt. Lbs. (Kg)
1156D, 1256D & 1296D	7-8-9	MB1156DU-7, -8, -9; MB1256DU-7, -8, -9; MB1296DU-7, -8, -9	PBA50-N01-F	280 (127.0)
		Open Delta & Series Parallel Types:		
	10-12	MB1156DU-10, -12; MB1256DU-10, -12; MB1296DU-10, -12	PBA50-N01-EE	550 (249.5)
	14-16	MB1156DU-14, -16; MB1256DU-14, -16; MB1296DU-14, -16	PBA50-N01-FF	650 (294.8)
	18	MB1156DU-18, MB1256DU-18, MB1296DU-18	PBA50-N01-GG	720 (326.6)
		Wye Types:		
	12	MB1156DU-12, MB1256DU-12, MB1296DU-12	PBA50-N01-DD	500 (226.8)
15-18	MB1156DU-15, -18; MB1256DU-15, -18; MB1296DU-15, -18	PBA50-N01-EE	550 (249.5)	
21-24	MB1156DU-21, -24; MB1256DU-21, -24; MB1296DU-21, -24	PBA50-N01-FF	650 (294.8)	
27	MB1156DU-27, MB1256DU-27, MB1296DU-27	PBA50-N01-GG	720 (326.6)	

PBA10, PBA30 & PBA40 Series Outline Dimensions

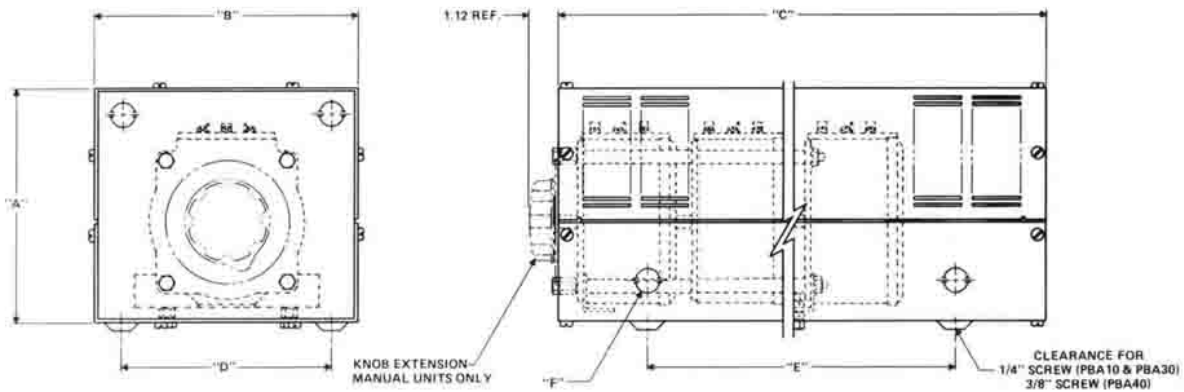

Manually Operated

Concentric Knockouts "F"

Type	Quantity	Diameter: Inches (Millimeters)
PBA10-N01-1	12	.88 (22.3)
PBA10-N01-2	14	
PBA10-N01-3	14	
PBA10-N01-4	14	
PBA30-N01-1	8	.88 (22.3)
PBA30-N01-2	8	
PBA30-N01-3	8	
PBA30-N01-4	8	
PBA40-N01-1	6	.88 (22.3) & 1.12 (28.5)
PBA40-N01-2	8	
PBA40-N01-3	8	
PBA40-N01-4	8	

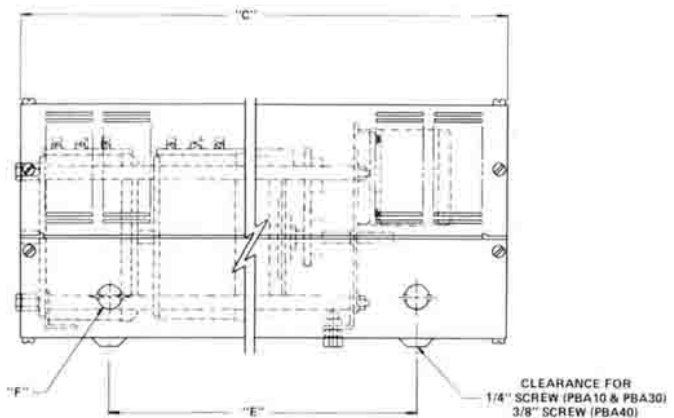

Motor Driven

Type	Dimension				
	"A"	"B"	"C"	"D"	"E"
PBA10-N01-1	7.00 (177.80)	8.00 (203.20)	6.00 (152.40)	6.25 (158.75)	4.00 (101.60)
PBA10-N01-2	7.00 (177.80)	8.00 (203.20)	13.00 (330.20)	6.25 (158.75)	9.00 (228.60)
PBA10-N01-3	7.00 (177.80)	8.00 (203.20)	18.00 (457.20)	6.25 (158.75)	14.00 (355.60)
PBA10-N01-4	7.00 (177.80)	8.00 (203.20)	25.00 (635.00)	6.25 (158.75)	21.00 (533.40)

PBA30-N01-1	10.12 (257.05)	9.25 (234.95)	6.25 (158.75)	7.62 (193.55)	4.25 (107.95)
PBA30-N01-2	10.12 (257.05)	9.25 (234.95)	14.00 (355.60)	7.62 (193.55)	7.00 (177.80)
PBA30-N01-3	10.12 (257.05)	9.25 (234.95)	19.00 (482.60)	7.62 (193.55)	12.00 (304.80)
PBA30-N01-4	10.12 (257.05)	9.25 (234.95)	25.00 (635.00)	7.62 (193.55)	18.00 (457.20)

PBA40-N01-1	12.88 (327.15)	11.88 (301.75)	6.25 (158.75)	10.25 (260.35)	4.25 (107.95)
PBA40-N01-2	12.88 (327.15)	11.88 (301.75)	14.00 (355.60)	10.25 (260.35)	7.00 (177.80)
PBA40-N01-3	12.88 (327.15)	11.88 (301.75)	19.00 (482.60)	10.25 (260.35)	12.00 (304.80)
PBA40-N01-4	12.88 (327.15)	11.88 (301.75)	25.00 (635.00)	10.25 (260.35)	18.00 (457.20)

PBA50 Series Outline Dimensions

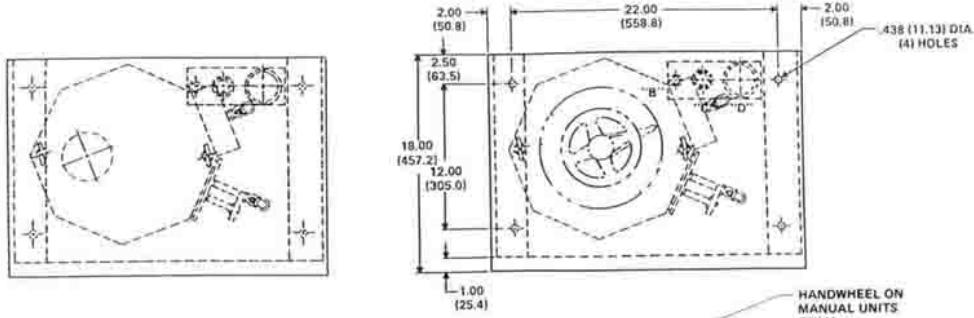

Type	Dimension "A"
PBA50-N01-A	16.25 (412.75)
PBA50-N01-B	24.25 (615.95)
PBA50-N01-C	34.25 (869.95)
PBA50-N01-D	46.25 (1174.75)
PBA50-N01-E	56.25 (1428.75)
PBA50-N01-F *	74.25 (1885.95)

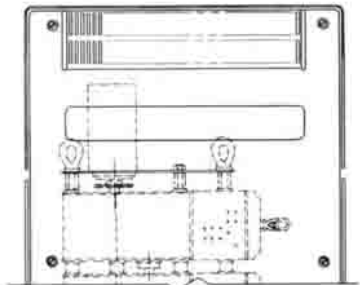

Motor Driven

Concentric Knockouts

Designation	Diameter: Inches (Millimeters)
"B"	.88 (22.3) & 1.12 (28.5)
"C"	1.38 (35.0), 1.75 (44.5) & 2.00 (50.8)
"D"	2.50 (63.5) & 3.00 (76.2)

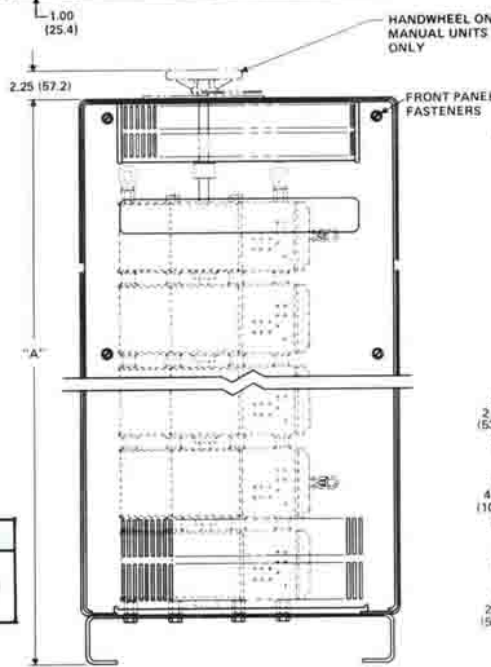

Manually Operated

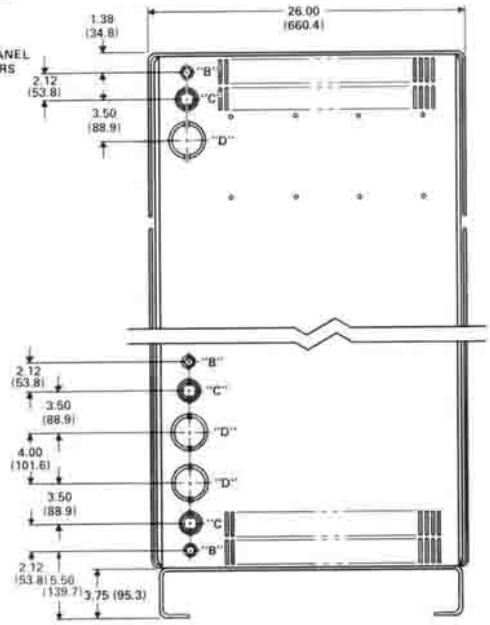

* Motorized units only.

***NOTE:** These enclosures are only available as factory installed options for motor driven POWERSTAT Variable Transformers.

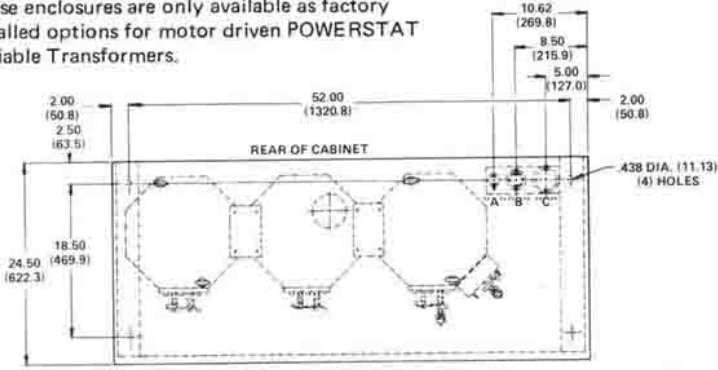

Type	Dimension "A"
PBA50-N01-DD *	46.25 (1174.75)
PBA50-N01-EE *	56.25 (1428.75)
PBA50-N01-FF *	74.25 (1885.95)
PBA50-N01-GG *	88.25 (2241.55)

Concentric Knockouts

Designation	Diameter: Inches (Millimeters)
"A"	.88 (22.3) & 1.12 (28.5)
"B"	1.38 (35.0), 1.75 (44.5) & 2.00 (50.8)
"C"	2.50 (63.5) & 3.00 (76.2)

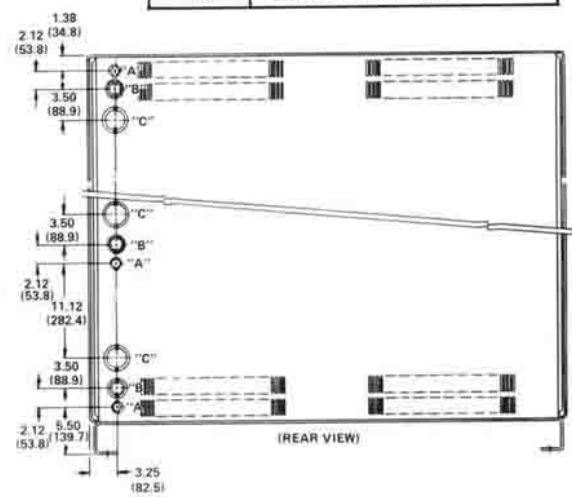
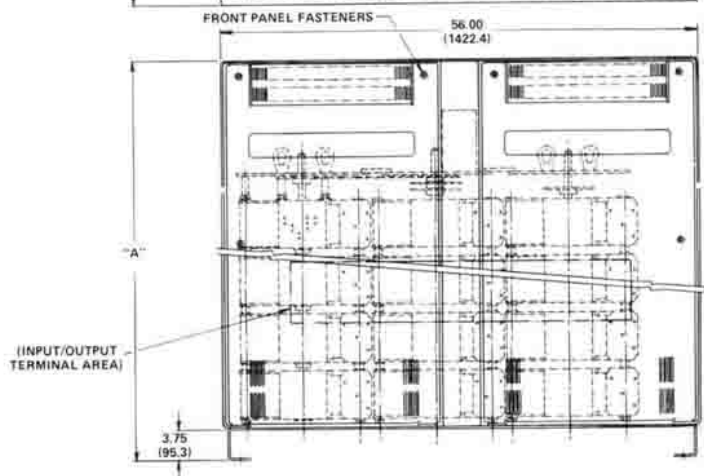

(REAR VIEW)

Distribution Coast-to-Coast and International

Superior Electric products are available worldwide through an extensive authorized distributor network. These distributors offer literature, technical assistance and a wide range of models off the shelf for fastest possible delivery and service.

In addition, Superior Electric sales representatives are available to provide prompt attention to customer needs. Call or fax for ordering and application information or for the name and address of the nearest authorized distributor.

383 Middle Street
Bristol, CT 06010 USA
Tel: 860-585-4500
Fax: 860-582-3784
Web: www.superiorelectric.com

Toll Free in USA and Canada

Customer Service: 1-800-787-3532 - Ext. 4750
Product Application: 1-800-787-3532 - Ext. 4755
Product Literature Requests: 1-800-787-3532 - Ext. 4750
Fax: 1-800-821-1369

Superior
Electric

383 Middle Street • Bristol, CT 06010 USA
Tel: 860.585.4500 • Fax: 860.584.1483



Printed in USA