

Superior Electric

VOLTAGE REGULATION • LIGHTING CONTROL • SPEED CONTROL • POWER SUPPLIES

1296D Series POWERSTAT® Variable Transformers *Including Drives, Enclosures and Controls*

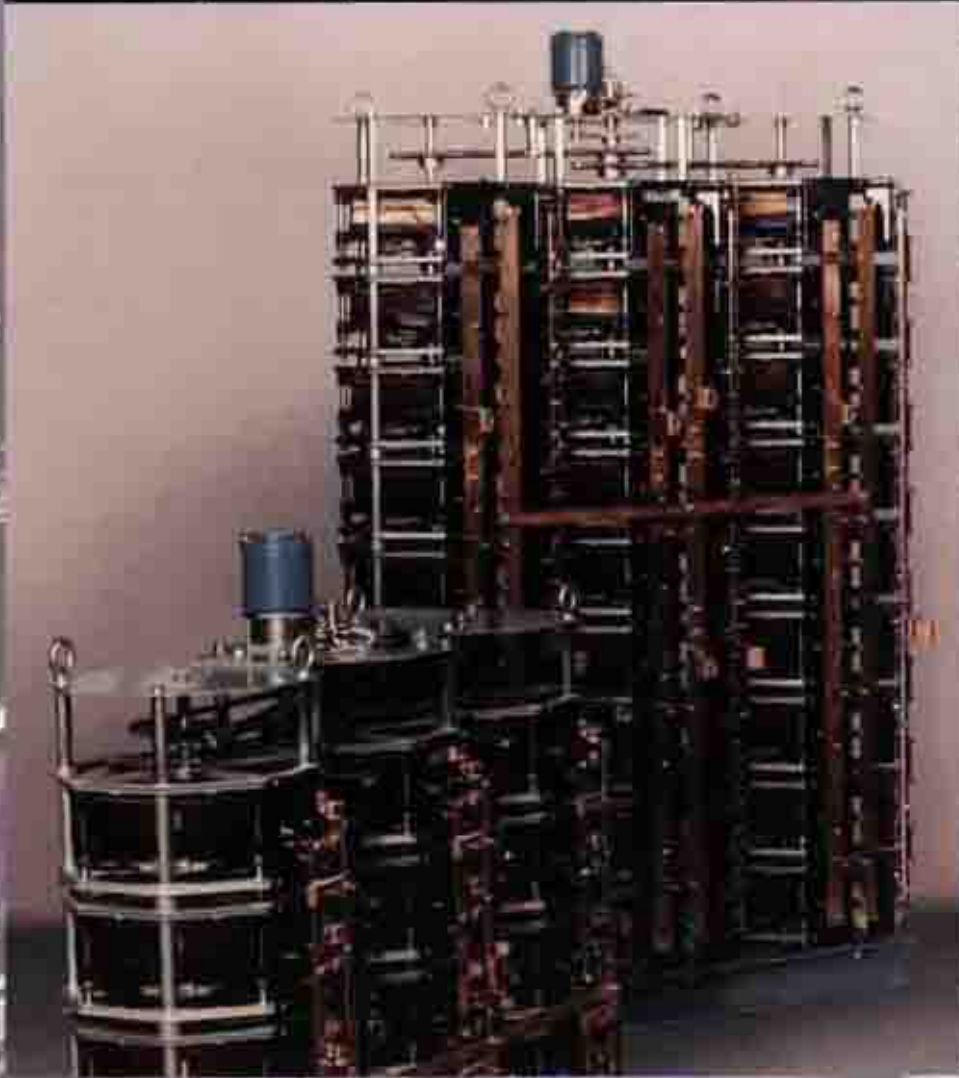

PROCESS HEATING CONTROL • MOTOR TESTING • LOAD BANKS • VIBRATORY FEEDERS

POWER CONDITIONING • VOLTAGE REGULATORS • LIGHTING CONTROLS • UPS SYSTEMS • TVSS • MOTION CONTROLS

New 1296D Series **POWERSTAT**® Variable Transformers ...for the adjustment and control of electrical power

The 1296D Series is the newest product offering in Warner Electric's POWERSTAT Variable Transformer family. This new high power frame size consists of 534 standard catalog models. While the physical size of the 1296D Series remains the same as the 1256D Series, the power ratings have increased up to 40 percent.

Warner Electric has been manufacturing POWERSTAT Variable Transformers since 1938. Their reliability, durability and quality together with the company's com-

mitment to customer service have established Warner Electric as the industry leader. POWERSTAT Variable Transformers are available worldwide through an extensive network of authorized stocking distributors.

For application assistance or to request a special POWERSTAT Variable Transformer version, telephone toll-free:

Customer Service: 1-800-787-3532, Ext. 4750

Product Application: 1-800-787-3532, Ext. 4755

Contents

	<i>Page</i>
POWERSTAT Variable Transformer Description	3
POWERSTAT Variable Transformer/SCR Comparison	4
Connection Terminology	4
Basic Configuration	5
Current Rating Terminology	5
Selection	6-7
Type Number Designations	7
Drive Options	8-9
Enclosure Options	10-11
Ratings & Connections	12-15
Specifications	16
Weights	17
Outline Dimensions	
POWERSTAT Variable Transformers	18-21
NEMA I Enclosures	22
Controls	
POWERSTAT Positioner Controller Type PD120B	23
STABILINE Full Range Regulator Controllers	24-26

What is a POWERSTAT Variable Transformer?

POWERSTAT Variable Transformers provide a simple, rugged method of controlling electrical voltage, current and power. They take in utility line voltage and provide continuously adjustable output voltage. A wide range of sizes, drives, enclosures and controls are offered.

Standard fixed ratio transformers have output terminals

connected to a particular turn to provide a given output voltage. Instead of a fixed connection to a particular turn, POWERSTAT Variable Transformers utilize a brush riding on a commutator formed as part of the transformer turns. The user can select any output turn and thereby vary the output voltage. Because they are autotransformers, one winding acts as both primary and secondary.

Features

- Rugged Construction
- Smooth Linear Control of Output Voltage
- Low Resistance, High Efficiency Coils
- No Waveform Distortion
- High Overload Capacity
- Very Durable and Reliable
- Easy to Select, Install and Control
- UL Recognized
- CSA Certified

Applications

- Regulate Voltage
- Speed Control
- Lighting Control
- Motor Test Stands
- Power Supplies
- Industrial Process Heating Control
- Source Voltage & Load Banks for Electrical Testing:
 - Circuit Breaker
 - Uninterruptible Power Supplies
 - Generators

Advanced engineering, the finest materials and quality production have been combined to make the 1296D Series the highest power, most efficient POWERSTAT Variable Transformer available.

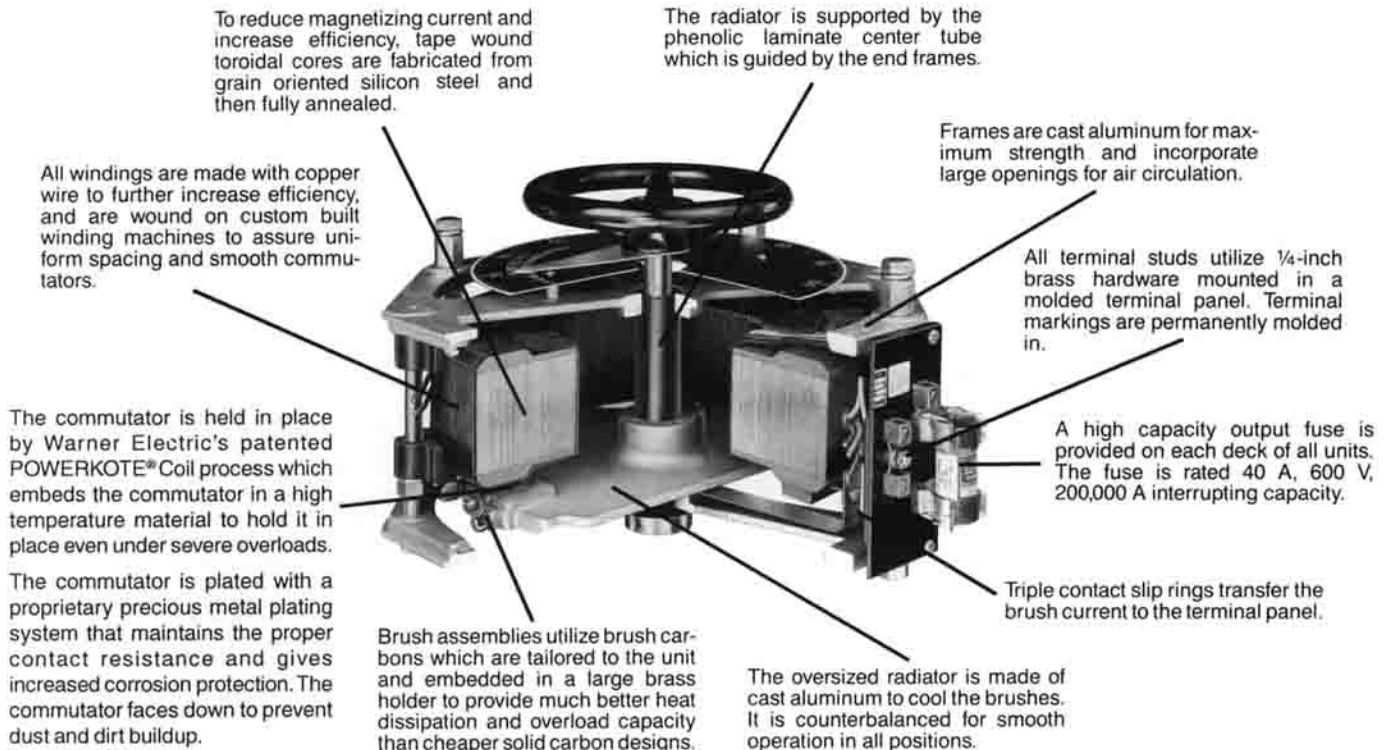

Why are POWERSTAT Variable Transformers better than SCR solid state controllers?

POWERSTAT Variable Transformers

SCR Solid State Controllers

POWERSTAT Variable Transformers produce an adjustable output voltage that is a sine wave. Only the voltage magnitude is changed; the shape of the voltage is not distorted.

SCR controllers produce a highly distorted voltage waveform. To vary the output power, each half cycle SCRs start the voltage at different points on the sine wave and turn the power off when the current drops to zero.

Do not produce harmonic distortion.
Reduce utility bills.
Avoid interference with other equipment.

Generate harmonic distortion which is fed back into the power system and can overheat distribution transformers, interfere with the operation of other equipment and reduce the torque of motors on the power system.

Handle all load power factors.
Can be used to adjust banks of capacitors and/or inductors.

Because SCRs commonly turn on with voltage and off with current, they can have difficulty handling lower power factor loads. SCR controllers are rated only for loads with certain power factors.

Easy to control with simple raise-lower switches or standard process controllers. Motor drive control provides complete isolation between power and control circuits and POWERSTAT units are immune to power line noise.

Require complicated electronic drive circuits and control circuits. Circuits can be damaged by transients on the power line. Power line and load current transients can cause false operation of the SCRs.

Connection Terminology

To allow the standard POWERSTAT Variable Transformer to fulfill most requirements, the input voltage to these units can be connected in one of three ways:

“Line” Connection: The input voltage is connected to the POWERSTAT unit so that the maximum output voltage equals the input voltage.

“Boost” Connection: The input voltage is connected to the POWERSTAT unit so that the maximum output voltage is 17 percent above the input voltage.

“Step-Up” Connection: Each deck of a 1296D Series unit has a low voltage input tap that permits operation from a 120 V input to obtain an output voltage of 0-280 V.

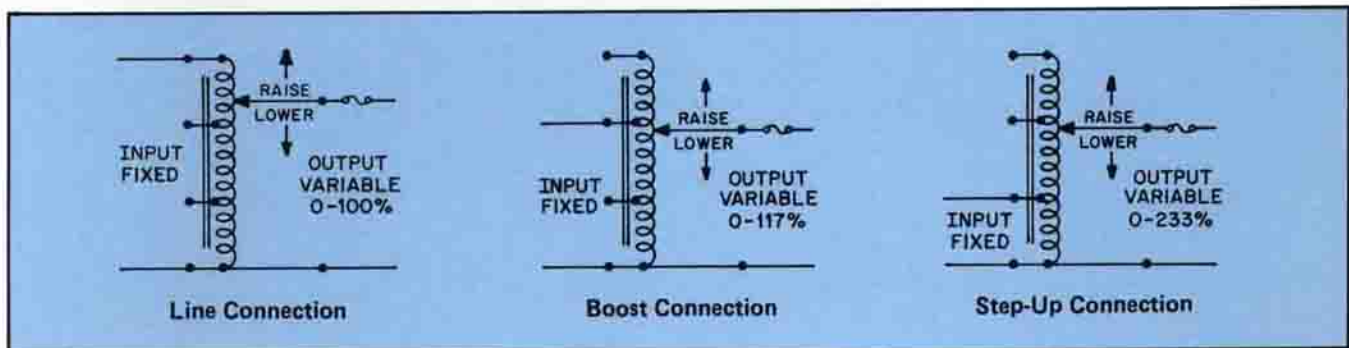

Basic Configuration

The basic POWERSTAT Variable Transformer "deck" is a single coil variable transformer assembly which is used as the building block for all 1296D units. It is typically connected to deliver any output voltage between zero and 17 percent above the input voltage and is nominally rated for 240 V, 50/60 Hz, 277 V, 60 Hz, 35 A constant current, 39 A constant impedance. These building blocks are combined to make the following range of cataloged voltage and kVA power ratings:

Voltage	Connection	KVA
208 × 240	1 Phase	8-88
400 × 480 × 600	1 Phase Series	14-211
208 × 240	3 Phase Open Delta	15-153
400 × 480 × 600	3 Phase Wye	24-365

Basic decks are wired in parallel to build the higher power ratings. Two decks have double the load current and power rating, three decks triple the rating, etc. The individual decks are stacked on top of each other, bolted together and operated from a common shaft. When individual decks are wired in parallel, paralleling chokes are added to the assembly. The purpose of these small 1:1 transformers is to ensure the total load current is divided equally between all paralleled decks.

All 1296D Series POWERSTAT assemblies are completely self-contained. They are fully assembled and include all required paralleling chokes and connections, input and output terminals for copper wire, bases, shafts, lifting eyes and output fuses.

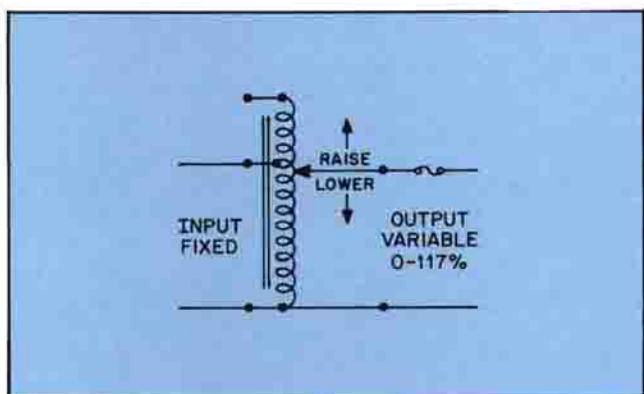

Units with 208 × 240 V, single phase ratings utilize one or more decks connected in parallel.

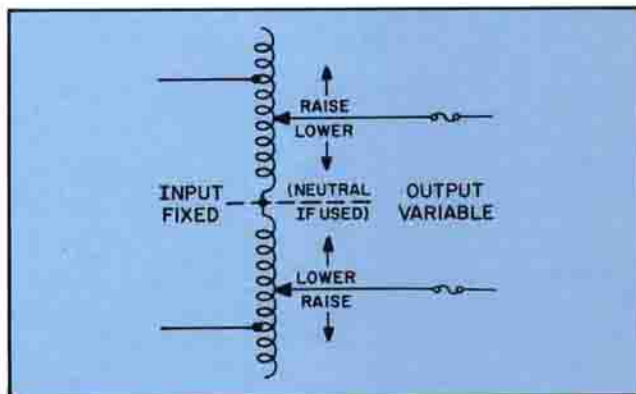

Units with 400 × 480 × 600 V, single phase ratings utilize two decks (or two paralleled banks of decks) connected in series.

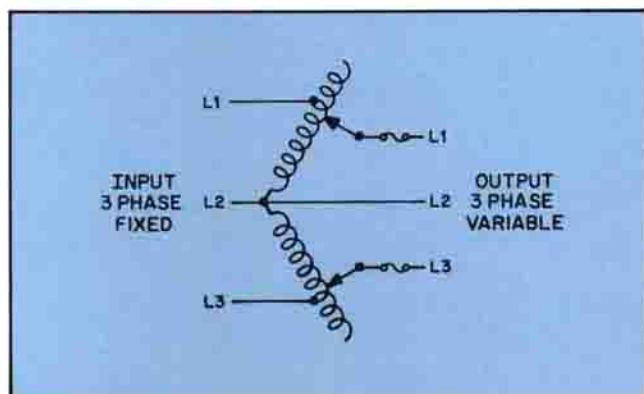

Units with 208 × 240 V, three phase ratings utilize two decks (or two paralleled banks of decks) connected in open delta.

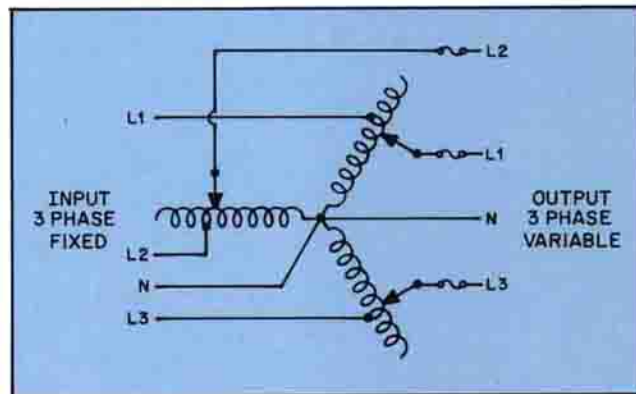

Units with 400 × 480 × 600 V, three phase ratings utilize three decks (or three paralleled banks of decks) in a wye connection.

Current Rating Terminology

To permit maximum utilization of POWERSTAT Variable Transformers, output ratings are given for both constant current and constant impedance loads.

Constant Current Rating: Maximum output current that can be carried regardless of output voltage setting.

Constant Impedance Rating: Maximum output current produced by loads such as incandescent lamps or resistance heaters in which the current drawn is approximately proportional to the applied voltage. This rating applies only when the POWERSTAT unit is line connected.

Selection

The Customer Service staff at Warner Electric will be pleased to share with you its extensive experience in the application and use of POWERSTAT Variable Transformers. Special units are regularly built to meet

specific customer requirements. Units with power ratings higher than cataloged are available also. Please contact Warner Electric for application assistance, price and delivery information.

To select a POWERSTAT Variable Transformer:

1. Determine the nominal voltage, frequency and phase of the input power to the POWERSTAT Variable Transformer. Systems are typically a combination of the following:
 - Voltage: 120, 208, 240, 400, 480, 600
 - Frequency: 50 Hz, 60 Hz
 - Phases: Single Phase – Line to Neutral
Single Phase – Line to Line
Three Phase – Delta Connected
Three Phase – Wye Connected
 2. Determine the voltage range the POWERSTAT unit is to deliver to the load:
 - Line Connection
 - Boost Connection
 - Step-Up Connection
 3. Determine the current or kVA that must be delivered to the load by the POWERSTAT unit. The current or power drawn by any particular electrical device can be found on its nameplate, measured with an ammeter or can be calculated. If the load draws repetitive bursts of current or draws very heavy current while starting (some motors), the maximum current, the length of time and how often this current is drawn should be available.
 4. Select the drive option (see pages 8-9):
 - Manual (1-9 decks)
 - Synchronous Motor Drive (1-27 decks)
 - Digital Motor Drive (1-6 decks)
 5. Select the enclosure option (see pages 10-11):
 - Open Construction
 - Screened
 - Terminal Enclosure and Screens
 - NEMA 1 Enclosure
 6. Select the POWERSTAT unit from the rating charts on pages 12-15. For units mounted in NEMA I enclosures, find the equivalent open construction unit (U Suffix) in the rating charts and replace the U suffix with N01.
 7. If applicable, compare any short term overload currents with the load curve on the facing page. Select a larger unit if the overload rating of the unit is insufficient.
- Consult pages 23-26 if a controller for your synchronous motor driven POWERSTAT unit is needed.



Type 60MB1296DN01-24Y (Front Covers Removed)

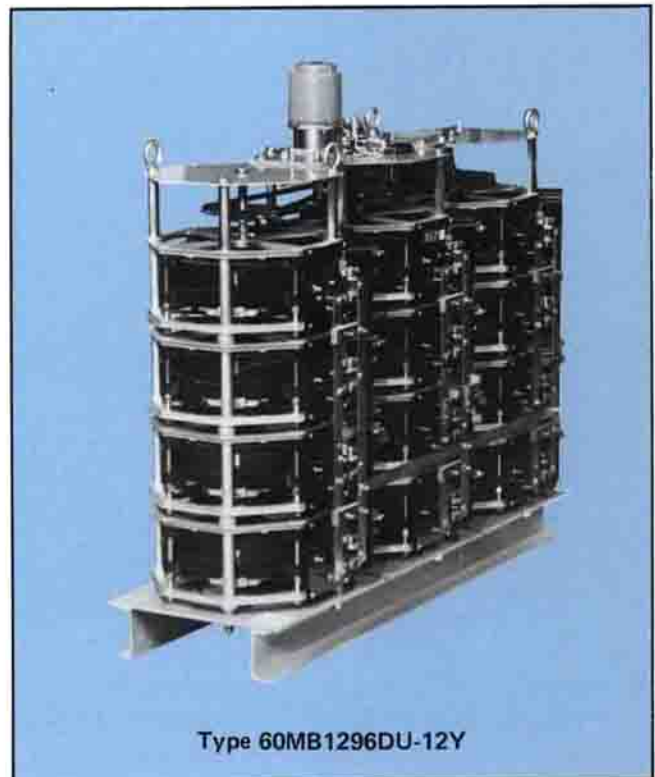

Type 60MB1296DU-12Y

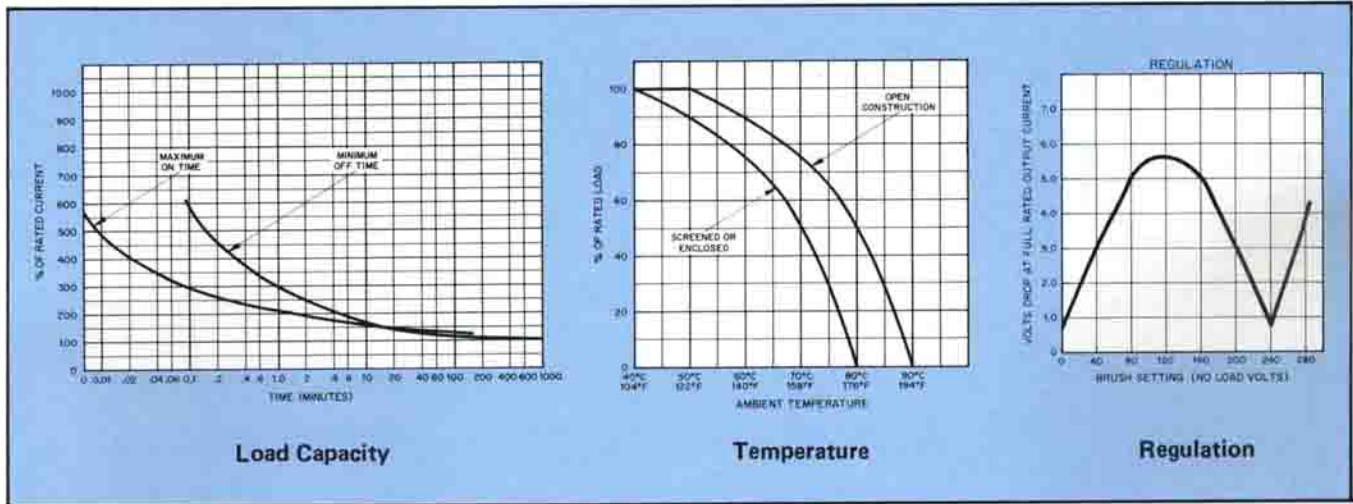

Load Capacity

POWERSTAT Variable Transformers can safely handle many overloads because of their conservative ratings and use of POWERKOTE Coils. The "ON" curve above shows the maximum time the units can be subjected to various repetitive loads. The units must be allowed sufficient "OFF" time to prevent excessive temperature buildup. Where the "ON" time desired for a repetitive load is less than the maximum shown, the "OFF" time can be reduced in accordance with the following equation:

$$\frac{\text{"OFF" Time}}{\text{"ON" Time}} = \left(\frac{\text{Overload Current}}{\text{Rated Current}} \right)^{-2}$$

Temperature

Ratings given in this catalog are for operation in ambient temperatures of -20°C to $+50^{\circ}\text{C}$ for open units and -20°C to $+40^{\circ}\text{C}$ for screened or enclosed units. When operation is required in higher ambient temperatures the output current must be reduced according to the curve shown above. Additional ratings for altitude, humidity, etc. are listed under the "Environmental Ratings" section of this catalog.

Regulation

The curve above shows the voltage drop at any brush setting when full rated load is applied. For less than full load the voltage drop is proportional to the load.

Type Number Designations

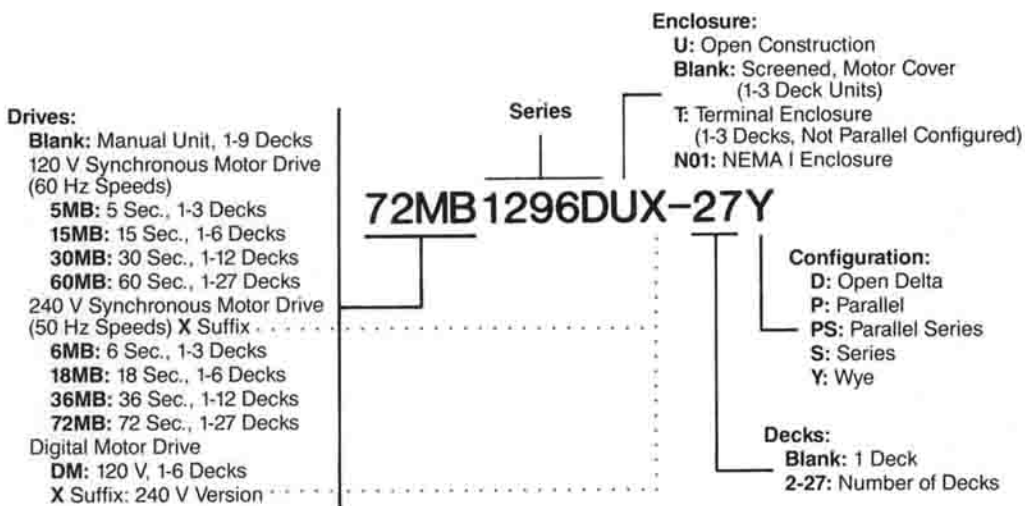

Drive Options



Manually Operated

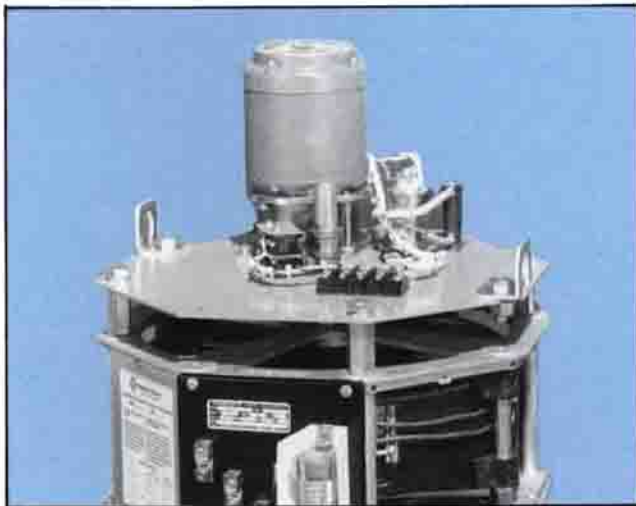

Synchronous Motor Drive

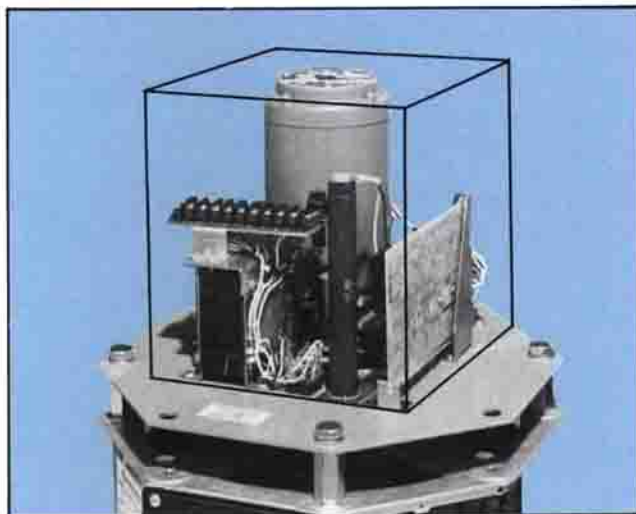

Digital Motor Drive

POWERSTAT Variable Transformers offer three ways to adjust the output voltage. The type number prefix indicates the kind of drive selected. Refer to the Type Number Designation Chart on page 7 or the Ratings Chart for details.

Manually Operated:

Single through nine deck units can be ordered with a hand wheel for manual adjustment.

Synchronous Motor Drive:

1296D Series units can be purchased with a 120 V, 60 or 50 Hz, or 240 V, 50 or 60 Hz synchronous motor drive. Depending on the number of decks, the nominal speeds for full range travel are:

120 V, 60 Hz Motor Drives

Decks	Available Speeds
1, 2, 3	5, 15, 30, 60
4, 5, 6	15, 30, 60
7 through 12	30, 60
14 and up	60

240 V, 50 Hz Motor Drives

Decks	Available Speeds
1, 2, 3	6, 18, 36, 72
4, 5, 6	18, 36, 72
7 through 12	36, 72
14 and up	72

Limit switches at the upper and lower limits of variable transformer travel prevent overtravel. The limit switches can be adjusted to limit the output voltage range if desired. Synchronous motor drives draw approximately 0.5A.

Any of the following can be used to operate the motor drive in manual or automatic control modes:

- Momentary contact raise-lower switch
- Relay contacts
- Positioner System PD120B
(See page 23)
- STABILINE Full Range Regulator Controller
(See pages 24-26)

A variety of commercially available circuits

A momentary contact raise-lower switch Type 014096-000 is available as an accessory. It is supplied with an indicator plate and mounts in a standard 2-inch deep switch box. Any standard switch plate can be used. The switch must be listed as a separate item on the purchase order.

Ordinarily one switch is used to operate each POWERSTAT unit synchronous drive. If desired, additional switches can be used to permit the control of a motor-driven POWERSTAT unit from any of several locations. Master control of two or more motor-driven units is also possible by using relays or multiple pole switches.

Digital Motor Drive:

This option provides a stepper motor and solid state drive combination to adjust the output voltage of a POWERSTAT Variable Transformer. It is available on single through six deck units. Depending on the model ordered, digital motor drives operate from either 120 V or 240 V, single phase service with frequencies of 50, 60 or 400 Hz. Limit switches at the upper and lower limits of variable transformer travel prevent overtravel.

The digital motor drive can be controlled in two ways and control connections require low-voltage wiring only.

Adjustable Speed Mode:

A separate potentiometer and raise-lower contact are used to control the speed and direction of the digital drive. The speed of the motor is controlled with a user supplied 500 k ohm, 1/2 watt reverse taper potentiometer to provide any speed from 5 to 200 seconds for full range travel of the POWERSTAT unit.

Adjustable Speed Control Type 065455-001 is an accessory which provides the switch and potentiometer required to operate the digital drive in the adjustable speed mode. It is supplied with an indicator plate and mounts in a standard 2-inch deep switch box. The control must be listed as a separate item on the purchase order if desired.

Digital Control Mode:

User supplied logic level digital pulses are used to control the speed and position of the motor drive. Pulses can be programmed to proportionally increase or decrease the output voltage of these POWERSTAT units with a resolution of 0.75 V maximum. Approximately 1200 pulses are

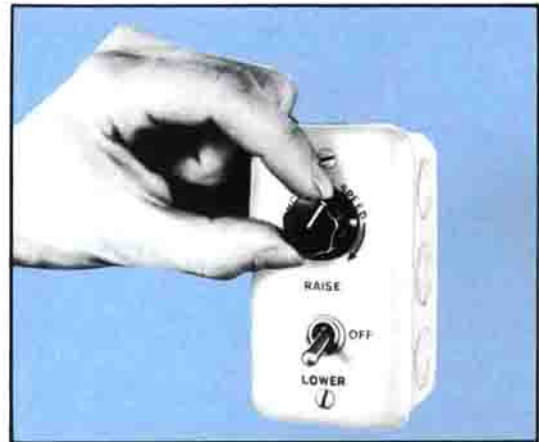

Adjustable Speed Control Type 065455-001

required to drive the POWERSTAT unit over the full range. Maximum speed is 250 pulses per second.

The motor drive is triggered by a change in voltage from logic level 1 to logic level 0 applied to the proper pulse input terminal (CW or CCW). Specifications for the trigger pulses are:

Logic Level 1	2.4 VDC to 5.5 VDC
Logic Level 0	0 VDC to 0.4 VDC
Minimum Pulse Width	10 Microseconds
Maximum Fall Time	1 Microsecond
Maximum Rise Time	10 Microseconds
Loading	5 Milliamps Max.

(With an open collector TTL device, a 4.7K ohm $\pm 10\%$ pull-up resistor to 5 V is required.)

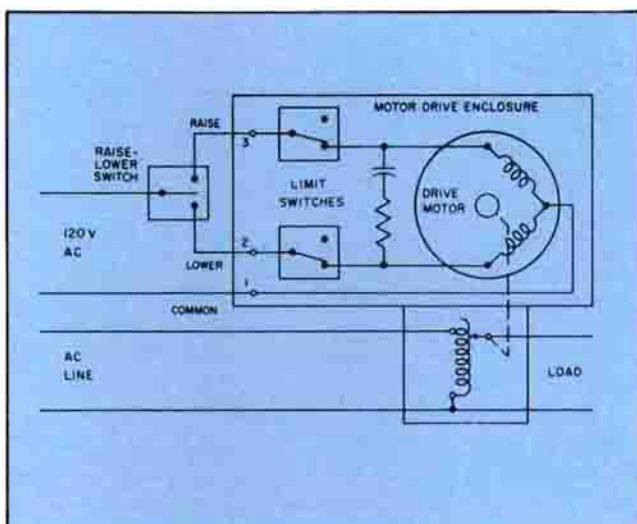

Synchronous Motor Drive Circuit Diagram

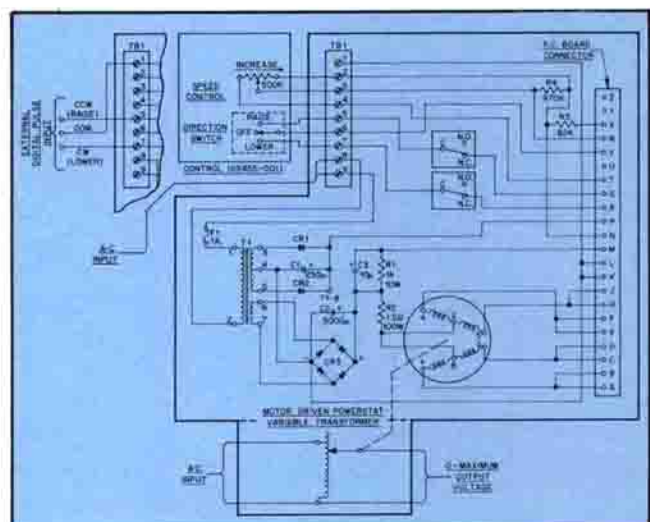

Digital Motor Drive Circuit Diagram

Enclosure Options



Open Construction



Screened

Terminal Enclosure & Screens

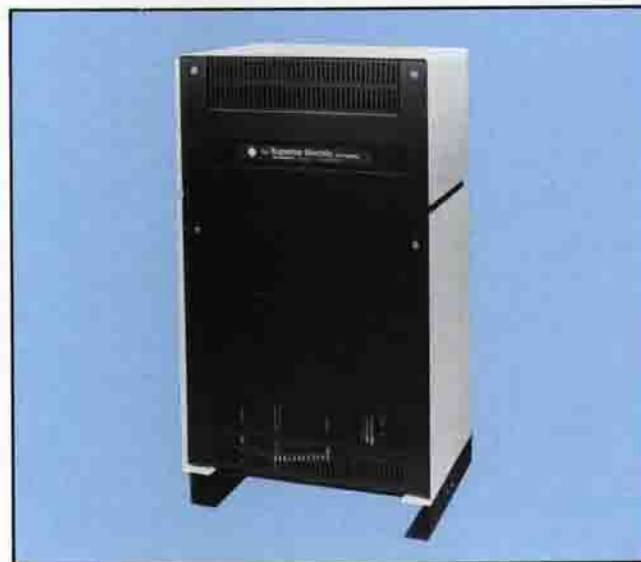

NEMA I Enclosure

Open Construction:

All 1296D Series POWERSTAT Variable Transformers are available without screens or enclosures. Open construction units are generally used as components which are mounted in the customer's equipment enclosure. To order, include the suffix letter U in the type number after 1296D. For example 1296DU-3Y.

Screened:

One, two and three deck units are offered with screens around the sides of the coil and covers over the motor drives. Screened units are often used mounted inside the customer's equipment enclosure. The screens provide protection for service personnel against accidental contact with the coil of the POWERSTAT unit. The uncovered terminal board allows easy wiring. Note that the ambient temperature rating for a screened unit is 10°C (18°F) less than that of an open construction unit. To order, omit the letter U in the type number. For example 1296D-3Y.

Terminal Enclosure & Screens:

With this option, the single 1296D, two deck 1296D-2S and the three deck 1296D-3Y units are furnished with screens around the sides of the coil, covers over the motor drives and terminal board enclosures. To order, substitute suffix T for the letter U in the type number. For example 1296DT-3Y.

NEMA I Enclosure:

All 1296D Series units can be provided in NEMA I, PBA Series Enclosures. These enclosures have been specifically designed to house open construction (suffix U) type POWERSTAT Variable Transformers. They are constructed of heavy gauge sheet metal and are supplied completely assembled. A full range of knockouts and all required hardware is included.

PBA Series Enclosures are NEMA Type 1 as defined in NEMA Standard ICS 1-110. As such they are designed to protect users against accidental contact with the enclosed POWERSTAT Variable Transformer. They are intended for use indoors in areas where unusual service conditions do not exist.

Enclosures for single through six deck 1296DU Series open construction POWERSTAT units may be ordered as separate field installed items or factory installed. The separate field installed enclosure comes with all required mounting hardware, shaft extensions, etc.

Enclosures for motor-driven 1296DU Series POWERSTAT Variable Transformers with more than six decks are

available as factory installed options only. Factory installation is required because of the size of the units and the need to provide fans of the proper size and voltage to prevent heat buildup.

Seven, eight and nine deck manual units are not offered in the NEMA I enclosure. They would fit in the PBA50-N01-F enclosure but the hand wheel on top of the enclosure would be too high to be easily operated. Motorized versions of these units are available in the NEMA I enclosure.

The type numbers of the separate enclosures for the single through six deck POWERSTAT units are shown in the Enclosure Selection Chart. The type numbers for the larger enclosures are not offered as separate items; they are included for reference only. To order a POWERSTAT Variable Transformer installed in an enclosure, substitute suffix N01 for the letter U in the type number. For example 60MB1296DN01-12Y.

All single door, floor mounted enclosures can be fitted with optional Caster Kit 218832-001.

To accommodate special customer requirements, POWERSTAT Variable Transformers can be installed in larger enclosures. The factory invites questions regarding modification of enclosures.

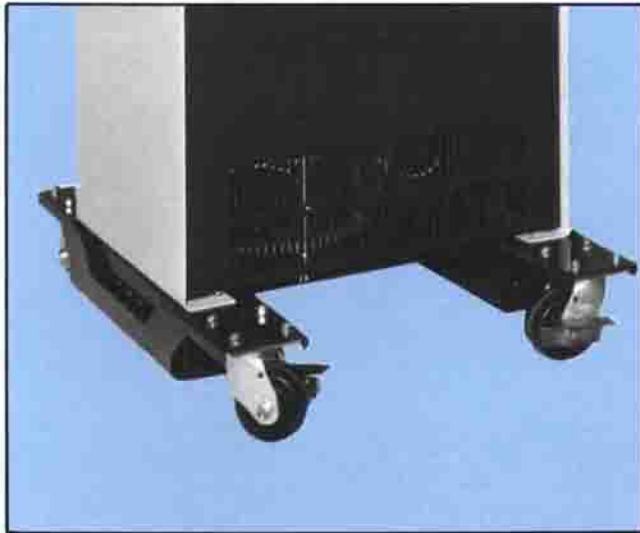

PBA50 Series Enclosure with Caster Kit 218832-001

MANUAL UNITS

Decks	Type Number Of Enclosure Only	Approximate Net Weight Of Enclosure Only	
		Lbs	Kg
1	PBA50-N01-A	100	45
2	PBA50-N01-B	130	59
3	PBA50-N01-C	160	73
4	PBA50-N01-D	190	86
5	PBA50-N01-D	190	86
6	PBA50-N01-E	220	100

MOTORIZED UNITS

Decks/ Configuration	Type Number Of Enclosure Only	Approximate Net Weight Of Enclosure Only	
		Lbs	Kg
1	PBA50-N01-B	130	59
2	PBA50-N01-C	160	73
3	PBA50-N01-D	190	86
4	PBA50-N01-D	190	86
5	PBA50-N01-E	220	100
6	PBA50-N01-E	220	100
7	PBA50-N01-F		
8	PBA50-N01-F		
9	PBA50-N01-F		
10	PBA50-N01-EE		
12 D & PS	PBA50-N01-EE		
12 Y	PBA50-N01-DD		
14	PBA50-N01-FF		
15	PBA50-N01-EE		
16	PBA50-N01-FF		
18 D & PS	PBA50-N01-GG		
18 Y	PBA50-N01-EE		
21	PBA50-N01-FF		
24	PBA50-N01-FF		
27	PBA50-N01-GG		

240 Volt, Single Phase Ratings & Connections

CONNECTION:	"LINE"	"BOOST"	"STEP UP"
Input Voltage: Output Voltage: Frequency (Hz):	240 0-240 50/60	240 0-280 50/60	120 0-280 50/60
TERMINALS Input: Output Single Unit: -2P Thru -9P:	1-4 1-3 1-H2	1-2 1-3 1-H2	1-5 1-3 1-H2

On units with synchronous motor drives, the model number is prefixed with one of the available nominal motor travel times (seconds) as follows:

120 V, 60 Hz Motor. Example: 60MB1296D	****	5	15	30	60
	***	NA	15	30	60
	**	NA	NA	30	60
240 V, 50 Hz Motor. Example: 36MB1296DUX-4P	####	6	18	36	72
	###	NA	18	36	72
	##	NA	NA	36	72

Constant Current Load		Constant Impedance Load		Constant Current Load		Constant Current Load		Model Number			Conn Diag
Max. Amps	Max. KVA	Max. Amps	Max. KVA	Max. Amps	Max. KVA	Max. Amps	Max. KVA	Manually Operated	Motor Driven		
									Synchronous	Digital	
35	8.4	39	9.4	35	9.8	14.7	4.1	1296DU 1296D 1296DT	**** MB1296DU **** MB1296D **** MB1296DT #### MB1296DUX #### MB1296DX #### MB1296DTX	DM1296DU DM1296D DM1296DT DM1296DUX DM1296DX DM1296DTX	1
70	17	78	19	70	20	29	8	1296DU-2P 1296D-2P	**** MB1296DU-2P **** MB1296D-2P #### MB1296DUX-2P #### MB1296DX-2P	DM1296DU-2P DM1296D-2P DM1296DUX-2P DM1296DX-2P	2
105	25	117	28	105	29	44	12	1296DU-3P 1296D-3P	**** MB1296DU-3P **** MB1296D-3P #### MB1296DUX-3P #### MB1296DX-3P	DM1296DU-3P DM1296D-3P DM1296DUX-3P DM1296DX-3P	3
140	34	156	37	140	39	59	16	1296DU-4P	*** MB1296DU-4P ### MB1296DUX-4P	DM1296DU-4P DM1296DUX-4P	3
175	42	195	47	175	49	74	21	1296DU-5P	** MB1296DU-5P ## MB1296DUX-5P	DM1296DU-5P DM1296DUX-5P	3
210	50	234	56	210	59	88	25	1296DU-6P	* MB1296DU-6P # MB1296DUX-6P	DM1296DU-6P DM1296DUX-6P	3
245	59	273	66	245	69	103	29	1296DU-7P	** MB1296DU-7P ## MB1296DUX-7P		3
280	67	312	75	280	78	118	33	1296DU-8P	** MB1296DU-8P ## MB1296DUX-8P		3
315	76	351	84	315	88	132	37	1296DU-9P	** MB1296DU-9P ## MB1296DUX-9P		3

Units are supplied with all required jumpers. Units with -4P through -9P suffixes utilize bus bar jumpers and are shipped with the input bus bar jumper connected for "Boost" operation (connected to input terminal 2). If "Line" or "Step-Up" operations is required, the input bus bar jumper must be moved to terminal 4 or 5 as required.

All output fuses (40 A, 600V) and paralleling chokes (T5587) shown in connection diagrams are provided.

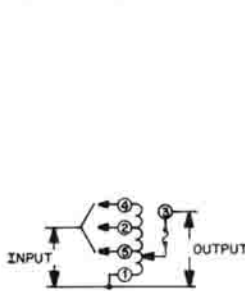

Connection 1

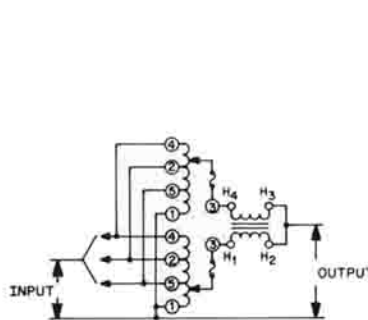

Connection 2

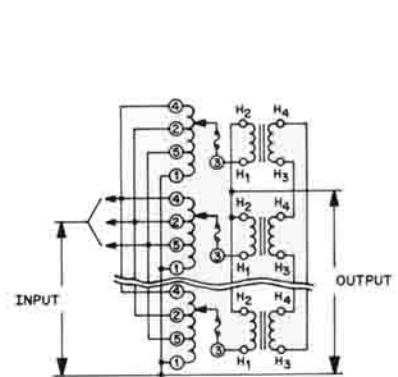

Connection 3

400, 480, 600 Volt, Single Phase Ratings & Connections

CONNECTION:	"LINE"			"BOOST"		"STEP UP"
	Input Volts: Output Volts: Frequency:	400 0-400 50/60	480 0-480 50/60	600 0-600 60	400 0-467 50/60	480 0-560 50/60
TERMINALS Input: Output: -2S Only: -6PS Thru -18PS:	4 - 4 3 - 3 H2 - H2			2 - 2 3 - 3 H2 - H2		5 - 5 3 - 3 H2 - H2

On units with synchronous motor drives, the model number is prefixed with one of the available nominal motor travel times (seconds) as follows:

120 V, 60 Hz Motor. Example: 5MB1296D-2S					
****	5	15	30	60	
***	NA	15	30	60	
**	NA	NA	30	60	
240 V, 50 Hz Motor. Example: 18MB1296DUX-2S					
####	6	18	36	72	
###	NA	18	36	72	
##	NA	NA	36	72	

Constant Current Load		Constant Impedance Load			Constant Current Load		Constant Current		Model Number			Conn Diag
Max. Amps	Max. KVA At 400 480 600	Max. Amps	Max. KVA At 400 480 600		Max. Amps	Max. KVA At 467 560	Max. Amps	KVA At 560	Manually Operated	Synchronous Motor Drive	Digital Motor Drive	
35	14 16.8 21	39	15.6 18.7 23.4	35	16.3 19.6	14.7	8.2	1296DU-2S 1296D-2S 1296DT-2S	**** MB1296DU-2S **** MB1296D-2S **** MB1296DT-2S #### MB1296DUX-2S #### MB1296DX-2S #### MB1296DTX-2S	DM1296DU-2S DM1296D-2S DM1296DT-2S DM1296DUX-2S DM1296DX-2S DM1296DTX-2S	4	
70	28 34 42	78	31 37 47	70	33 39	29	16	1296DU-4PS	*** MB1296DU-4PS ### MB1296DUX-4PS	DM1296DU-4PS DM1296DUX-4PS	5	
105	42 50 63	117	47 56 70	105	49 59	44	25	1296DU-6PS	*** MB1296DU-6PS ### MB1296DUX-6PS	DM1296DU-6PS DM1296DUX-6PS	6	
140	56 67 84	156	62 75 94	140	65 78	59	33	1296DU-8PS	** MB1296DU-8PS ## MB1296DUX-8PS			
175	70 84 105	195	78 94 117	175	82 98	74	41		** MB1296DU-10PS ## MB1296DUX-10PS		6	
210	84 101 126	234	94 112 140	210	98 118	88	49		** MB1296DU-12PS ## MB1296DUX-12PS		6	
245	98 118 147	273	109 131 164	245	114 137	103	57		60MB1296DU-14PS 72MB1296DUX-14PS		6	
280	112 134 168	312	125 150 187	280	130 157	118	66		60MB1296DU-16PS 72MB1296DUX-16PS		6	
315	126 151 189	351	140 168 211	315	147 176	132	74		60MB1296DU-18PS 72MB1296DUX-18PS		6	

Units are supplied with all required jumpers. Units with -8PS through -18PS suffixes utilize bus bar jumpers and are shipped with the input bus bar jumper connected for "Boost" operation (connected to input terminal 2). If "Line" or "Step-Up" operations is required, the input bus bar jumper must be moved to terminal 4 or 5 as required.

All output fuses (40 A, 600V) and paralleling chokes (T5587) shown in connection diagrams are provided.

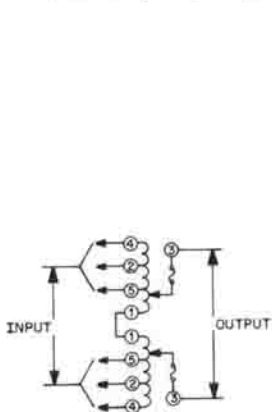

Connection 4

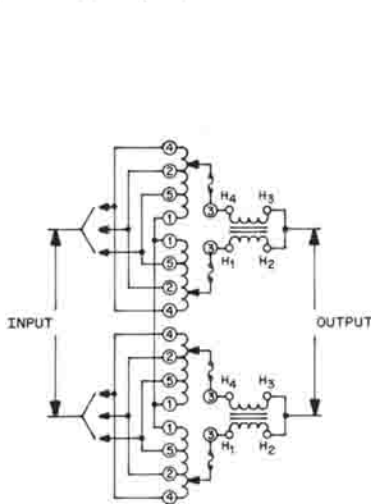

Connection 5

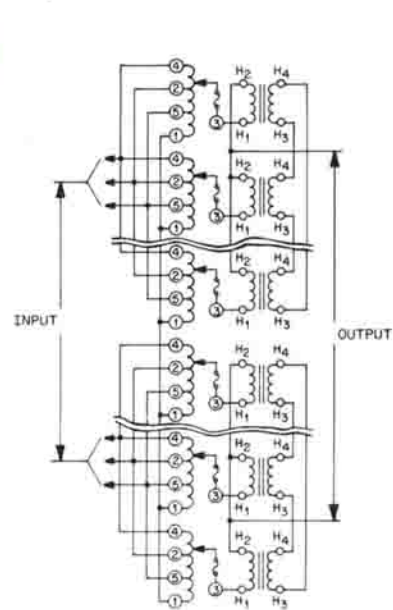

Connection 6

240 Volt, Three Phase Open Delta Ratings & Connections

CONNECTION:	"LINE"	"BOOST"	"STEP UP"
Input Voltage: Output Voltage: Frequency (Hz):	240 0-240 50/60	240 0-280 50/60	120 0-280 50/60
TERMINALS Input: Output -2D Only: -6D Thru -18D:	4 - 1 - 4 3 - 1 - 3 H2 - 1 - H2	2 - 1 - 2 3 - 1 - 3 H2 - 1 - H2	5 - 1 - 5 3 - 1 - 3 H2 - 1 - H2

On units with synchronous motor drives, the model number is prefixed with one of the available nominal motor travel times (seconds) as follows:

120 V, 60 Hz Motor. Example: 5MB1296D-2D					
****	5	15	30	60	
***	NA	15	30	60	
**	NA	NA	30	60	
240 V, 50 Hz Motor. Example: 36MB1296DUX-4D					
####	6	18	36	72	
###	NA	18	36	72	
##	NA	NA	36	72	

Constant Current Load		Constant Impedance Load		Constant Current Load		Constant Current Load		Model Number			Conn Diag
Max. Amps	Max. KVA	Max. Amps	Max. KVA	Max. Amps	Max. KVA	Max. Amps	Max. KVA	Manually Operated	Synchronous Motor Drive	Digital Motor Drive	
35	14.5	39	16.2	35	17	14.7	7.1	1296DU-2D 1296D-2D 1296DT-2D	**** MB1296DU-2D **** MB1296D-2D **** MB1296DT-2D #### MB1296DUX-2D #### MB1296DX-2D #### MB1296DX-2D	DM1296DU-2D DM1296D-2D DM1296DT-2D DM1296DUX-2D DM1296DX-2D DM1296DX-2D	7
70	29	78	32	70	34	29	14	1296DU-4D	*** MB1296DU-4D ### MB1296DUX-4D	DM1296DU-4D DM1296DUX-4D	8
105	44	117	49	105	51	44	21	1296DU-6D	** MB1296DU-6D ### MB1296DUX-6D	DM1296DU-6D DM1296DUX-6D	9
140	58	156	65	140	68	59	28	1296DU-8D	** MB1296DU-8D ## MB1296DUX-8D		9
175	73	195	81	175	85	74	36		** MB1296DU-10D ## MB1296DUX-10D		9
210	87	234	97	210	102	88	43		** MB1296DU-12D ## MB1296DUX-12D		9
245	102	273	113	245	119	103	50		60MB1296DU-14D 72MB1296DUX-14D		9
280	116	312	130	280	136	118	57		60MB1296DU-16D 72MB1296DUX-16D		9
315	131	351	146	315	153	132	64		60MB1296DU-18D 72MB1296DUX-18D		9

Units are supplied with all required jumpers. Units with -8D through -18D suffixes utilize bus bar jumpers and are shipped with the input bus bar jumper connected for "Boost" operation (connected to input terminal 2). If "Line" or "Step-Up" operations is required, the input bus bar jumper must be moved to terminal 4 or 5 as required.

All output fuses (40 A, 600V) and paralleling chokes (T5587) shown in connection diagrams provided.

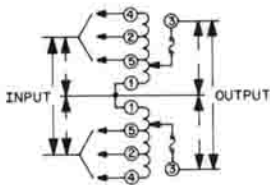

Connection 7

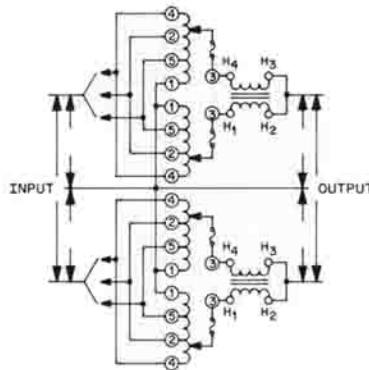

Connection 8

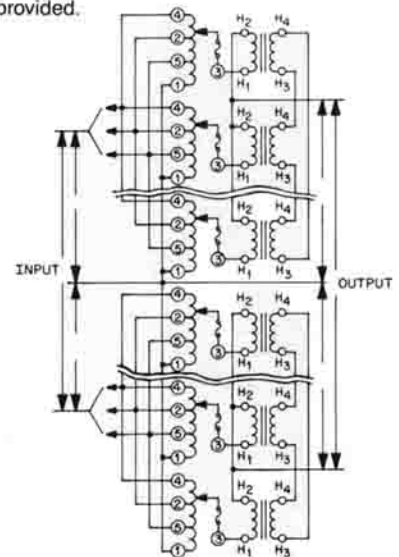

Connection 9

400, 480, 600 Volt, Three Phase Wye Ratings & Connections

CONNECTION:	"LINE"			"BOOST"		"STEP UP"
	Input Volts: Output Volts: Frequency:	400 0-400 50/60	480 0-480 50/60	600 0-600 60	400 0-467 50/60	480 0-560 60
TERMINALS Input: Output -3Y Only: -6Y Thru -27Y:	4 - 4 - 4 3 - 3 - 3 H2 - H2 - H2			2 - 2 - 2 3 - 3 - 3 H2 - H2 - H2		5 - 5 - 5 3 - 3 - 3 H2-H2-H2

On units with synchronous motor drives, the model number is prefixed with one of the available nominal motor travel times (seconds) as follows:

120 V, 60 Hz Motor. Example: 5MB1296D-3Y						
****	5	15	30	60		
***	NA	15	30	60		
**	NA	NA	30	60		
240 V, 50 Hz Motor. Example: 18MB1296DUX-9Y						
####	6	18	36	72		
###	NA	18	36	72		
##	NA	NA	36	72		

Constant Current Load		Constant Impedance Load			Constant Current Load		Constant Current		Model Number			Conn Diag				
Max. Amps	Max. KVA At			Max. Amps	Max. KVA At		Max. Amps	KVA At	Manually Operated	Synchronous Motor Drive	Digital Motor Drive					
	400	480	600		400	480						600	467	560	560	
35	24.3	29	36.4	39	27	32.4	40.5	35	28.3	34	14.7	14.3	1296DU-3Y 1296D-3Y 1296DT-3Y	**** MB1296DU-3Y **** MB1296D-3Y **** MB1296DT-3Y #### MB1296DUX-3Y #### MB1296DX-3Y #### MB1296DTX-3Y	DM1296DU-3Y DM1296D-3Y DM1296DT-3Y DM1296DUX-3Y DM1296DX-3Y DM1296DTX-3Y	10
70	49	58	73	78	54	65	81	70	57	68	29	29	1296DU-6Y	*** MB1296DU-6Y ### MB1296DUX-6Y	DM1296DU-6Y DM1296DUX-6Y	11
105	73	87	109	117	87	97	122	105	85	102	44	43	1296DU-9Y	** MB1296DU-9Y ## MB1296DUX-9Y		12
140	97	116	146	156	108	130	162	140	113	136	59	57		** MB1296DU-12Y ## MB1296DUX-12Y		12
175	122	145	182	195	135	162	203	175	142	170	74	72		60MB1296DU-15Y 72MB1296DUX-15Y		12
210	146	174	218	234	162	194	243	210	170	204	88	86		60MB1296DU-18Y 72MB1296DUX-18Y		12
245	170	203	255	273	189	227	284	245	198	238	103	100		60MB1296DU-21Y 72MB1296DUX-21Y		12
280	194	232	291	312	216	259	324	280	226	272	118	114		60MB1296DU-24Y 72MB1296DUX-24Y		12
315	219	261	328	351	243	292	365	315	255	306	132	129		60MB1296DU-27Y 72MB1296DUX-27Y		12

Units are supplied with all required jumpers. Units with -12Y through -27Y suffixes utilize bus bar jumpers and are shipped with the input bus bar jumper connected for "Boost" operation (connected to input terminal 2). If "Line" or "Step-Up" operations is required, the input bus bar jumper must be moved to terminal 4 or 5 as required.

All output fuses (40 A, 600V) and paralleling chokes (T5587) shown in connection diagrams are provided.

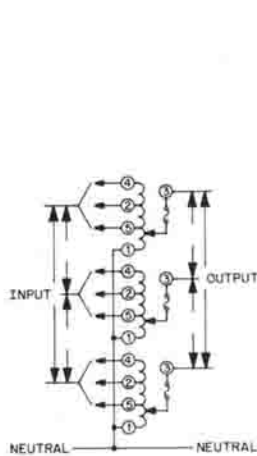

Connection 10

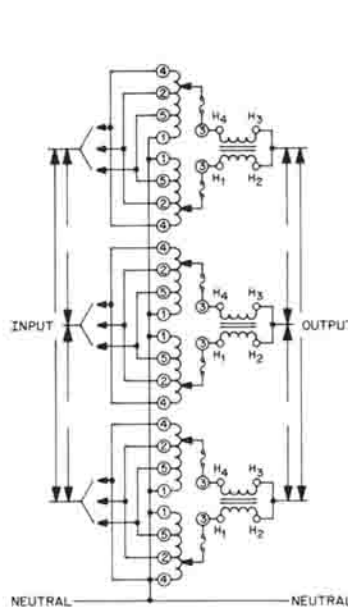

Connection 11

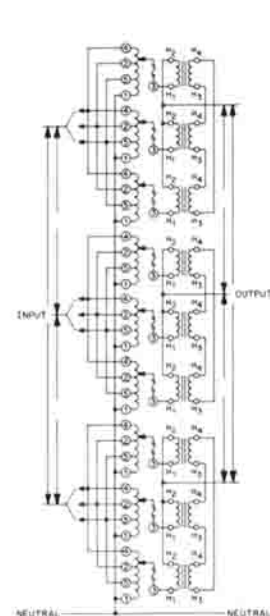

Connection 12

Specifications

Electrical

Input Voltage (max. nominal per deck)		
	@ 60 Hz	@ 50 Hz
Line Connection	346 V	277 V
Boost Connection	277 V	240 V
Step-Up Connection	138 V	120 V
Output Voltage (percent of input voltage)		
Line Connection	0 to 100%	
Boost Connection	0 to 117%	
Step-Up Connection	0 to 233%	
Tolerance All Connections	± 1.5%	
Load Current (max. per deck)		
Line Connection		
Constant Impedance	39 A	
Constant Current	35 A	
Boost Connection		
Constant Current	35 A	
Step-Up Connection		
Constant Current	14.7 A	
Load Capacity (limited by output fuse)		
See page 7 for complete curve.		
100% Load	Continuous	
300% Load	6 Sec On, 50 Sec Off	
500% Load	0.5 Sec On, 12 Sec Off	
Efficiency (varies with brush setting)		
At Full Load	98% Typical	
Exciting Current (each deck)	190 mA Typical	
Exciting Power (per deck)	46 W Typical	
BTU Produced	512 BTU/Hr Each Coil Typical	
Leakage Resistance		
100 Meg Ohms		
Minimum resistance winding to frame and shaft, at a potential of 500 volts DC, temperature between 20°C - 30°C, and relative humidity less than 50%		
Inrush Current	900 A Max.	
Peak current, one deck at maximum nominal voltage		
Distortion (added)		
Total Harmonic Distortion	0.25% Max.	
Load Regulation (worst position)		
See page 7 for complete curve.	3% Typical	
Output Fuse (Each Deck)	40 A, 600 V	
Coil Resistance (per deck at 20°C)	0.265 Ohms ± 10%	
Commutator Bars	376	

Independent Certification

UL Recognition and CSA Certification of all basic 1296D Series units with any options. When ordered in the NEMA I enclosure, only the POWERSTAT unit is approved.

Replacement Brush

RB1296D

Mechanical

Weight	(Page 17)
Weight Per Deck	75 Lbs Typical
Driving Torque Per Deck	125 Oz-In Typical 250 Oz-In Max.
Moment of Inertia Per Deck	21 lb. In. ²
Mechanical Life	
All units are designed to meet a minimum mechanical life of 250,000 cycles while operating at rated voltage and current, and without brush replacement.	

Environmental

Operating Temperature

Enclosed or Screened Units:

Average ambient temperature for any 24 hour period not to exceed 30°C, and the maximum temperature not to exceed 40°C.

Open Construction Units:

Average ambient temperature for any 24 hour period not to exceed 40°C, and the maximum temperature not to exceed 50°C

When operation is required in maximum ambient temperatures higher than 40°C for enclosed units or 50°C for open construction units, the output current must be reduced as follows. See page 3 for temperature curve.

Maximum Ambient	50°C	60°C	70°C
Open Units (% Rated Load)	100%	90%	75%
Enclosed Units (Rated Load)	90%	75%	52%

Minimum Operating Temperature -20°C

Storage Temperature: -40° to +70°C

Humidity, Operating and Storage:

7 day average relative humidity 20 to 75%
Maximum (non-condensing) 95%

Altitude

Operating: 6,600 ft (2,000 meters) max - no derating
When operation is required at higher altitudes, the load current and maximum ambient temperature must be derated as follows:

MAXIMUM ALTITUDE	DERATING
10,000 ft. (3,000 meters)	Load to 95% Max. Ambient 30°C
15,000 ft. (4,500 meters)	Load to 90% Max. Ambient 20°C

Storage: 50,000 ft (15,000 meters) max.

Weights

MANUAL UNITS

Decks	Open, Screened & Terminal Enclosure Construction				POWERSTAT Unit In NEMA I Enclosure (N01 Suffix)				
	Net Lbs Kg		Shipping Lbs Kg		Enclosure Type No.	Net Lbs Kg		Shipping Lbs Kg	
1	82	37	92	42	PBA50-N01-A	180	83	230	110
2	170	77	190	86	PBA50-N01-B	300	140	350	160
3	250	110	280	130	PBA50-N01-C	410	190	460	210
4	370	170	420	190	PBA50-N01-D	540	240	590	270
5	460	210	510	230	PBA50-N01-D	620	280	670	310
6	550	250	600	270	PBA50-N01-E	740	340	790	360
7	630	290	680	310					
8	720	330	770	350					
9	800	360	850	390					

MOTORIZED UNITS

Decks/ Connection	Open, Screened & Terminal Enclosure Construction				POWERSTAT Unit In NEMA I Enclosure (N01 Suffix)				
	Net Lbs Kg		Shipping Lbs Kg		Enclosure Type No.	Net Lbs Kg		Shipping Lbs Kg	
1	100	45	110	50	PBA50-N01-B	230	100	280	130
2	190	86	210	95	PBA50-N01-C	350	160	400	180
3	270	120	300	140	PBA50-N01-D	460	210	510	230
4	390	180	440	200	PBA50-N01-D	560	250	610	280
5	480	220	530	240	PBA50-N01-E	670	300	720	330
6	570	260	620	280	PBA50-N01-E	760	350	810	370
7	650	300	700	320	PBA50-N01-F	900	410	950	430
8	740	340	790	360	PBA50-N01-F	980	450	1,030	470
9	820	370	870	400	PBA50-N01-F	1,070	490	1,120	510
10	960	440	1,060	480	PBA50-N01-EE	1,450	660	1,550	700
12 D & PS	1,150	520	1,250	570	PBA50-N01-EE	1,650	750	1,750	790
12 Y	1,200	540	1,300	590	PBA50-N01-DD	1,600	730	1,700	770
14	1,300	590	1,400	640	PBA50-N01-FF	1,900	860	2,000	910
15	1,450	660	1,550	700	PBA50-N01-EE	1,900	860	2,000	910
16	1,500	680	1,600	730	PBA50-N01-FF	2,100	950	2,200	1,000
18 D & PS	1,650	750	1,750	800	PBA50-N01-GG	2,300	1,050	2,400	1,100
18 Y	1,700	770	1,800	820	PBA50-N01-EE	2,150	980	2,250	1,000
21	1,950	890	2,050	930	PBA50-N01-FF	2,500	1,150	2,600	1,200
24	2,200	1,000	2,300	1,050	PBA50-N01-FF	2,750	1,250	2,850	1,300
27	2,450	1,100	2,550	1,150	PBA50-N01-GG	3,100	1,400	3,200	1,450

Outline Dimensions Single Assembly Manually Operated and Motor-Driven

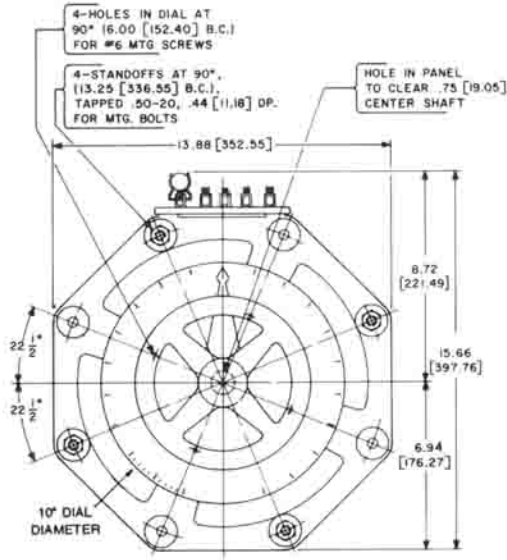
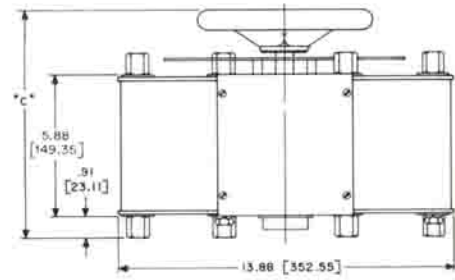
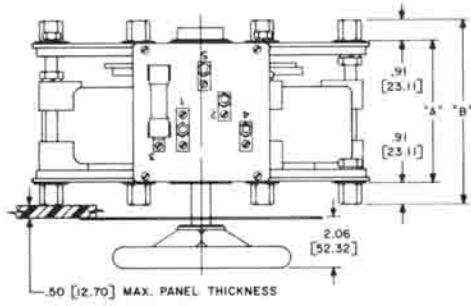

Panel Mounted

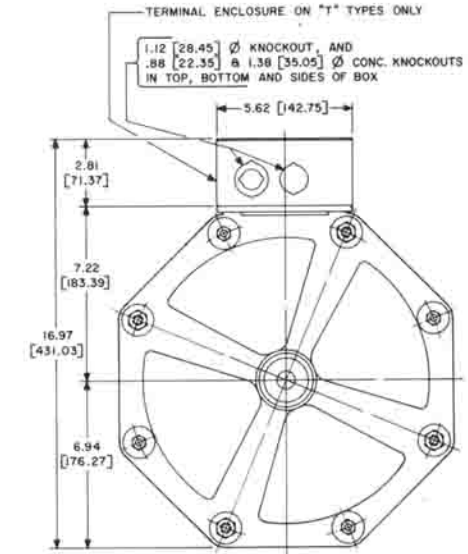

Bench or Wall Mounted

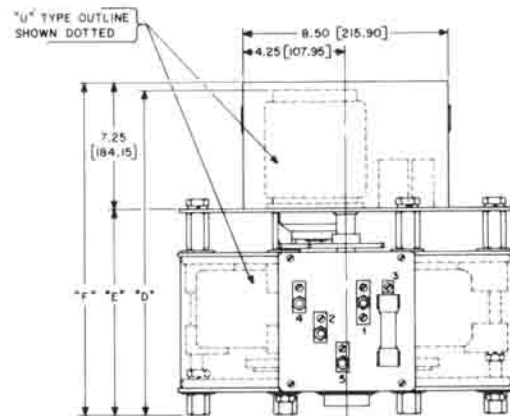
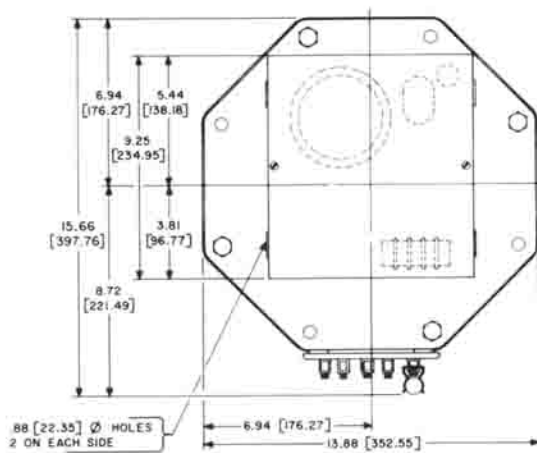

Motor-Driven

All dimensions are in inches (millimeters).

Type	"A"	"B"	"C"	"D"	"E"	"F"
Single	5.88 [149.35]	7.69 [195.32]	9.47 [240.54]	15.44 [392.18]	8.50 [215.90]	15.76 [400.30]

Outline Dimensions 2-Deck and 3-Deck Manually Operated and Motor-Driven Types

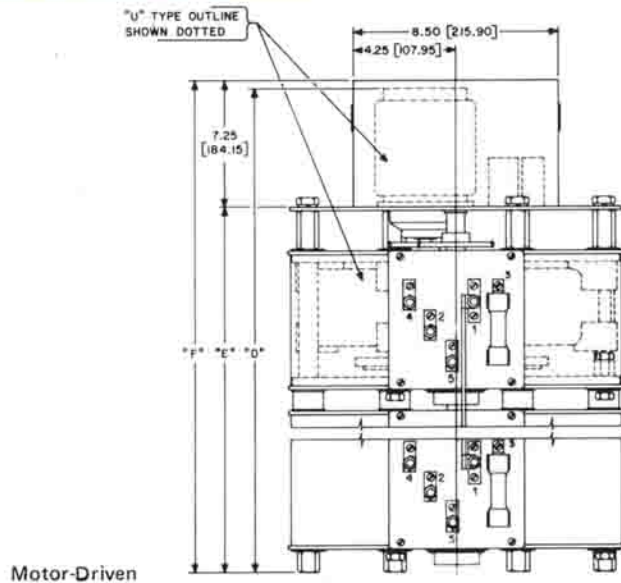
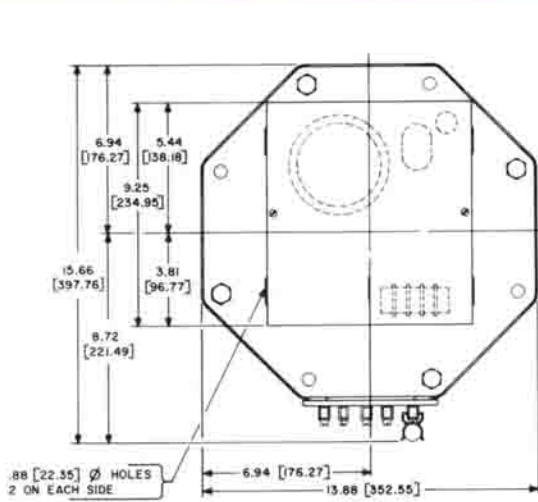
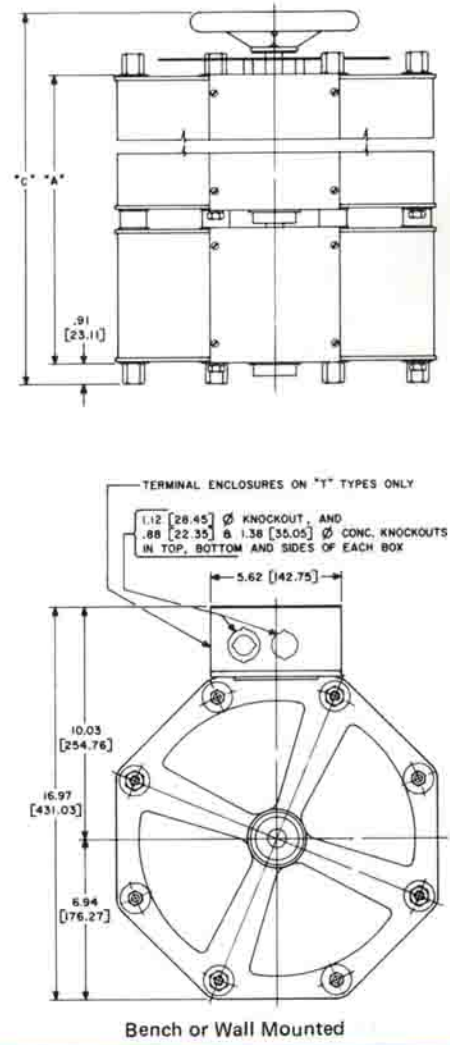
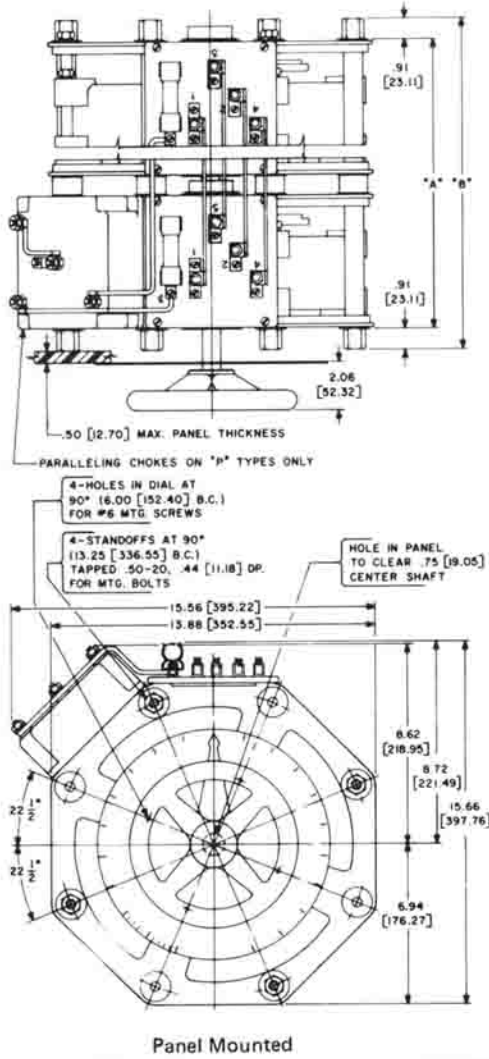

All dimensions are in inches (millimeters).

Type	"A"	"B"	"C"	"D"	"E"	"F"
2-Deck	12.50 [317.50]	14.31 [363.47]	16.09 [408.69]	22.06 [560.32]	15.12 [384.05]	22.38 [568.45]
3-Deck	19.12 [485.65]	20.94 [531.87]	22.72 [577.09]	28.69 [728.73]	21.75 [552.45]	29.00 [736.60]

Outline Dimensions 4-Deck to 9-Deck Manually Operated and Motor-Driven Types

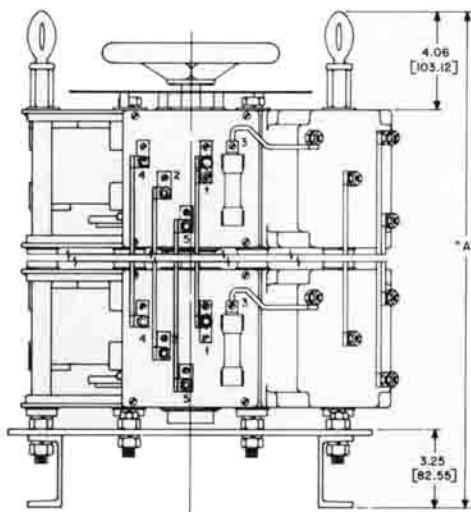
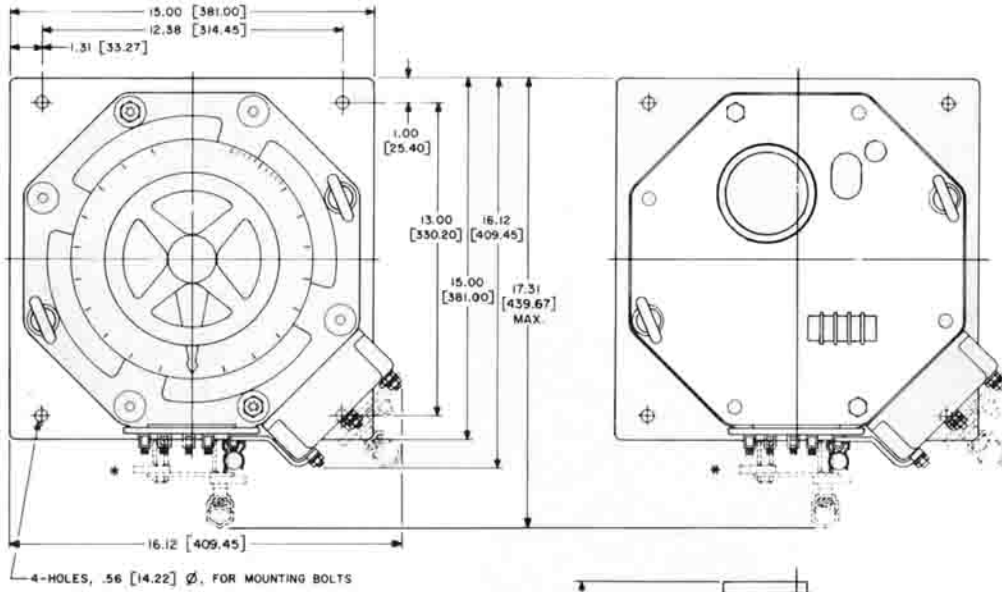

4- to 9-Deck Manual

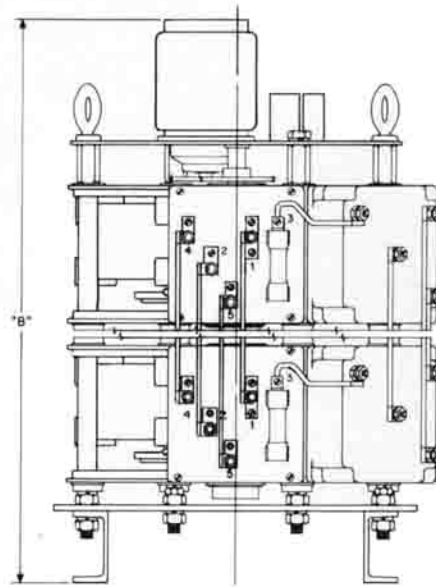

4- to 9-Deck Motor-Driven

* Interconnections are by bus bars for Types 4P, 5P, 6P, 7P, 8D, 8PS, 8P and 9P as illustrated.

Type	"A"	"B"
4D, 4PS	34.00 [863.60]	38.56 [979.42]
4P	34.00 [863.60]	38.56 [979.42]
5P	40.62 [1031.75]	45.19 [1147.83]
6D, 6PS 6Y	47.25 [1200.15]	51.82 [1316.23]
6P	47.25 [1200.15]	51.82 [1316.23]
7P	53.88 [1368.55]	58.44 [1484.38]
8D, 8PS	60.50 [1536.70]	65.07 [1652.78]
8P	60.50 [1536.70]	65.07 [1652.78]
9P	67.12 [1704.85]	71.69 [1820.93]
9Y	67.12 [1704.85]	71.69 [1820.93]

All dimensions are in inches (millimeters).

Outline Dimensions 10-Deck to 27-Deck Motor-Driven Types

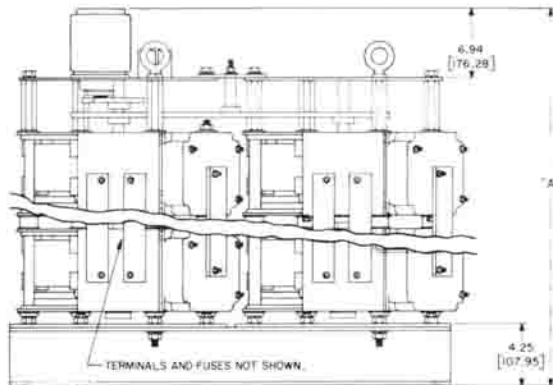
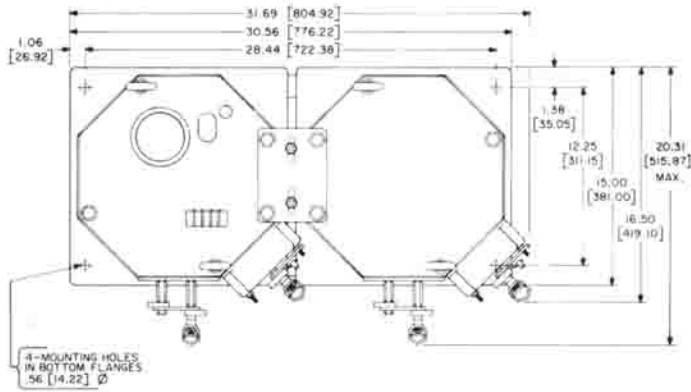

Type	"A"
10D, 10PS	49.44 (1255.78)
12D, 12PS	56.06 (1423.92)
14D, 14PS	62.69 (1592.33)
16D, 16PS	69.31 (1760.47)
18D, 18PS	75.94 (1928.88)

10- to 18-Deck Open Delta and Series-Parallel Types

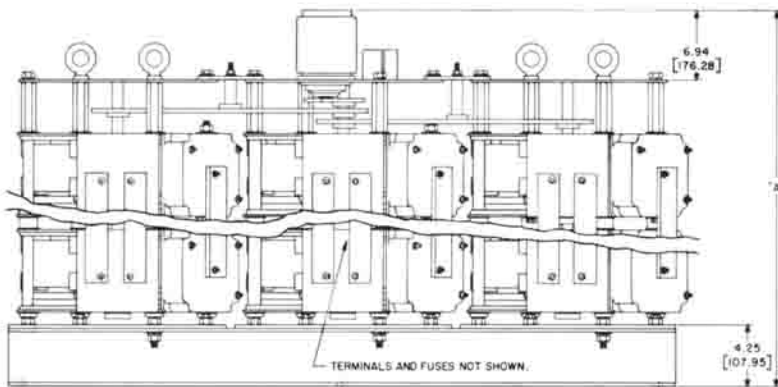
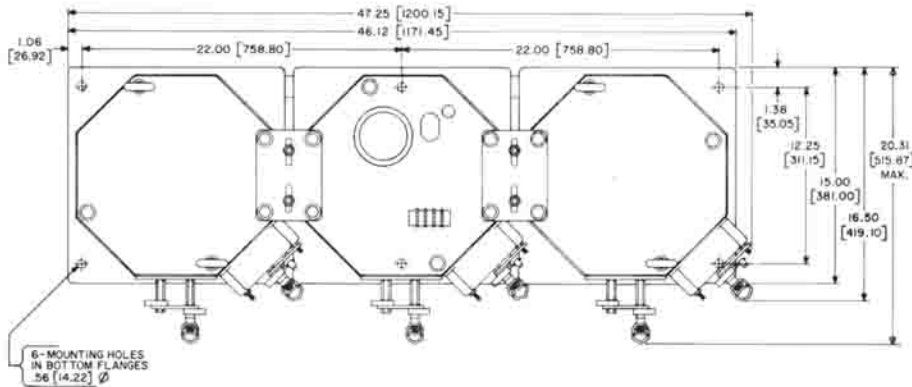

Type	"A"
12Y	42.82 (1087.63)
15Y	49.44 (1255.78)
18Y	56.06 (1423.92)
21Y	62.69 (1592.33)
24Y	69.31 (1760.47)
27Y	75.94 (1928.88)

12- to 27-Deck Wye Types

All dimensions are in inches (millimeters).

PBA50 Series Outline Dimensions

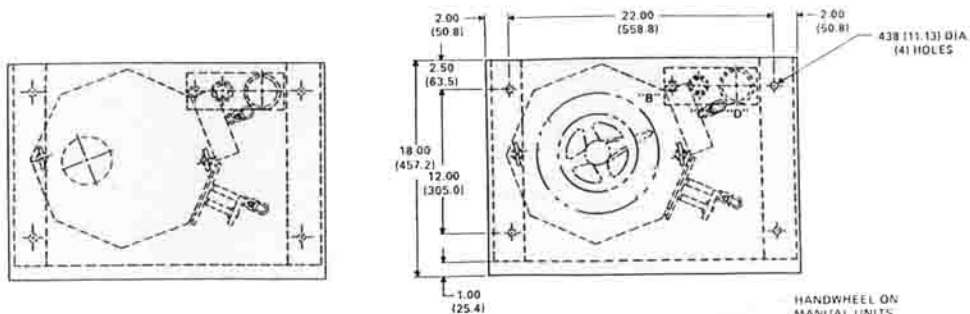

Type	Dimension "A"
PBA50-N01-A	16.25 (412.75)
PBA50-N01-B	24.25 (615.95)
PBA50-N01-C	34.25 (869.95)
PBA50-N01-D	46.25 (1174.75)
PBA50-N01-E	56.25 (1428.75)
PBA50-N01-F *	74.25 (1885.95)

* Motorized units only.

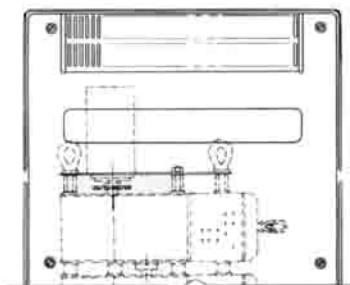

Motor Driven

Concentric Knockouts

Designation	Diameter: Inches (Millimeters)
"B"	.88 (22.3) & 1.12 (28.5)
"C"	1.38 (35.0), 1.75 (44.5) & 2.00 (50.8)
"D"	2.50 (63.5) & 3.00 (76.2)

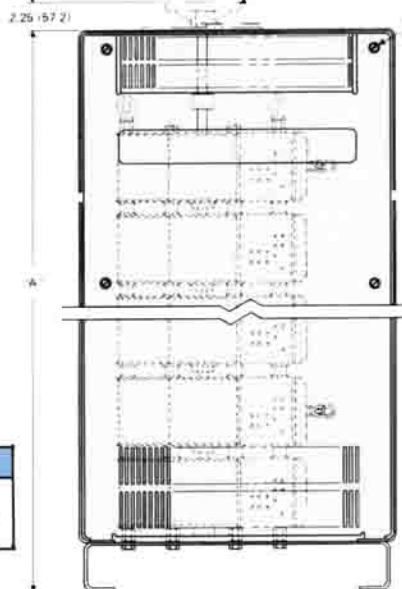

Manually Operated

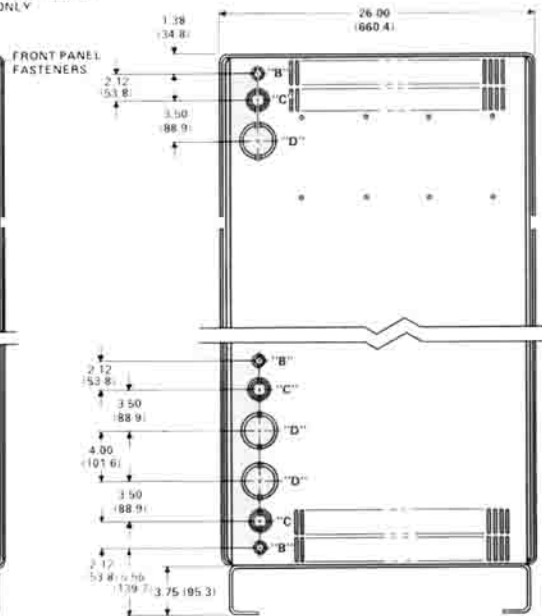

*NOTE: These enclosures are only available as factory installed options for motor driven POWERSTAT Variable Transformers.

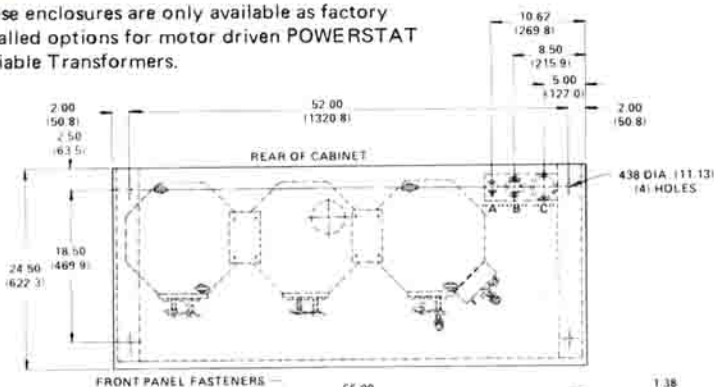

Type	Dimension "A"
PBA50-N01-DD *	46.25 (1174.75)
PBA50-N01-EE *	56.25 (1428.75)
PBA50-N01-FF *	74.25 (1885.95)
PBA50-N01-GG *	88.25 (2241.55)

Concentric Knockouts

Designation	Diameter: Inches (Millimeters)
"A"	.88 (22.3) & 1.12 (28.5)
"B"	1.38 (35.0), 1.75 (44.5) & 2.00 (50.8)
"C"	2.50 (63.5) & 3.00 (76.2)

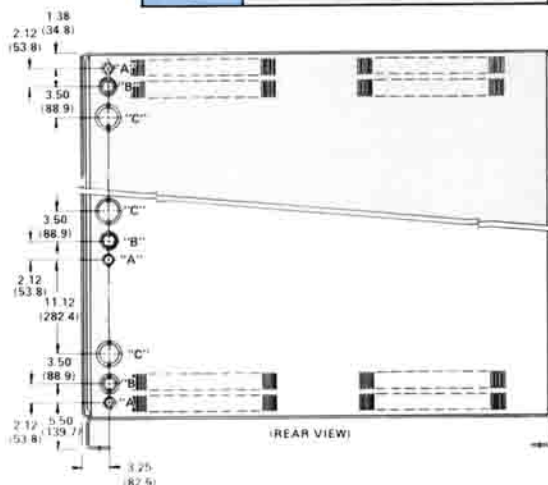
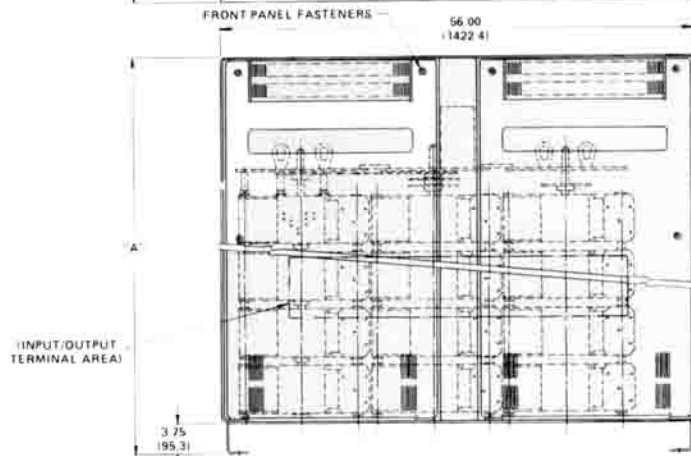

POWERSTAT® Positioner Controller Type PD120B

With Positioner Control PD120B, a synchronous motor driven POWERSTAT Variable Transformer is automatically driven to a setting proportional to the position of a control potentiometer. For example, if the control potentiometer is set at the mid position, the output voltage of the POWERSTAT unit will be driven to 50 percent of the full output voltage. The positioner controller does not regulate the output voltage. Changes in the input voltage will be reflected in the output voltage. Any number of motor-driven POWERSTAT units can be controlled from a compact control station.

A complete positioner system consists of a positioner controller type PD120B, a user supplied 1000 ohm, 3 W control potentiometer and a synchronous motor driven POWERSTAT Variable Transformer. The potentiometer can be mounted at the most suitable control location. Potentiometer kit 026602-008 consisting of a knob, a dial and a potentiometer is available for use with positioner systems.

The wiring diagram for a complete positioner system is shown in Figure A. When used with a 240 or 480 V POWERSTAT Variable Transformer, a type T6068 step-down transformer is required in the output voltage sensing leads. Although two POWERSTAT units can be controlled from one potentiometer, one positioner controller is required for each POWERSTAT assembly. Figure B shows



Positioner Control Type PD120B

how two or more positioner controlled units can be mastered using a POWERSTAT Variable Transformer Type 10C to vary the input to the control potentiometers.

Consult the factory Application Support Group if the positioner system is to be used with other than a 120 V, 50/60 Hz synchronous motor drive or if the control is to be used on a 600 V system.

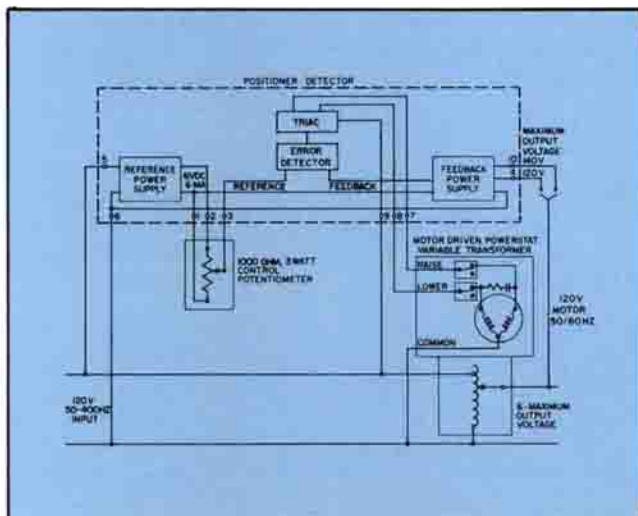

Figure A

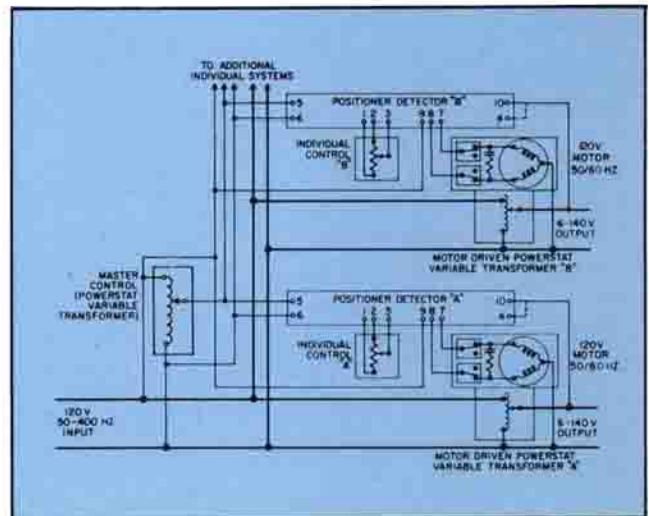

Figure B

All dimensions are in inches (millimeters).

STABILINE® Full Range Regulator Controllers

...for use with any synchronous motor driven
POWERSTAT Variable Transformer to provide:

- **Regulated AC voltage**
- **Regulated AC current**
- **Regulated DC voltage**



A STABILINE Full Range Regulator Controller is a solid-state device which monitors the load voltage or current of a motor-driven POWERSTAT Variable Transformer and operates the motor drive to hold the output constant at the selected value. Any load voltage or current value within the full range of the POWERSTAT unit can be selected. These controllers are ideal for applications requiring a wide range of regulated current or voltage or where wide input voltage variations will be encountered.

Types prefixed FR are for use with 120 V POWERSTAT assembly motor drives; types prefixed FRX are for use with 240 V motor drives.

Types FR501B and FRX501B are AC controllers for use where the output is to be remotely selected from a separate user supplied output adjustment potentiometer (1 K ohm, 3 W) or a 0 to 6 V, 6 mA reference source. Potentiometer Kit 026602-008 consisting of a knob, dial and potentiometer is offered for use with these units.

Types FR501BMP and FRX501BMP are AC controllers which have the output adjust potentiometer and an output voltmeter furnished as part of the unit.

Types FR501BDC and FRX501BDC are DC voltage controllers. A separate output adjustment potentiometer (1 K ohm, 3 W) or a 0 to 6 V, 6 mA reference source is required to set the desired output voltage. Potentiometer Kit 026602-008 consisting of a knob, dial and potentiometer is offered for this purpose.

Regulated AC Voltage

All AC versions of STABILINE Full Range Regulator Controllers can be used to provide regulated AC voltage when used with synchronous motor driven POWERSTAT Variable Transformers. This combination will maintain a constant output voltage accurate within ± 0.8 percent of the maximum output voltage. All AC controllers can be connected to provide a maximum output voltage of 120, 140, 240, 280, 480, or 600 V at 50/60/400 Hz. For 480 or 600 V applications, a 4:1 step-down transformer Type T6026 is required.

Regulated AC Current

With the addition of a T6340 transformer, the FR501B and FRX501B STABILINE Full Range Regulator Controllers can be used with synchronous motor driven

POWERSTAT Variable Transformers to automatically regulate current.

When used with these STABILINE Full Range Regulator Controllers, the T6340 sense transformer converts AC 0 to 5 A into voltage which is sensed by the controller to direct the POWERSTAT unit in regulating the load current.

To regulate load currents greater than 5 A, a separate current transformer is needed to convert the load current to the 0 to 5 A required by the T6340 sense transformer. Most current transformers deliver 0 to 5 A when the current through the transformer is varied between 0 and the rated current of the transformer. The current transformer must be rated to supply 0 to 5 A, 10 VA minimum to the T6340 sense transformer.

Warner Electric offers two current transformers suitable for load currents up to 500 A. The 300:5 A current transformer (Part No. 220282-001) is used for several current ranges depending on the number of times the load wire is passed through the current transformer.

Maximum Load Current	Number of times load wire passes through 300:5 current transformer.
50	6
75	4
150	2
300	1

The 500:5 A current transformer (Part No. 220282-002) is used for currents up to 500 A.

The combination will maintain constant output current accurate within ± 1 percent of the rated load current. Load current can be regulated from 0 to maximum.

Regulated DC Voltage

STABILINE Full Range Regulator Controllers with DC suffixes provide regulated DC voltage when used with a synchronous motor driven POWERSTAT Variable Transformer that is powering a user supplied rectifier assembly. Types FR501BDC and FRX501BDC both require 0 to 28 VDC and 16 mA to the sensing terminals. This combination will maintain constant DC voltage accurate within ± 0.8 percent of the maximum DC voltage output.

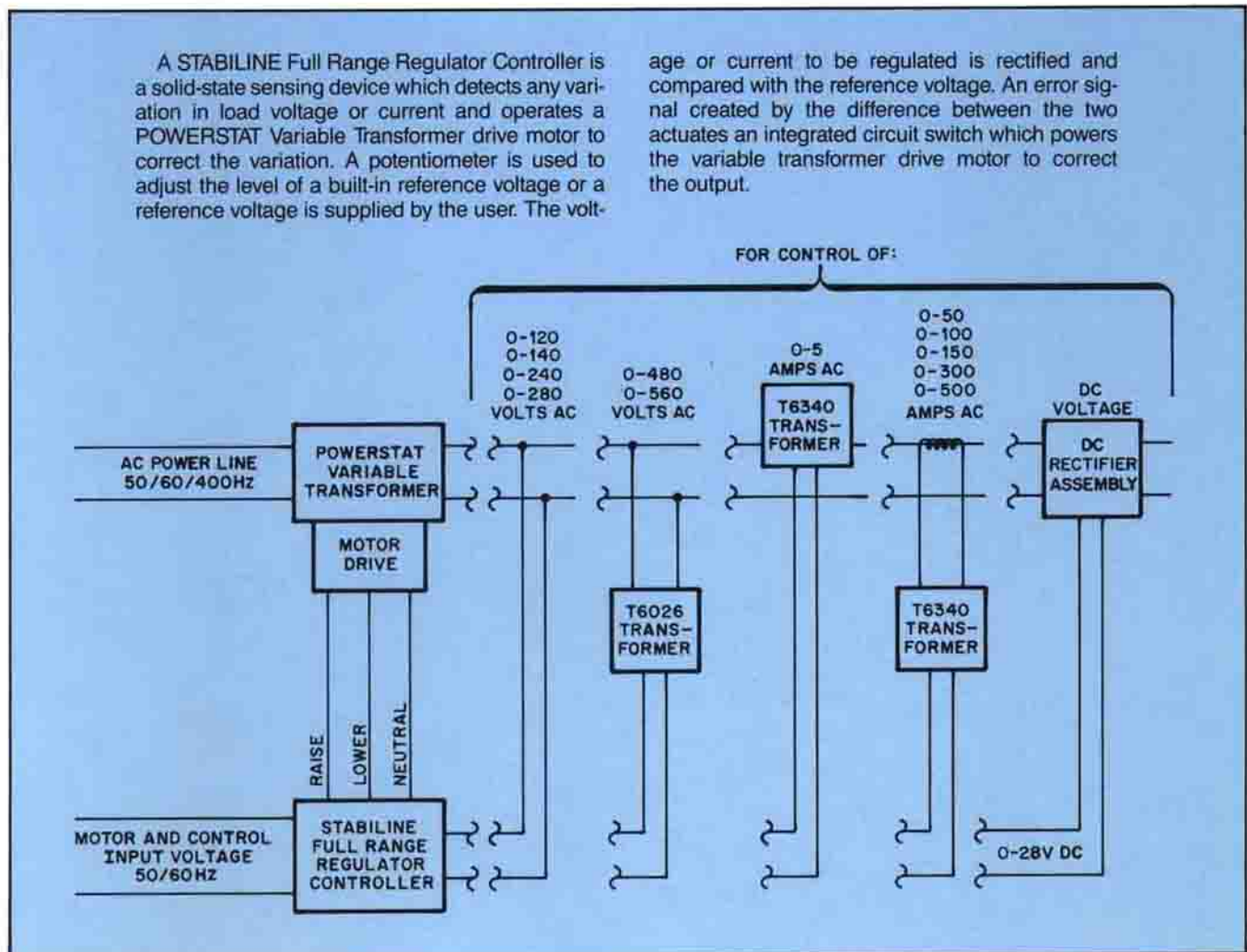

System Requirements

Regulated Output	Motor & Control Voltage	Control Type	Load Volt/Amp Range	Required Sensing Components	
				Part No.	Description
AC VOLTAGE	120 Nom. (95 – 135)	FR501B* FR501BMP	0-120, 0-140 0-240, 0-280		None Required
	240 Nom. (216 – 264)	FRX501B* FRX501BMP	0-480, 0-600**	T6026	Step-Down Transformer
AC CURRENT	120 Nom. (95 – 135)	FR501B*	0-5	T6340	5 A Sense Transformer
			0-50, 0-100 0-150, 0-300	T6340 And 220282-001	5 A Sense Transformer 300:5 Current Transformer
	240 Nom. (216 – 264)	FRX501B*	0-500	T6340 220282-002	5 A Sense Transformer 500:5 Current Transformer
			0-Above 500	T6340 And Current Transformer	5 A Sense Transformer User Supplied
DC VOLTAGE	120 Nom. (95-135)	FR501BDC*	0-28		None Required
	240 Nom. (216 – 264)	FRX501BDC*			

* Potentiometer Kit 026602-008 or equivalent also required.

** Not recommended for BMP models.

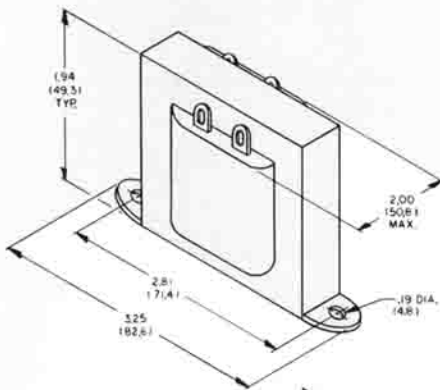

T6026 & T6340 Transformers

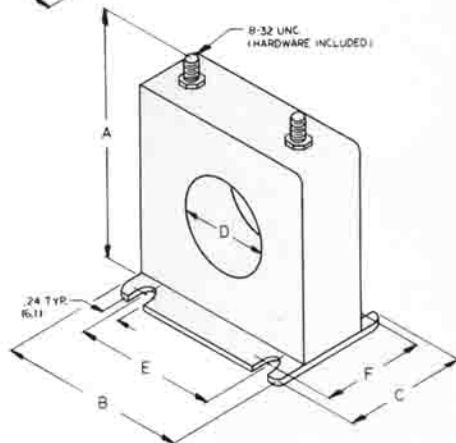

Current Transformers

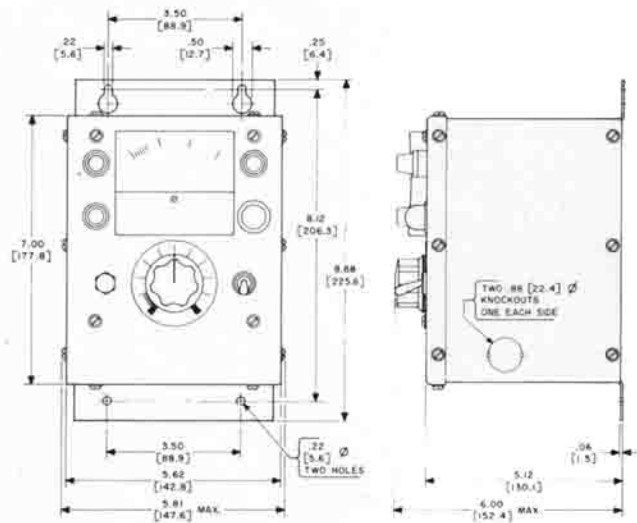

Types FR501BMP & FRX501BMP

Current Transformer	Dimensions					
	A	B	C	D	E	F
220282-001 300:5	3.11 (79.0)	2.33 (59.2)	1.88 (47.8)	1.13 (28.7)	1.70 (43.2)	1.60 (40.6)
220282-002 500:5	4.07 (103.4)	3.50 (88.9)	2.15 (54.6)	1.56 (39.6)	2.70 (68.6)	1.79 (45.5)

All dimensions are in inches (millimeters).

Distribution Coast-to-Coast and International

Superior Electric products are available worldwide through an extensive authorized distributor network. These distributors offer literature, technical assistance and a wide range of models off the shelf for fastest possible delivery and service.

In addition, Superior Electric sales representatives are available to provide prompt attention to customer needs. Call or fax for ordering and application information or for the name and address of the nearest authorized distributor.

383 Middle Street
Bristol, CT 06010 USA
Tel: 860-585-4500
Fax: 860-582-3784
Web: www.superiorelectric.com

Toll Free in USA and Canada

Customer Service: 1-800-787-3532 - Ext. 4750
Product Application: 1-800-787-3532 - Ext. 4755
Product Literature Requests: 1-800-787-3532 - Ext. 4750
Fax: 1-800-821-1369

Superior
Electric

383 Middle Street • Bristol, CT 06010 USA
Tel: 860.585.4500 • Fax: 860.584.1483

