

**LOW COST MICROPROFILE SMD
LINE MATCHING TRANSFORMER****P3191****Features**

- * Low Cost
- * Surface Mount
- * 7mm seated height
- * Vacuum encapsulated
- * IEC 950, UL 1950 and EN 60950 certified
- * UL Recognized Component
- * BAPT Certificate of Recognition
- * CSA NRTL/C Certificate of Conformity
- * Simple 600Ω match

Applications

- * Telecommunications
- * V.34 modems
- * Portable computers
- * Fax/Modems

DESCRIPTION

P3191 is a low distortion microprofile transformer for applications where high performance and safety isolation to international standards are required in an extremely small case size.

Designed specifically as a surface mount device, the P3191 features a 7mm seated height and is offered in the same package as the now familiar P2781.

Despite the subminiature size, the performance is superior to that of much larger components. The P3191 offers reinforced insulation, is ideal for data communications at high data rates whilst capable of being matched to both 600Ω and complex impedance telephone lines.

When used with 600Ω lines no external compensation components are required.

At moderate transmit power levels (e.g. -10dBm) performance to 33,600 bits/second may be achieved.

P3191 is certified to IEC 950, EN 60950, EN 41003 and UL1950. P3191 is a UL Recognized Component, and is supported by a BAPT Certificate of Recognition, a CSA Certificate of Conformity and an IEC CB Test Certificate.



to Electronic Techniques
(Anglia) Limited

SPECIFICATIONS

Electrical

At T = 25°C and as circuit Fig. 2 unless otherwise stated.

Parameter	Conditions	Min	Typ	Max	Units
Insertion Loss	f = 2kHz	-	-	4.5	dB
Frequency response	-3dB LF cutoff	-	50	-	Hz
	-3dB HF cutoff	-	35	-	kHz
	200Hz - 4kHz	-	-	±0.2	dB
Return Loss	200Hz - 4kHz	16	-	-	dB
Third Harmonic Distortion ⁽¹⁾	600Hz -10dBm in line	-	-93	-	dBm
Balance	DC - 5kHz Method TG25	80	-	-	dB
Saturation	Excitation 50Hz 250Vrms. Output voltage across line	-	-	10	Vrms
		-	-	65	Vpeak
Voltage isolation ⁽²⁾	50Hz	3.88	-	-	kVrms
	DC	5.5	-	-	kV
Operating range: Functional Storage ⁽⁵⁾	Ambient temperature	-10	-	+85	°C
		-40	-	+125	°C

Lumped equivalent circuit parameters as Fig. 1

DC resistance, R _{DC} ⁽³⁾	Sum of windings	270	-	340	Ω
Leakage inductance ΔL		-	5.6	-	mH
Shunt inductance L _p ⁽⁴⁾	-43dBm 200Hz	2.4	-	-	H
Shunt loss R _p ⁽⁴⁾	-43dBm 200Hz	7	-	-	kΩ

Notes

- Third harmonic typically exceeds other harmonics by 20dB.
- Components are 100% tested at 6.5 kVDC.
- Caution: do not pass DC through windings. Telephone line current, etc. must be diverted using choke or semiconductor line hold circuit.
- At signal levels greater than -20dBm, L_p will increase and R_p will decrease slightly but the effect is usually favourable to the return loss characteristic.
- Excludes shipping materials. Components are dry-packed and sealed as shipped. Refer to Profec Technologies for appropriate storage conditions for sealed consignments.

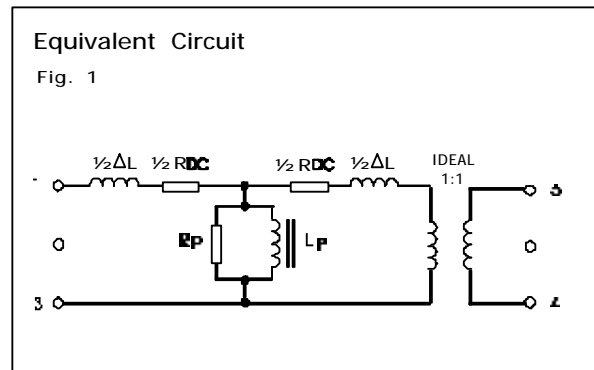

MATCHING RECOMMENDATIONS

600Ω MATCH

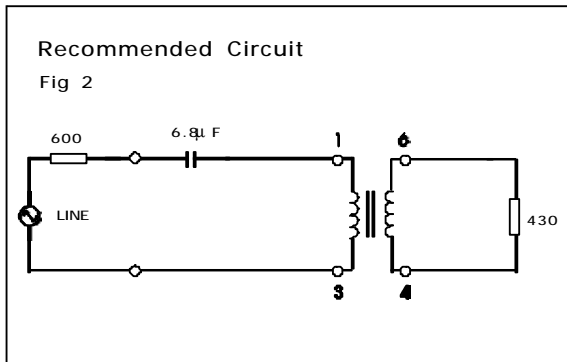

EUROPEAN CTR21 COMPLEX MATCH

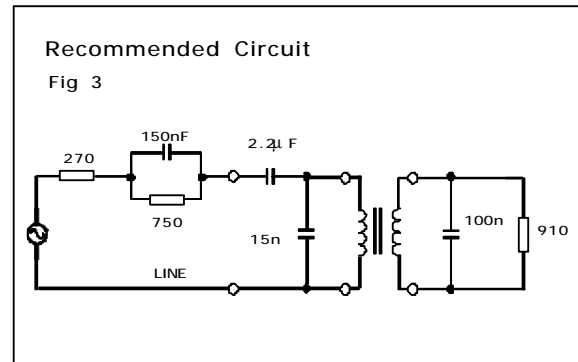

In practice, the 910Ω load resistor will connect to a low output impedance TX driver. The 100nF capacitor should appear in parallel with the 910Ω load resistor (rather than in parallel with transformer winding) to obtain optimum TX flatness to line.

CONSTRUCTION

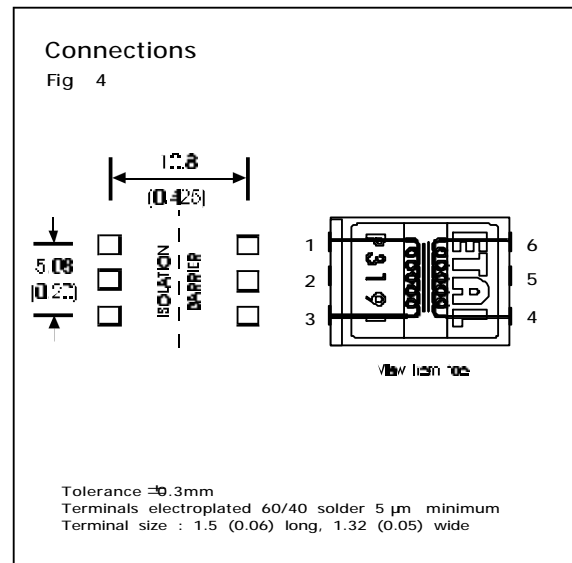
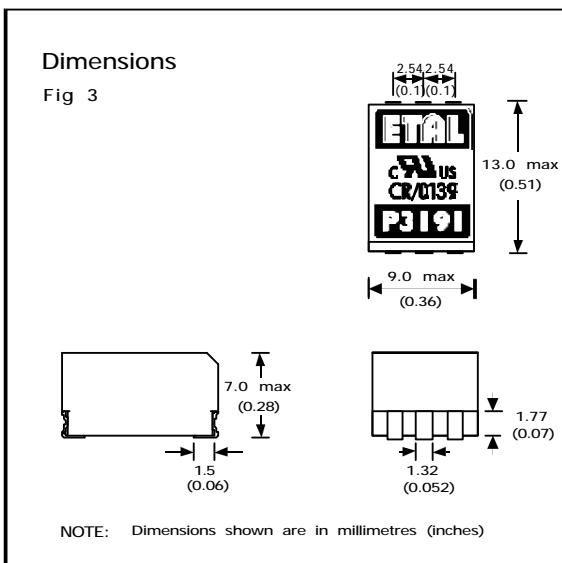

Dimensions shown are in millimetres (inches).
Geometric centres of outline and pad grid coincide within a tolerance circle of 0.3mm \varnothing .
Windings may be used interchangeably as primary or secondary.

SAFETY

Manufactured from materials conforming to flammability requirements of UL94V-0 and EN 60950:1992 (BS 7002:1992) sub-clause 1.2.13.2 (V-0).

Distance through reinforced insulation 0.4mm minimum.

Creepage and clearances in circuit are 7mm minimum where PCB pads do not exceed 3mmØ. Constructed and fully encapsulated in accordance EN 60950:1992 (BS 7002:1992) and BS EN 41003:1997 (reinforced), 250Vrms maximum working voltage.

CERTIFICATION

Certified by BSI to IEC 950:1991/A4:1996 (IEC CB Test Certificate No. GB441W) sub-clauses 1.5, 1.5.1, 1.5.3, 2.2, 2.2.2, 2.2.3, 2.2.4, 2.9.2, 2.9.3, 2.9.4, 2.9.6, 2.9.7, 4.4, 4.4.3.2 (class V-0) and 5.3 for a maximum working voltage of 250Vrms, nominal mains supply voltage not exceeding 250Vrms and a maximum operating temperature of +85°C in Pollution Degree 2 environment, reinforced insulation.

CAN/CSA C22.2 No. 950-95/UL1950, certified by CSA, Third Edition, including revisions through to revision date March 1, 1998, based on Fourth Amendment of IEC 950, Second Edition, maximum working voltage 250Vrms, Pollution Degree 2, reinforced insulation.

UL File number E203175.

CSA Certificate of Compliance 1107696 (Master Contract 1188107).

Certified by BABT to EN 60950.

BABT Certificate CR/0139.

Additionally, Profec Technologies certifies all transformers as providing voltage isolation of 3.88kVrms, 5.5kV DC minimum. All shipments are supported by a Certificate of Conformity to current applicable safety standards.

ABSOLUTE MAXIMUM RATINGS

(Ratings of components independent of circuit).

Short term isolation voltage (2s)	4.6kVrms, 6.5kVDC
DC current	100µA
Storage temperature	-40°C to +125°C
Soldering temperature	
Profile peak - either	240°C 60s
or	250°C 30s
or	260°C 10s

COPYRIGHT

ETAL, P3191 and P2781 are Trade Marks of Profec Technologies Ltd.

The Trade Mark ETAL is registered at the UK Trade Marks Registry.

Profec Technologies Ltd. is the owner of the design right under the Copyright Designs and Patents Act 1988 and no rights or licences are hereby granted or implied to any third party.

© 1998 and 2000 Profec Technologies Ltd.

Reproduction prohibited.

PROFEC
TRANSFORMING THE FUTURE



ISO 9001
FM 25326

Profec Technologies Ltd., 10 Betts Avenue, Martlesham Heath, Ipswich, IP5 3RH, England

Telephone: +44 (0) 1473 611422

Fax: +44 (0) 1473 611919

Websites: www.etal.ltd.uk

www.profec.com

Email: info@etal.ltd.uk

sales@profec.com