

DATA SHEET

EFD12/6/3.5 EFD cores and accessories

Supersedes data of February 2002

2004 Sep 01

CORES

Effective core parameters

SYMBOL	PARAMETER	VALUE	UNIT
$\Sigma(l/A)$	core factor (C1)	2.50	mm ⁻¹
V_e	effective volume	325	mm ³
l_e	effective length	28.5	mm
A_e	effective area	11.4	mm ²
A_{min}	minimum area	10.7	mm ²
m	mass of core half	≈ 0.9	g

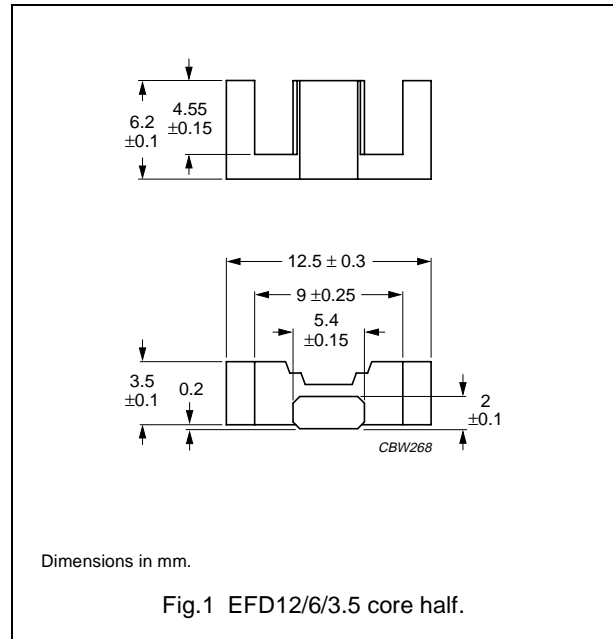

Core sets

Clamping force for A_L measurements, 15 ± 5 N.

GRADE	A_L (nH)	μ_e	AIR GAP (μ m)	TYPE NUMBER
3C90	40 ± 5%	≈ 80	≈ 540	EFD12/6/3.5-3C90-A40-S
	63 ± 8%	≈ 125	≈ 290	EFD12/6/3.5-3C90-A63-S
	100 ± 10%	≈ 200	≈ 160	EFD12/6/3.5-3C90-A100-S
	825 ± 25%	≈ 1610	≈ 0	EFD12/6/3.5-3C90-S
3C94	40 ± 5%	≈ 80	≈ 540	EFD12/6/3.5-3C94-A40-S
	63 ± 8%	≈ 125	≈ 290	EFD12/6/3.5-3C94-A63-S
	100 ± 10%	≈ 200	≈ 160	EFD12/6/3.5-3C94-A100-S
	825 ± 25%	≈ 1610	≈ 0	EFD12/6/3.5-3C94-S
3C96 <small>des</small>	750 ± 25%	≈ 1460	≈ 0	EFD12/6/3.5-3C96-S
3F3	40 ± 5%	≈ 80	≈ 540	EFD12/6/3.5-3F3-A40-S
	63 ± 8%	≈ 125	≈ 290	EFD12/6/3.5-3F3-A63-S
	100 ± 10%	≈ 200	≈ 160	EFD12/6/3.5-3F3-A100-S
	700 ± 25%	≈ 1370	≈ 0	EFD12/6/3.5-3F3-S
3F35 <small>prot</small>	550 ± 25%	≈ 1070	≈ 0	EFD12/6/3.5-3F35-S
3F4 <small>des</small>	40 ± 5%	≈ 80	≈ 500	EFD12/6/3.5-3F4-A40-S
	63 ± 8%	≈ 125	≈ 260	EFD12/6/3.5-3F4-A63-S
	100 ± 10%	≈ 200	≈ 130	EFD12/6/3.5-3F4-A100-S
	380 ± 25%	≈ 730	≈ 0	EFD12/6/3.5-3F4-S
3F45 <small>prot</small>	380 ± 25%	≈ 730	≈ 0	EFD12/6/3.5-3F45-S

Properties of core sets under power conditions

GRADE	B (mT) at	CORE LOSS (W) at			
	H = 250 A/m; f = 25 kHz; T = 100 °C	f = 100 kHz; B̂ = 100 mT; T = 100 °C	f = 100 kHz; B̂ = 200 mT; T = 100 °C	f = 400 kHz; B̂ = 50 mT; T = 100 °C	f = 500 kHz; B̂ = 50 mT; T = 100 °C
3C90	≥320	≤ 0.036	–	–	–
3C94	≥320	≤ 0.029	≤ 0.2	–	–
3C96	≥340	≤ 0.022	≤ 0.15	≤ 0.06	≤ 0.12
3F35	≥300	–	–	≤ 0.03	≤ 0.045
3F3	≥315	≤ 0.04	–	≤ 0.065	–
3F4	≥250	–	–	–	–

Properties of core sets under power conditions (continued)

GRADE	B (mT) at	CORE LOSS (W) at			
	H = 250 A/m; f = 25 kHz; T = 100 °C	f = 500 kHz; B̂ = 100 mT; T = 100 °C	f = 1 MHz; B̂ = 30 mT; T = 100 °C	f = 1 MHz; B̂ = 50 mT; T = 100 °C	f = 3 MHz; B̂ = 10 mT; T = 100 °C
3C90	≥320	–	–	–	–
3C94	≥320	–	–	–	–
3C96	≥340	–	–	–	–
3F35	≥300	≤ 0.35	–	–	–
3F3	≥315	–	–	–	–
3F4	≥250	–	≤ 0.09	–	≤ 0.15
3F45	≥250	–	≤ 0.065	≤ 0.16	≤ 0.11

COIL FORMERS

General data

ITEM	SPECIFICATION
Coil former material	liquid crystal polymer (LCP), glass reinforced, flame retardant in accordance with "UL 94V-0"; UL file number E83005(M)
Solder pad material	copper-tin alloy (CuSn), tin (Sn) plated
Maximum operating temperature	155 °C, "IEC 60085", class F
Resistance to soldering heat	"IEC 60068-2-20", Part 2, Test Tb, method 1B, 350 °C, 3.5 s
Solderability	"IEC 60068-2-20", Part 2, Test Ta, method 1: 235 °C, 2 s

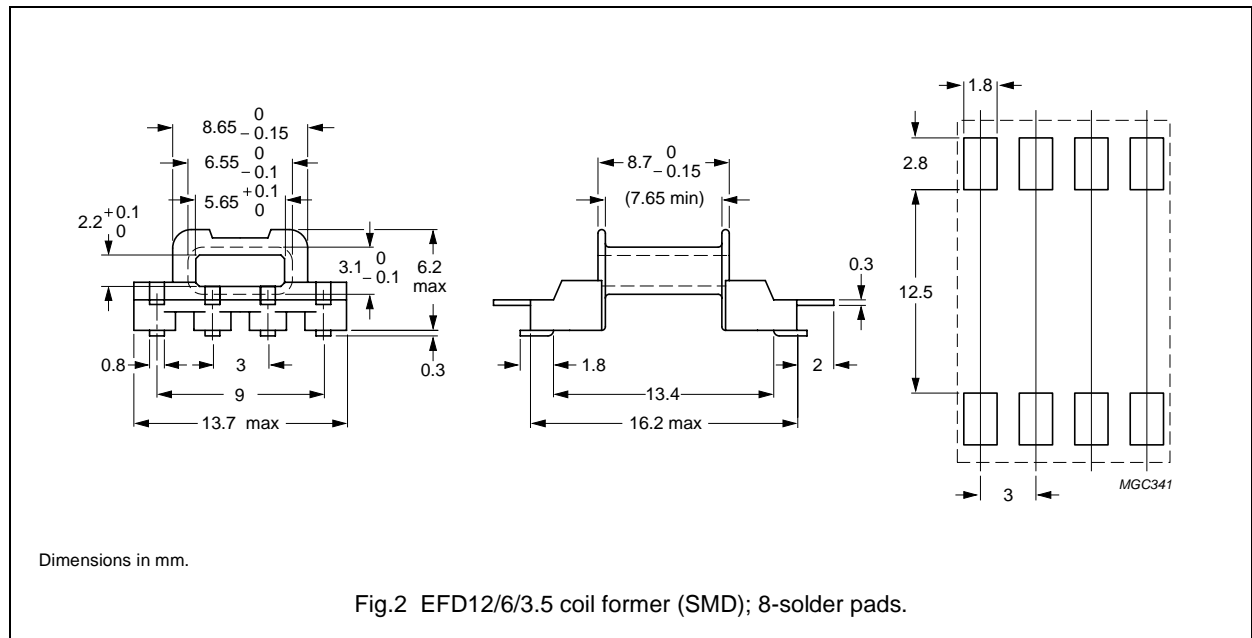

Winding data for EFD12/6/3.5 coil former (SMD) with 8-solder pads

NUMBER OF SECTIONS	NUMBER OF SOLDER PADS	MINIMUM WINDING AREA (mm ²)	MINIMUM WINDING WIDTH (mm)	AVERAGE LENGTH OF TURN (mm)	TYPE NUMBER
1	8	6.5	7.65	18.6	CPHS-EFD12-1S-8P-Z

MOUNTING PARTS

General data

ITEM	REMARKS	FIGURE	TYPE NUMBER
Clamp	stainless steel (CrNi); clamping force ≈ 20 N	3	CLM-EFD12

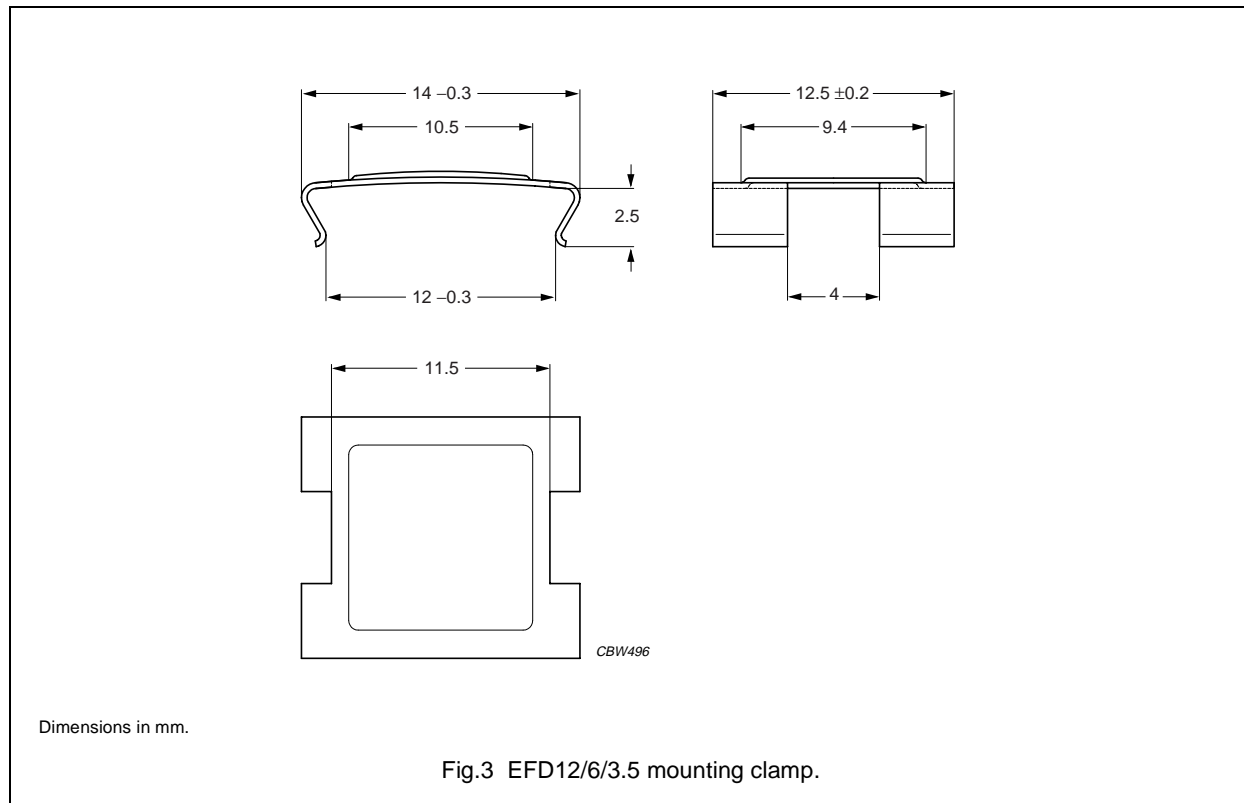



DATA SHEET STATUS DEFINITIONS

DATA SHEET STATUS	PRODUCT STATUS	DEFINITIONS
Preliminary specification	Development	This data sheet contains preliminary data. Ferroxcube reserves the right to make changes at any time without notice in order to improve design and supply the best possible product.
Product specification	Production	This data sheet contains final specifications. Ferroxcube reserves the right to make changes at any time without notice in order to improve design and supply the best possible product.

DISCLAIMER

Life support applications — These products are not designed for use in life support appliances, devices, or systems where malfunction of these products can reasonably be expected to result in personal injury. Ferroxcube customers using or selling these products for use in such applications do so at their own risk and agree to fully indemnify Ferroxcube for any damages resulting from such application.

PRODUCT STATUS DEFINITIONS

STATUS	INDICATION	DEFINITION
Prototype		These are products that have been made as development samples for the purposes of technical evaluation only. The data for these types is provisional and is subject to change.
Design-in		These products are recommended for new designs.
Preferred		These products are recommended for use in current designs and are available via our sales channels.
Support		These products are not recommended for new designs and may not be available through all of our sales channels. Customers are advised to check for availability.