

Instructions



**016-1983-01, 016-1985-01, and 016-1988-01
and above Rackmount Kits**

075-0904-03

Warning

The servicing instructions are for use by qualified personnel only. To avoid personal injury, do not perform any servicing unless you are qualified to do so. Refer to all safety summaries prior to performing service.

www.tektronix.com



075090403

Copyright © Tektronix. All rights reserved. Licensed software products are owned by Tektronix or its subsidiaries or suppliers, and are protected by national copyright laws and international treaty provisions.

Tektronix products are covered by U.S. and foreign patents, issued and pending. Information in this publication supercedes that in all previously published material. Specifications and price change privileges reserved.

TEKTRONIX and TEK are registered trademarks of Tektronix, Inc.

Contacting Tektronix

Tektronix, Inc.
14200 SW Karl Braun Drive
P.O. Box 500
Beaverton, OR 97077
USA

For product information, sales, service, and technical support:

- In North America, call 1-800-833-9200.
- Worldwide, visit www.tektronix.com to find contacts in your area.

Service Safety Summary

Only qualified personnel should perform service procedures. Read this *Service Safety Summary* and the *General Safety Summary* before performing any service procedures.

Do Not Service Alone. Do not perform internal service or adjustments of this product unless another person capable of rendering first aid and resuscitation is present.

Disconnect Power. To avoid electric shock, switch off the instrument power, then disconnect the power cord from the mains power.

Use Care When Servicing With Power On. Dangerous voltages or currents may exist in this product. Disconnect power, remove battery (if applicable), and disconnect test leads before removing protective panels, soldering, or replacing components.

To avoid electric shock, do not touch exposed connections.

Kit Description

This document supports Tektronix DPO7000, DPO70000, DSA70000, and AWG7000 Series instruments.

The rackmount kit is a collection of parts that, once installed, configure the instrument for mounting into a standard 19-inch equipment rack.

Products

DPO7000 Series	All (configuration 1)
DPO70000 Series	All (configuration 2)
DSA70000 Series	All (configuration 2)
AWG7000 Series	All (configuration 3)
AWG5000 Series	All (configuration 3)

Minimum Tool and Equipment List

Required tools and equipment	Part number
Screw Driver, Phillips, #2	Standard tool
T-15 Torx tip	Torx-driver tip for T-15 size screw heads
Screwdriver handle (magnetic)	Accepts 1/4 inch hex-head driver tips

Kit Parts List

This table lists the parts for each kit. You receive the parts for only the kits you ordered.

Kit	Quantity	Part number	Description
All	1 ea.	075-0904-03	Technical manual, instructions
016-1983-xx	1 ea.	016-1983-xx	Rackmount kit consisting of the following:
	1 ea.	-----	Rackmount kit
	2 ea.	-----	Rack, Trim plate
016-1985-xx	1 ea.	016-1985-xx	Rackmount kit consisting of the following:
	1 ea.	-----	Rackmount kit
	2 ea.	-----	Rack, Trim plate

Kit	Quantity	Part number	Description
016-1988-xx	1 ea.	016-1988-xx	Rackmount kit consisting of the following:
	1 ea.	- - - - -	Rackmount kit
	2 ea.	- - - - -	Rack, Trim plate

Warranted Characteristics

When the instrument is installed according to the instructions in this document, the rackmounted instrument meets all warranted requirements listed in the instrument specification. Instruments mounted using methods other than those described in these instructions might not meet their warranted requirements.

For tables of the warranted characteristics, see *Specification* in the specification and performance verification manual that applies to your instrument model.

Cooling air enters on the bottom as shown in Figure 1. You assume the responsibility to provide adequate cool air to meet the ambient temperature requirements listed in the specifications.

Clearance Requirements

The rack in which the rack adapted instrument is mounted must provide the following clearance requirements:

- Configuration 1 and 2, a minimum of 311.15 mm (12.25 in) of vertical space.
- Configuration 3, a minimum of 266.7 mm (10.5 in) of vertical space.
- A minimum width of 450 mm (17.717 in) between the left- and right-front rails in the rack.
- A minimum inside depth of at least 520.7 mm (20.5 in).



CAUTION. Adhering to these requirements mounts the rack-adapted instrument with sufficient clearance for air circulation and accommodation of the power cord and mounting hardware. Failure to provide these clearances can result in overheating and can cause the instrument to operate improperly or fail.

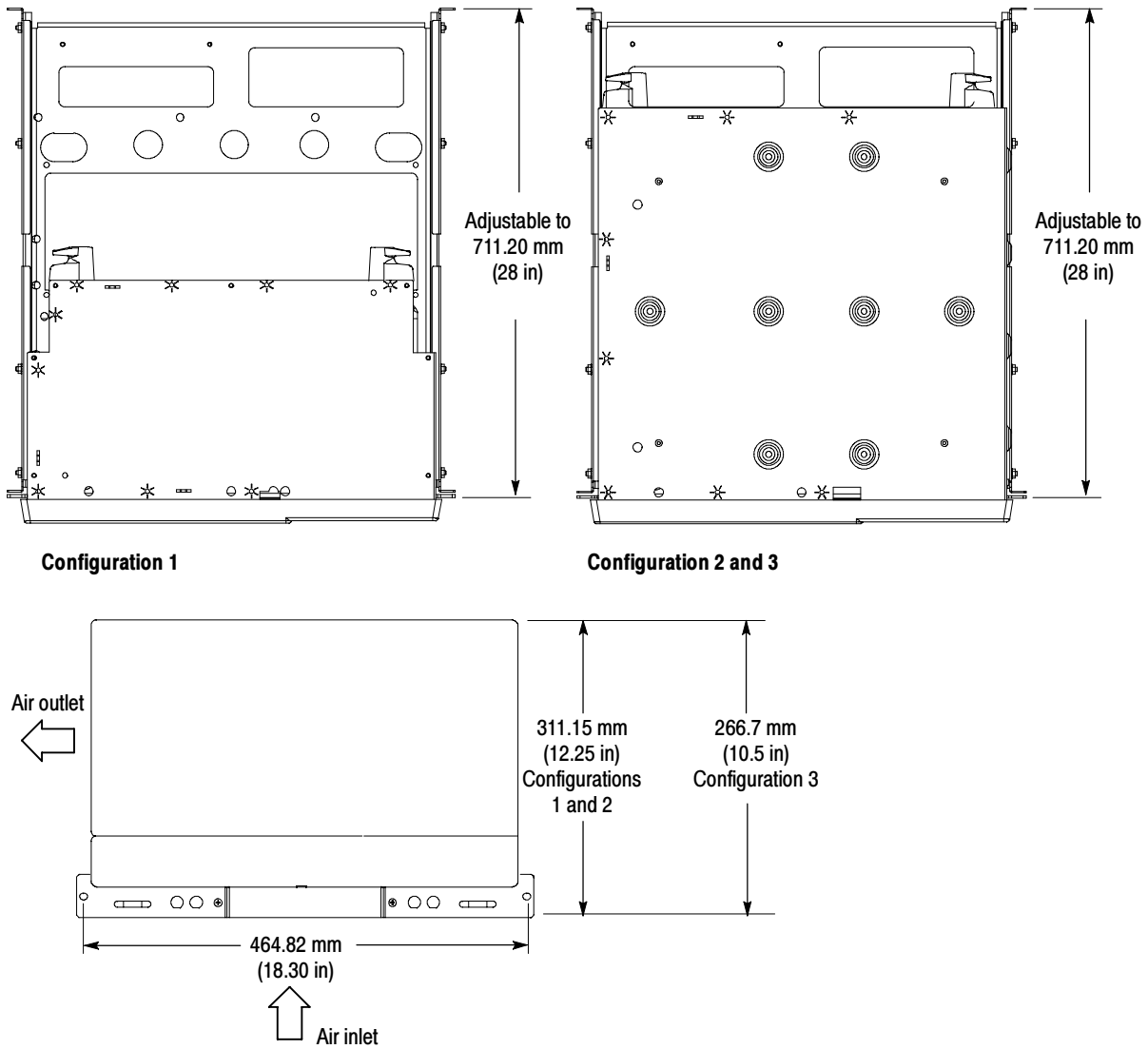

Figure 1: Clearance requirements

Installation Instructions

These instructions are for qualified service personnel who are familiar with servicing the product. If you need further details for disassembling or reassembling the product, refer to the appropriate product manual. Contact your nearest Tektronix, Inc., Service Center or Tektronix Factory Service for installation assistance.

Remove

Remove the handle and trim as shown in Figure 2.

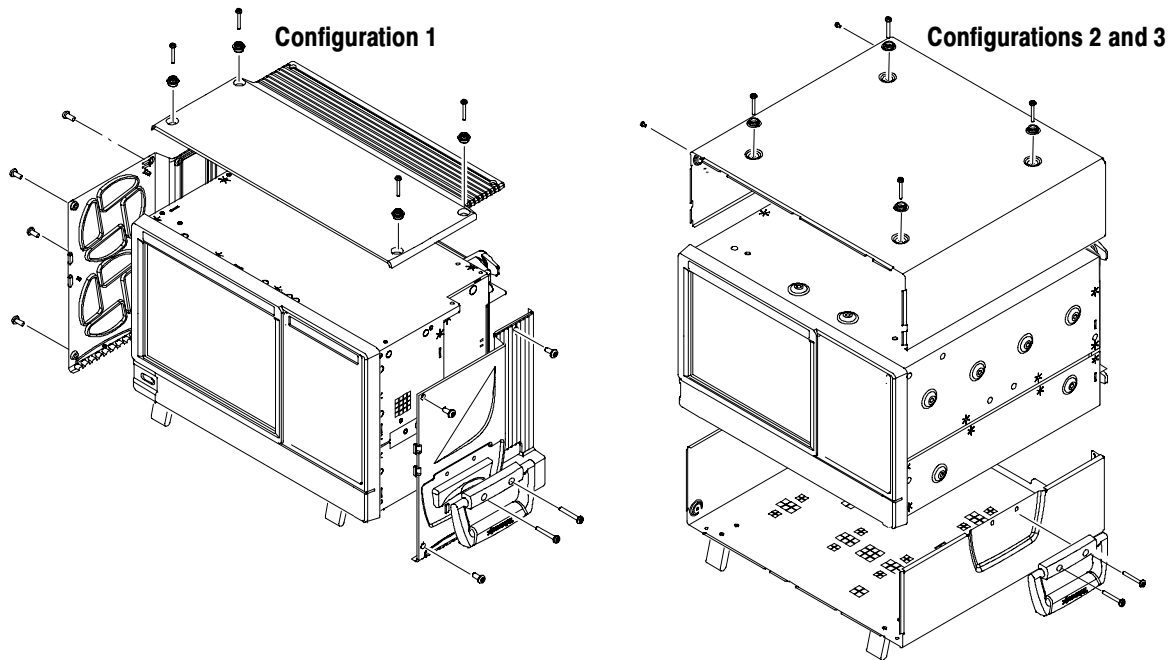

Figure 2: Remove handle and trim

Install

Install the adapter bracket in your rack platform as shown in figures 3 and 4:

NOTE. Configuration 3 has additional spacer rails.

1. Install the adapter bracket.

NOTE. Install the adapter bracket only if you plan to install a Teklink Hub.

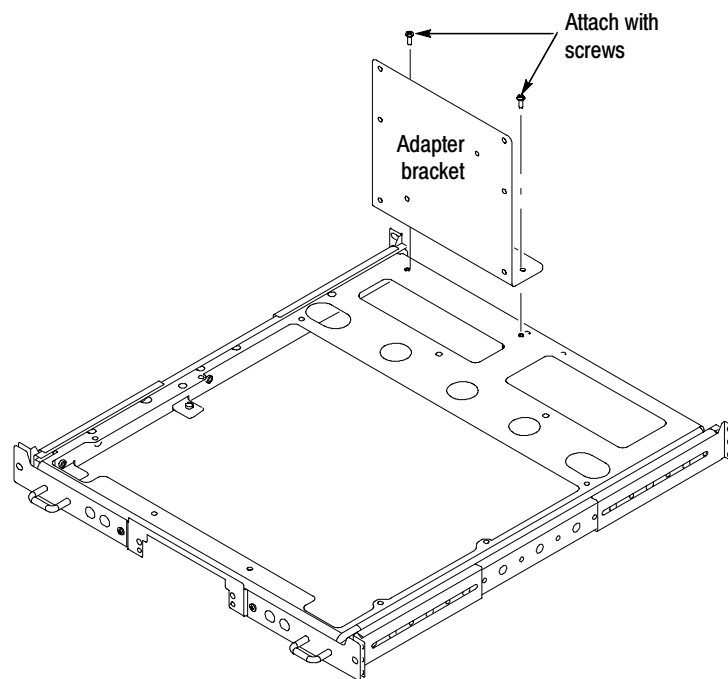

Figure 3: Assembly installation (configurations 1 and 2 shown)

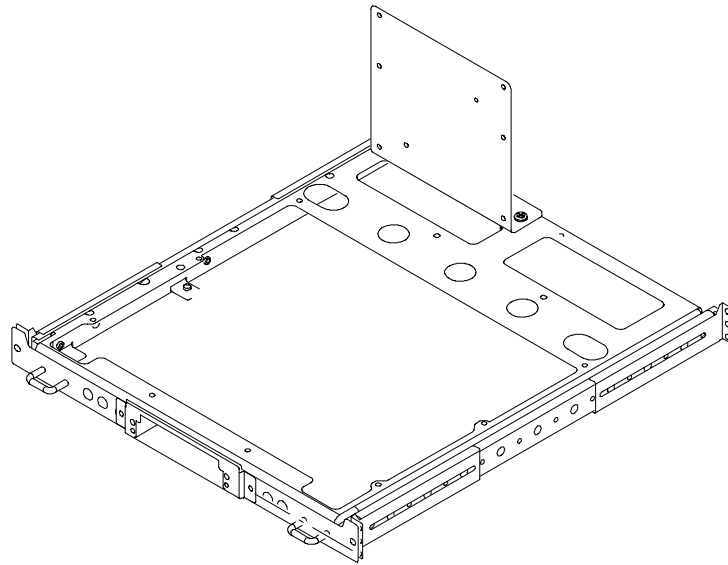

Figure 4: Assembly installation (configurations 1 and 2 shown)

Reassemble

1. Remove the rack slides. See Figure 5.

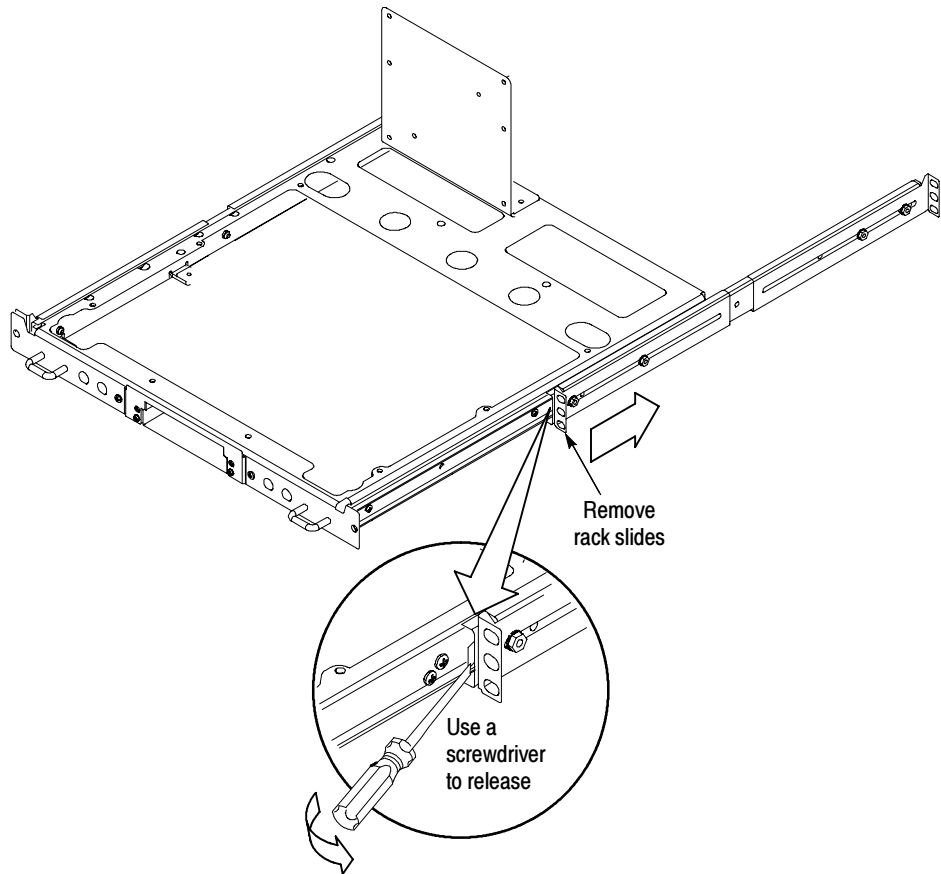

Figure 5: Removing the rack slides (configurations 1 and 2 shown)

2. Attach the rack slides to your equipment rack. See Figure 6.

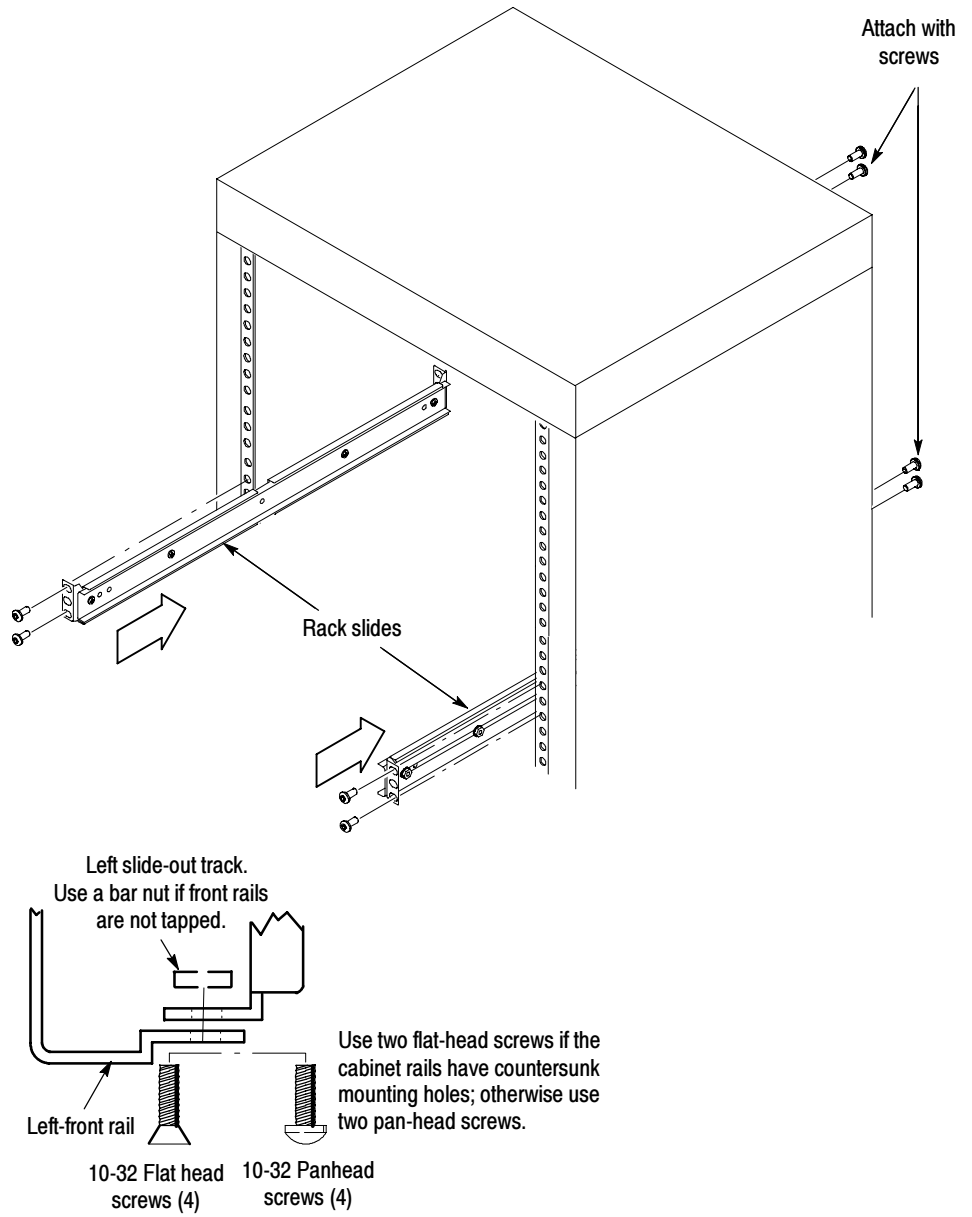

Figure 6: Installing the rail slides

3. Install the rack platform in your equipment rack by inserting the platform into the slides as shown in Figure 7.

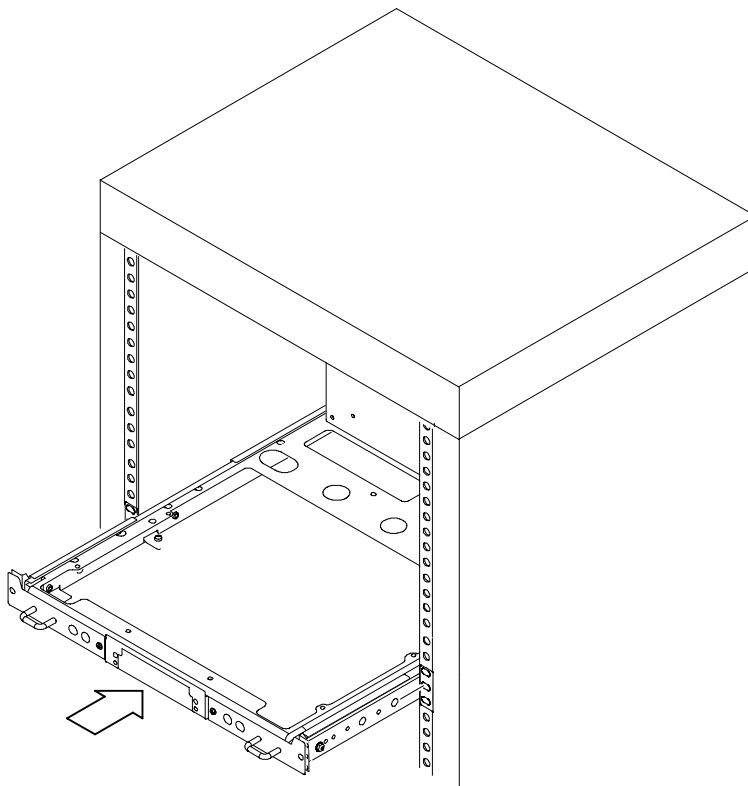

Figure 7: Installation of rack plate assembly in rack (top view) (configurations 1 and 2 shown)



WARNING. To avoid personal injury, prevent the instrument from tipping or dropping, two or more people should install this instrument into the rack cabinet.

After completing the installation procedure, verify that the instrument and the rack cabinet will not tip forward while the instrument is in the extended position.

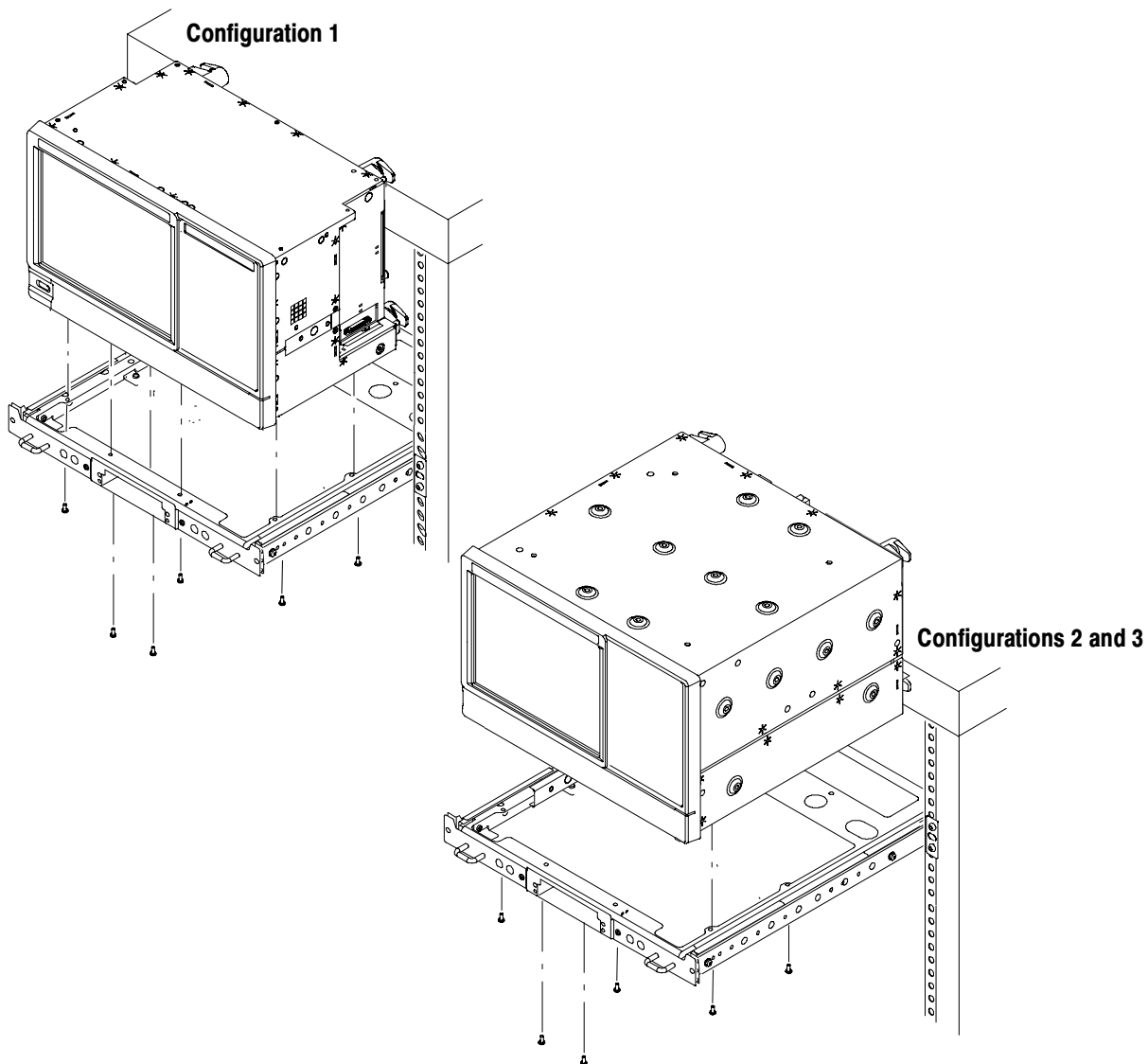

Figure 8: Installing the instrument on the rack plate

4. Install your instrument on the rack plate as shown in Figure 8.
5. Install the power cord. Provide access to a power plug or mains disconnect switch for turning the instrument on/off.
6. Optionally install any cables you need connected to the instrument rear or side panels.
7. Slide the instrument into the equipment rack.
8. Install the appropriate trim plates as shown in Figure 9.

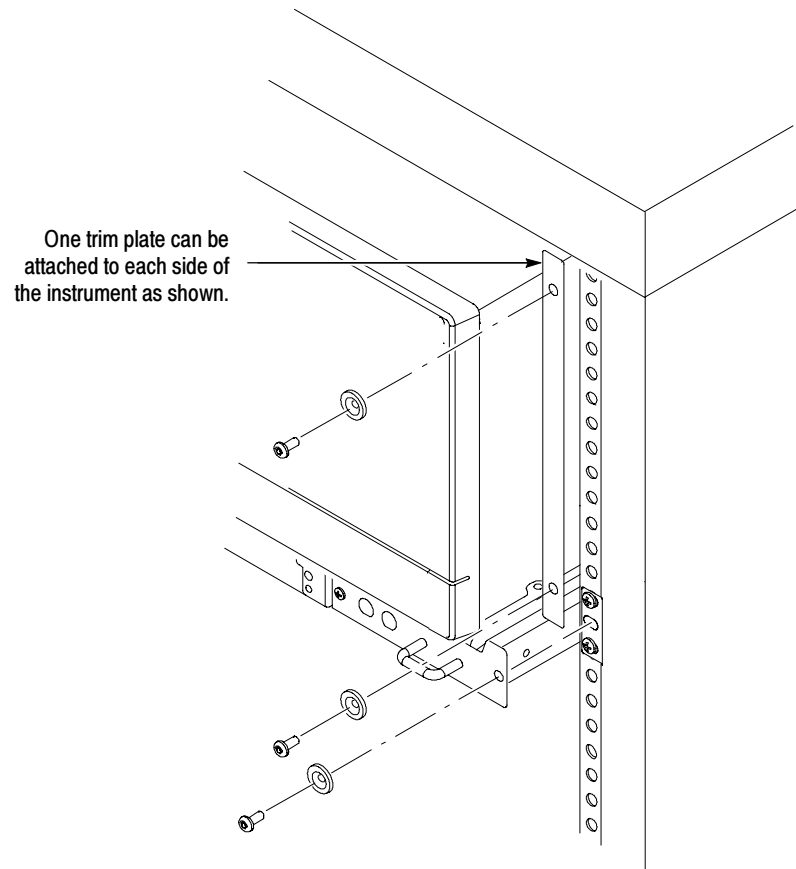

Figure 9: Installation of trim plate

■ End of document ■