

ZDR: Time-switch

For fully automatic switching (on, off or change-over) of circuits such as lighting, heating, ventilation, pumps, cooling plant, alarm systems etc. where higher performance is required.

Microprocessor-controlled, fully electronic day and week time-switch. A super-capacitor provides reserve power supply. Potential-free change-over contacts. External memory (available as an accessory) for reading in/out the switching times. Front plate with illuminated LCD panel, keyboard and drawer with operating instructions. Housing with sealable terminal cover, both of yellow thermoplastic. Suitable for fitting onto walls, in control panels (with accessory) or top-hat rail as per DIN/EN 50022. Terminal baseplate with plug-in connector and screwed terminals for wire of up to 6 mm².



T09430

Type	Power	Number of channels	Memory addresses ¹⁾	Weight kg
ZDR 101 F011	230 V~	1	57	0,41
ZDR 102 F021	230 V~	2	58	0,43

Power supply 230 V~	± 10%, 50...60 Hz	Permissible limit values:-	
Power consumption	approx. 0,6 W (1,2 VA)	Contact rating	16 (6) A, 250 V~
Functional data:-		Ambient conditions:-	
Back-up power supply 20 °C	approx. 36 h	Permissible ambient temp.	-5...35 °C
Accuracy	± 0.4 (sec per day)	Degree of protection	IP 41 (EN 60529)
Shortest switching interval	1 min	Protection class	II (IEC 60730)
Pulse duration	2 s	Wiring diagram	ZDR 101 A01090 ZDR 102 A03089
		Dimension drawing	M275250
		Operating instructions ²⁾	505105 . . .

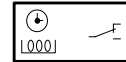

Y03175

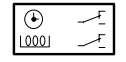

Y03090

Accessories

- 0226187 001*** External memory
- 0226187 002*** Plug-in dummy for memory slot (empty, as a cover)
- 0275490 000** Frame for panel mounting
- 0226327 001** Sealable transparent cover

¹⁾ Dimension drawing or wiring diagram are available under the same number

- 1) If blocks with validity for Mo-Su are formed, there are 399 memory addresses (single-channel) or 406 memory addresses (dual-channel).
- 2) In 6 languages, delivered with each unit. Language code: German = 001; French = 002; English = 003; Italian = 004; Spanish = 005; Swedish = 008.

Operation

The *memotime* is a microprocessor-controlled, fully-electronic time-switch with programmable hour, day and week settings; with LCD display. Applying power across terminals 1 and 2 renders the clock operable.

The bi-stable output relay retains its status even after a power failure, though no switching operations are carried out in such cases. When power is restored, the appropriate switching status is re-instated in accordance with the program.

The switching status can also be set by hand using the ON/OFF buttons. By switching over to TIME, the switching program in the memory is overridden (holiday function) without loss of data.

Functions

- IMPULS Pulsing instead of relay-contact change-over
- 1 x Special-day timer program with automatic reset to AUTO
- CODE Programming block via freely-selectable 4-digit code
- DAILY Daily switching program for seven days
- M Read-in or -out function for the memory
- RESET All individual data are erased
- Display Menu-led LCD function display with time

Operating modes

- TIME Inputs: time, date, summertime/wintertime change-over, absence
- AUTO Automatic operation as per program
- PROG Programming the memory (single-circuit model)
- PROG A Programming the memory for channel A (dual-circuit model)
- PROG B Programming the memory for channel B (dual-circuit model)
- TEST Checking the program in chronological order

Programming

Entries are made on a ten-figure key pad which can be blocked with an entry code. Number of switching commands per week (either as change-over or as pulse):-

- 57 memory addresses on the single-circuit model; 399 switching commands with DAILY
- 58 memory addresses on the dual-circuit model; 406 switching commands with DAILY.

Additional priority programs or single switching times can be programmed up to 6 days in advance (e.g. holidays, periods of absence or party times).

Additional technical data

Complies with:-	
Directive 2006/95/EC	EN 60730-1/ EN 60730-2-7
EMC directive 2004/108/EC	EN 61000-6-1/ EN 61000-6-2
	EN 61000-6-3/ EN 61000-6-4

Fitting instructions

After electrical connection has been made via the terminal socket, the device can be inserted and secured with a sealable screw.

Wiring diagrams

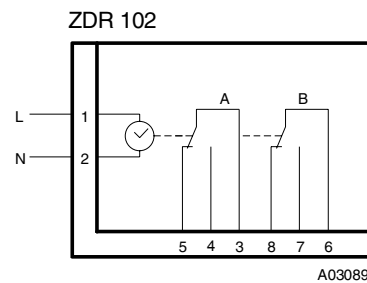
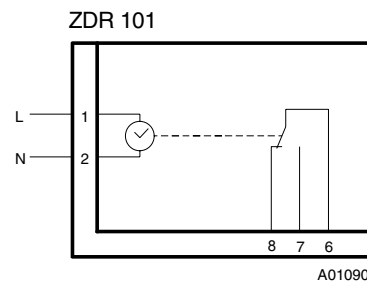

Dimension drawing

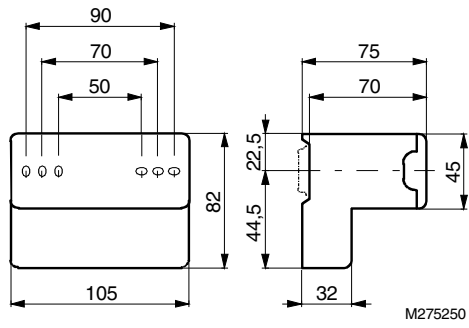

Accessories

226187

