

Installation and Mounting Instruction Sheet for LAMBDA Model LDIN1000

The LAMBDA JFS SERIES of power supplies is designed for industrial applications. An optional mounting method can be accomplished by utilizing an adapter bracket available from LAMBDA for DIN Rail Systems. The LDIN1000 is intended for DIN rail mounting of the JFS0750 and JFS1000 series.

A typical DIN rail mounting application with the required fastening hardware for the LDIN1000 is shown below:

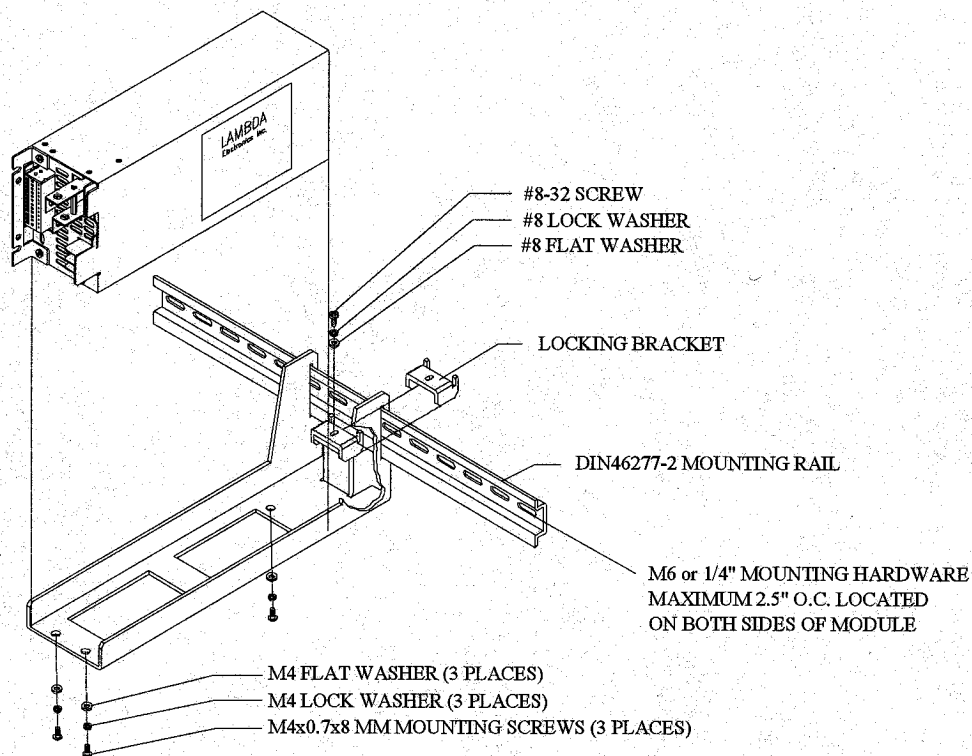

Mounting Sequence:

- 1 - Hang chassis bracket on DIN rail;
- 2 - Mount locking bracket to secure chassis bracket to DIN rail;
- 3 - Mount JFS0750 or JFS1000 power supply to chassis bracket with (3) M4x0.7x8mm screws and corresponding washers.