



ALL RIGHTS RESERVED. NO PORTION OF THIS PUBLICATION, WHETHER IN WHOLE OR IN PART CAN BE REPRODUCED WITHOUT THE EXPRESS WRITTEN CONSENT OF SPC TECHNOLOGY.

SPC-F005.DWG

REVISIONS

DOC. NO. SPC-F005 \* Effective: 7/8/02 \* DCP No: 1398

DCP #	REV	DESCRIPTION	DRAWN	DATE	CHECKD	DATE	APPRVD	DATE
1386	A	RELEASED	HO	5/6/04	LS	8/2/04	JC	8/3/04

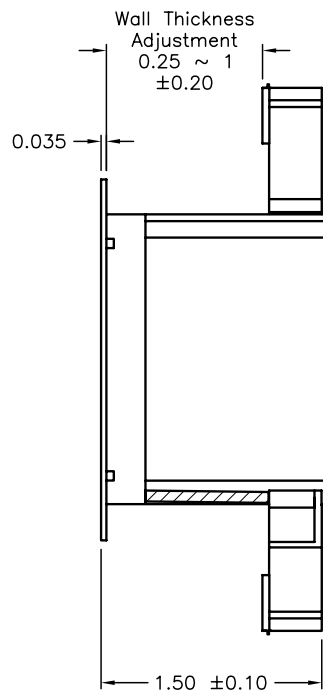
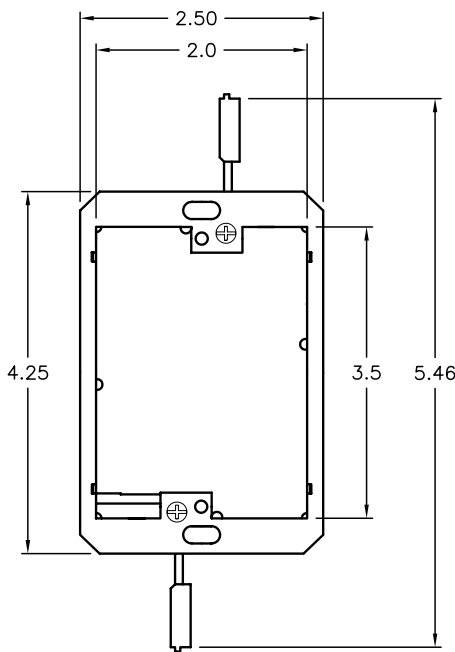

Specifications:

- Non-conductive, smooth plastic construction
- For communications, cable TV, computer wiring
- CAT 5 listed
- Adjusts to fit 1/4" to 1" thick wallboard, paneling or drywall
- Bracket is its own template for cut out
- Specially designed wing flips up when mounting screw is tightened for a secure mount
- Mounts low voltage Class 2 wiring devices to existing wall
- Recessed screw hole-seats wall plate flush with surface
- Oval shape allows final shifting and straightening of device
- Completely assembled, one-piece construction
- May be mounted horizontally or vertically

DISCLAIMER:  
ALL STATEMENTS AND TECHNICAL INFORMATION CONTAINED HEREIN ARE BASED UPON INFORMATION AND/OR TESTS WE BELIEVE TO BE ACCURATE AND RELIABLE. SINCE CONDITIONS OF USE ARE BEYOND OUR CONTROL, THE USER SHALL DETERMINE THE SUITABILITY OF THE PRODUCT FOR THE INTENDED USE AND ASSUME ALL RISK AND LIABILITY WHATSOEVER IN CONNECTION THEREWITH.

TOLERANCES:  
UNLESS OTHERWISE SPECIFIED, DIMENSIONS ARE FOR REFERENCE PURPOSES ONLY.

DRAWN BY:	DATE:
HISHAM ODISH	5/6/04
CHECKED BY:	DATE:
LUIS SERBIA	8/2/04
APPROVED BY:	DATE:
JOHN COLE	8/3/04

DRAWING TITLE: Quick Mounting Bracket For Existing Wall, Single Gang			
SIZE	DWG. NO.	ELECTRONIC FILE	REV
A	SPC5344	50N101.DWG	A
SCALE:	NTS	U.O.M.: INCHES	SHEET: 1 OF 1