

REVISIONS			DOC. NO. SPC-F004 * Effective: 7/8/02 * DCP No: 1398						
DCP #	REV	DESCRIPTION	DRAWN	DATE	CHECKD	DATE	APPRVD	DATE	
564	A	RELEASED	HYO	3/24/00	JC	11/21/00	DJC	12/1/00	
1892	B	Update To RoHS Compliant	EO	3/14/06	HO	3/15/06	HO	3/15/06	

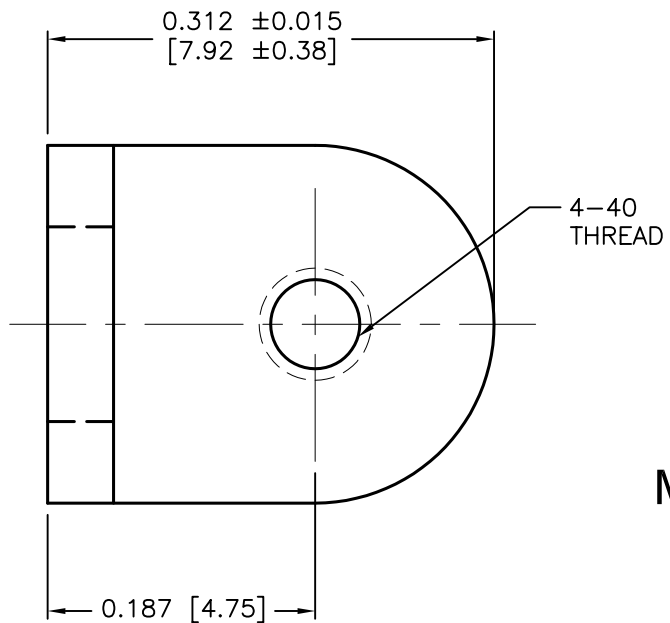

MATERIAL: BRASS, TIN PLATED

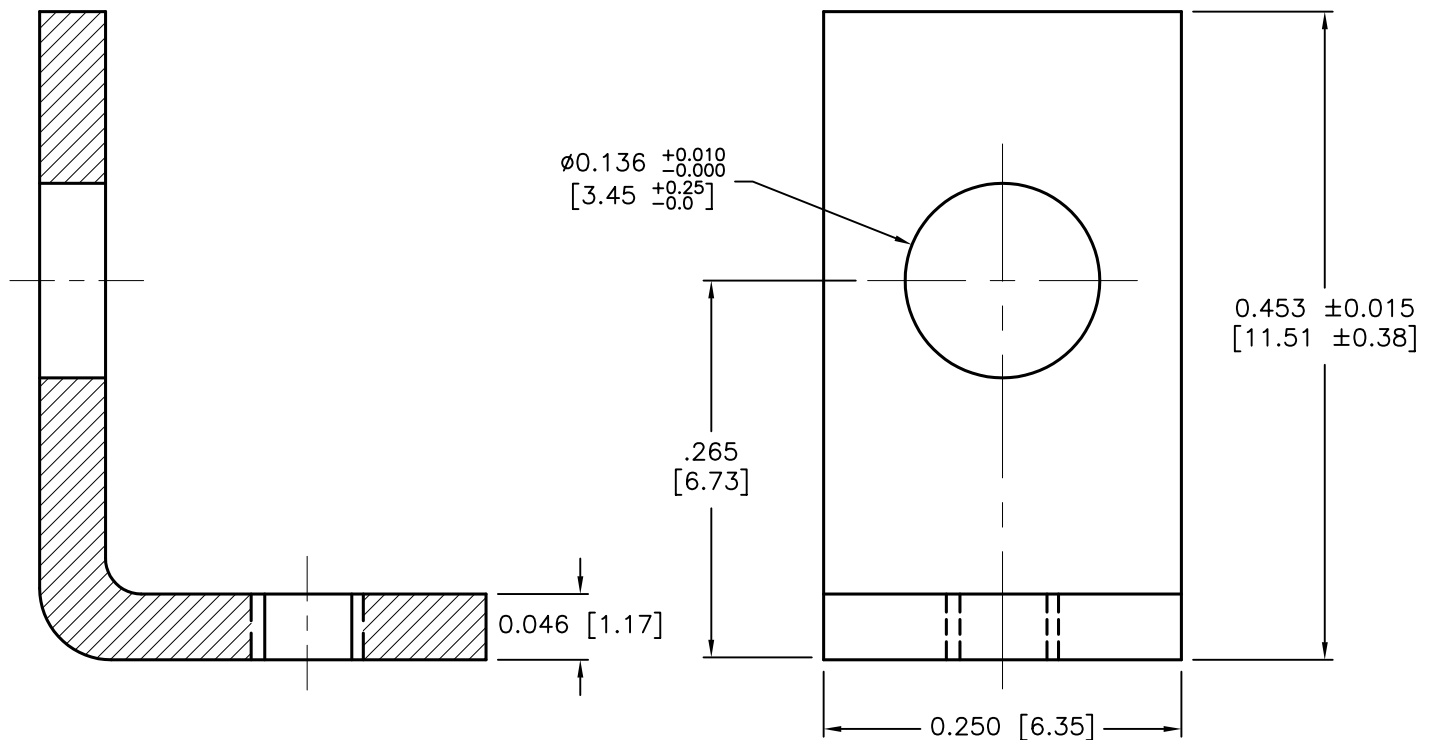

SPC-F004.DWG

TOLERANCES: UNLESS OTHERWISE SPECIFIED DECIMAL .XXX ± 0.010 [.250]	DRAWN BY: HISHAM ODISH	DATE: 3/24/00	DRAWING TITLE: THREADED MOUNTING BRACKET			
	CHECKED BY: JOHN COLE	DATE: 11/21/00	SIZE A	DWG. NO. 8459-0667	ELECTRONIC FILE 16N949.DWG	REV B
	APPROVED BY: DANIEL CAREY	DATE: 12/1/00	SCALE: NTS		U.O.M.: INCHES	
					SHEET: 1 OF 1	

ALL RIGHTS RESERVED. NO PORTION OF THIS PUBLICATION, WHETHER IN WHOLE OR IN PART CAN BE REPRODUCED WITHOUT THE EXPRESS WRITTEN CONSENT OF SPC TECHNOLOGY. DISCLAIMER: ALL STATEMENTS AND TECHNICAL INFORMATION CONTAINED HEREIN ARE BASED UPON INFORMATION AND/OR TESTS WE BELIEVE TO BE ACCURATE AND RELIABLE. SINCE CONDITIONS OF USE ARE BEYOND OUR CONTROL, THE USER SHALL DETERMINE THE SUITABILITY OF THE PRODUCT FOR THE INTENDED USE AND ASSUME ALL RISK AND LIABILITY WHATSOEVER IN CONNECTION THEREWITH.