



ALL RIGHTS RESERVED. NO PORTION OF THIS PUBLICATION, WHETHER IN WHOLE OR IN PART, CAN BE REPRODUCED WITHOUT THE EXPRESS WRITTEN CONSENT OF SPC TECHNOLOGY.

SPC-F005.DWG

REVISIONS

DOC. NO. SPC-F005 * Effective: 7/8/02 * DCP No: 1398

DCP #	REV	DESCRIPTION	DRAWN	DATE	CHECKD	DATE	APPRVD	DATE
564	A	RELEASED	DJC	11/17/98	JC	1/22/99	JWM	1/29/99
1892	B	UPDATE TO ROHS COMPLIANT	EO	03/15/06	HO	3/15/06	HO	3/15/06

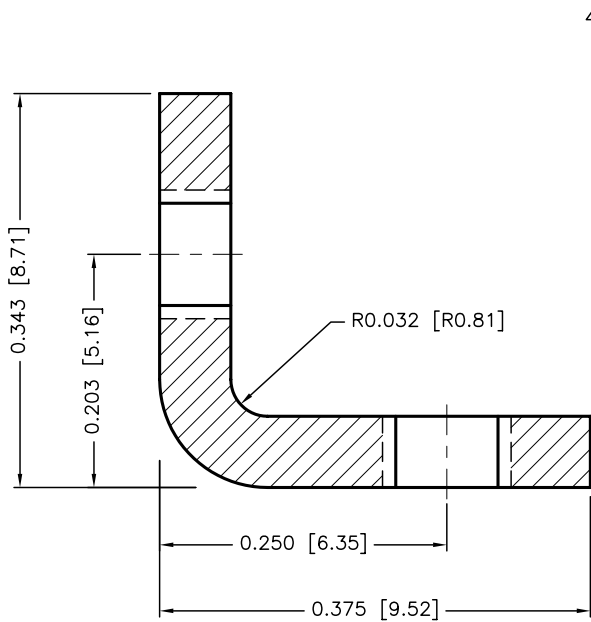

4-40 THREAD
(2) PLS

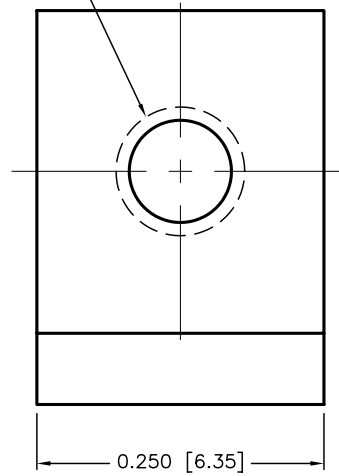

SPECIFICATIONS

- MATERIAL: 0.062 [1.57] Thick Steel
- FINISH: Zinc Plate

DISCLAIMER:
ALL STATEMENTS AND TECHNICAL INFORMATION CONTAINED HEREIN ARE BASED UPON INFORMATION AND/OR TESTS WE BELIEVE TO BE ACCURATE AND RELIABLE. SINCE CONDITIONS OF USE ARE BEYOND OUR CONTROL, THE USER SHALL DETERMINE THE SUITABILITY OF THE PRODUCT FOR THE INTENDED USE AND ASSUME ALL RISK AND LIABILITY WHATSOEVER IN CONNECTION THEREWITH.

TOLERANCES:

UNLESS OTHERWISE SPECIFIED
DECIMAL: ±.010 [±0.25]
ANGULAR: ±1/2°

DRAWN BY:	DATE:
DANIEL CAREY	11/17/98
CHECKED BY:	DATE:
JOHN COLE	1/22/99
APPROVED BY:	DATE:
JEFF MCVICKER	1/29/99

DRAWING TITLE:

THREADED MOUNTING BRACKET

SIZE	DWG. NO.	ELECTRONIC FILE	REV
A	8459-0666	16N948.DWG	B
SCALE: NTS	U.O.M.: INCHES [mm]	SHEET: 1 OF 1	