

System 250 Data Sheet



The new BOFA system 250 is a compact high volume unit designed to extract fumes through a variety of extraction accessories. The system comes complete with a user friendly installation kit allowing instant extraction for minimum fuss and cost.

Carcass

Main body, central support, lid and base are powder coated Zintac

Standard Equipment

Weight: 10kg
 Filter Indication light
 Noise level: below 55dba
 Integral silencer with air exhausted out the base of unit
 Standard Filter set (see below)
 2 x 50mm Diameter inlet
 Thermal trip
 System 250 Installation Kit (table brackets, Flip-Top connectors, mounting plates, adaptors with balancing valves & flexi tubing)

Electrics

230v 1ph 50hz or 110v 1ph 60hz
 2m Power Cord
 Fused IEC illuminated switch
 Full load current: 1.5 amps

Warranty

12 month warranty
 12 month COSHH Certification (when installed by BOFA engineers)

Standard Filter Set

Pre Filter

95% efficiency @ 0.8micron

Combined Filter

HEPA 99.997% @ 0.3 micron
 Gas Filter media
 Activated carbon impregnated with potassium permanganate

Maximum number of arms

32mm	50mm	75mm
EC: 4	EC: 2	EC: 1
US: 4	US: 2	US: 1

Blower / Pump

Radial Ventilator
 40,000 life hours
 Pressure 40m/bar
 0.12k Output
 Airflow 180m³/hr (with filters fitted)
 IP54 Synchronous (brushless) motor

Options

VOC Monitoring

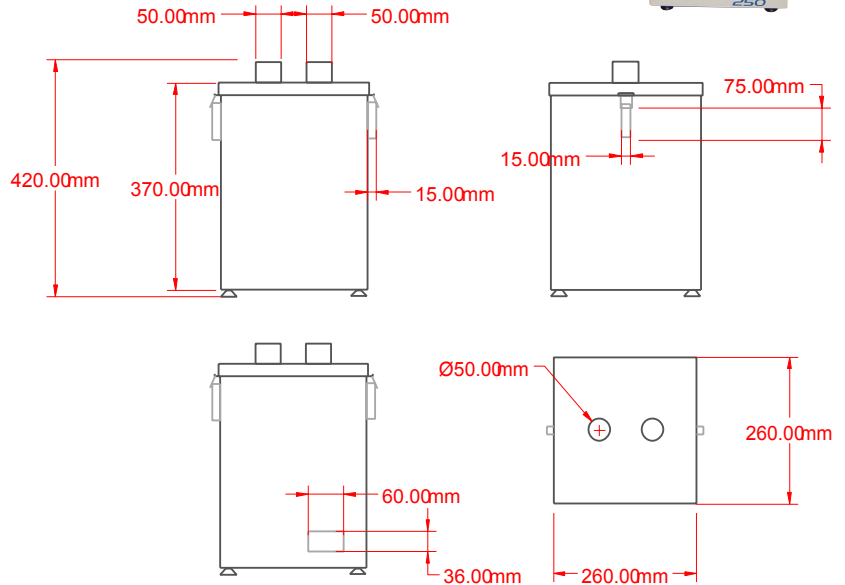

The system 250 comes complete with the □ installation kit shown opposite x 2. □ This includes 3 meters of 50mm flexible tubing, □ 2 x table brackets & mounting plates, □ 2 x flush system seal Flip top connector and □ adaptor with balancing valve.

HEPA Filter

Efficiency 99.997% @ 0.3 micron

Pre Filter

Efficiency 95% @ 0.8 micron

Gas Filter media
 Activated Carbon impregnated with potassium permanganate

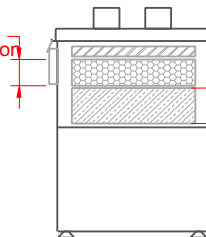

The chart opposite shows the maximum number of soldering arms that the System 250 is capable of extracting from.

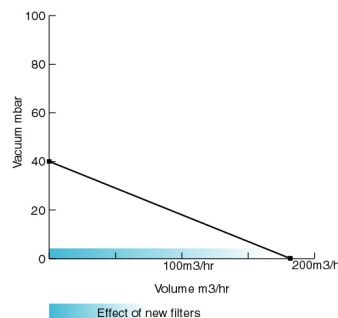
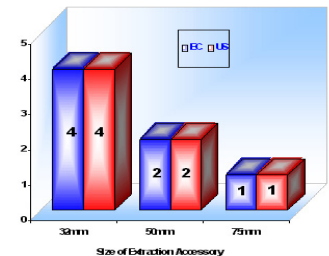

The chart opposite shows the performance of the pump within the System 250. The performance curve also highlights the effect of new filters on the new System 250's vacuum capabilities



Unit 13, Fleetsbridge Business Park, Poole, Dorset, BH17 7AF United Kingdom
 T: +44 (0) 1202 666789 F: +44 (0) 1202 649922

