

**DIC HIGH-PERFORMANCE DESOLDERING TOOL**

**MODEL**

**SC-7000Z**

**OPERATION MANUAL**



**DEN-ON INSTRUMENTS CO.,LTD.**

TOKYO JAPAN

Thank you for your purchase of the DIC SC-7000Z high-performance desoldering tool as one of your service instruments. We hope that the use of our quality product will give you satisfaction for years to come. To get the maximum performance, please note the following instructions before operating the tool. This basic technical sheet will help you to better understand the features, advantage, and maintenance necessary to keep the tool functioning efficient.

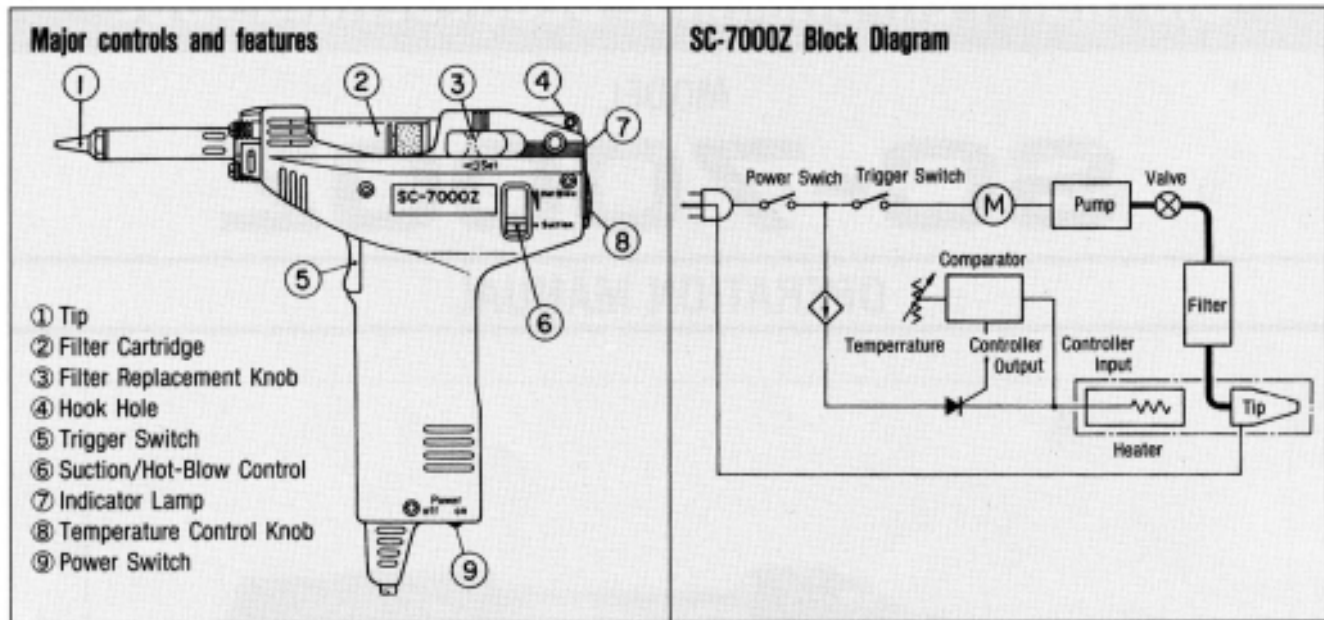

## USAGE

1. Plug the power cord into an electrical outlet. Then set the power switch located on the bottom of handgrip to "ON" position and it will warm up in a few minutes.

**NOTE:**

- a) When SC-7000Z is operated for the first time, fumes may develop in the area of the heater holder. But this is normal because it is caused by the protective coating.
  - b) Check that the filter cartridge is in a proper position and direction.
2. Set the temperature control knob to suit the application. For standard suction procedures, it is advisable to choose a position between 380°C and 420°C. When working on multilayer P.C.B, the most satisfactory results will be obtained at temperatures ranging from 430°C to approx. 450°C
  3. To remove the solder around any lead-wire of a given components, simply place and insert the bore of the suction tip over the wire-end, and at the solder melting, gently pull the vacuum trigger switch to allow the pump to suck the melting solder away.
  4. The removed solder will gradually accumulate in the filter cartridge and should be removed with tweezers from time to time.
  5. When the white felt in the filter cartridge becomes dirty, the suction effect of the system will decrease. It is recommended that the filter cartridge be changed when one-fourth or one-half of the filter shows a build up of impurities.
  6. If the bore of the suction tip becomes clogged with flux and/or solder and causes a decrease in suction performance, it will be necessary to clear the channel, using the cleaning pin set.

**NOTE:** The instrument is delivered with a cleaning pin set composed of 3 different diameter pins to be used according to the suction tip sizes. Each cleaning pin has a long and a short size. Use the short pin first, then followed by the long pin.

7. After a working session, clear the bore of any flux and/or solder residuals, then, set the operating mode lever to the hot-blow position to clean the tip completely. Your tool will now be ready to proceed with your next job.
8. The indicator lamp ⑦ will go on when the heater is on. As the temperature of the tip is higher, so it will be early deteriorated. Lower the temperature when it is in the waiting situation.

## PARTS REPLACEMENT AND MAINTENANCE

### 1. Filter cartridge replacement

When solder material has accumulated in the filter cartridge after a long period of operation, please remove it with tweezers. When one-fourth or one-half of the felt portion has been discolored by dirt, please replace the filter cartridge and filters with new ones.

**NOTE:** When replacing the filter cartridge, be sure to clean adjacent area to prevent the air leakage.

#### Removal and/or replacement procedure

Pull the filter releasing/fixing knob inward (release position). Push the cartridge assembly in direction of mark "◁" and remove it. Place the new cartridge with the sign 'FRONT' upwards into location and bring back the releasing/fixing knob to the 'FIX' position.

Make sure that the knob is properly locked after the replacement.

### 2. Suction Tip and SMD Hot Air Nozzle Replacement

To remove the tip or SMD hot blow nozzle, unscrew it counterclockwise by a wrench on the nut-cut face. Do not overtighten when mounting it again.

### 3. Cleaning and Replacement of Sheet-Valve, Gasket or Diaphragm

After long operation, the suction pump parts, such as sheet valve, gasket and/or diaphragm shall need cleaning or replacement.

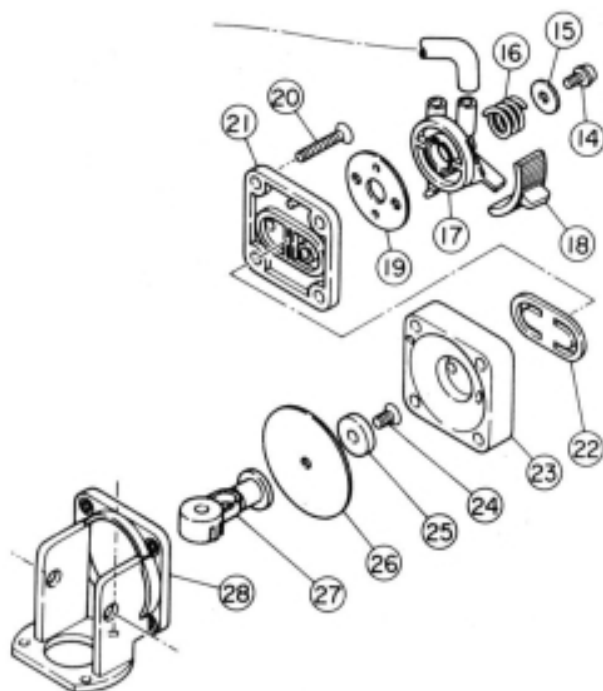

#### Suction Pump Disassembly for Cleaning and Replacement

Loosen and remove three screws on the body housing.

Also, remove the fixing screw located in the base of the heater holder. Open the side of the body housing carrying the sticker. Take the pump unit out of the body.

For cleaning and replacement of gasket (19) and sheet-valve (22), remove the attached screws (14) and (20) respectively. For diaphragm (26) cleaning and replacement, remove the attached screws (20) and (24).

### 4. Heater Replacement

Remove the tip or SMD hot blow nozzle. Open the body housing in the same procedures as described on paragraph 3.

Disconnect the heater circuit plugs from the PCB (37A). Take the heater out of the body housing.

After replacement of the heater, adjust the variable resistor according to the table below.

Heater Wires Color Code	VR Position
Black	A
Red	B
White	C

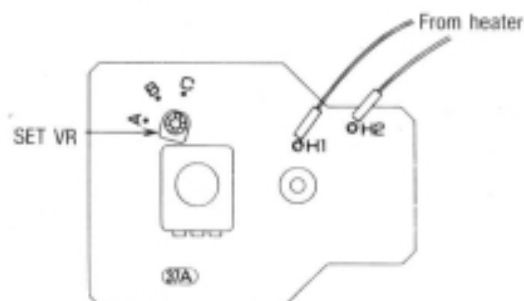

# SCHEMATIC

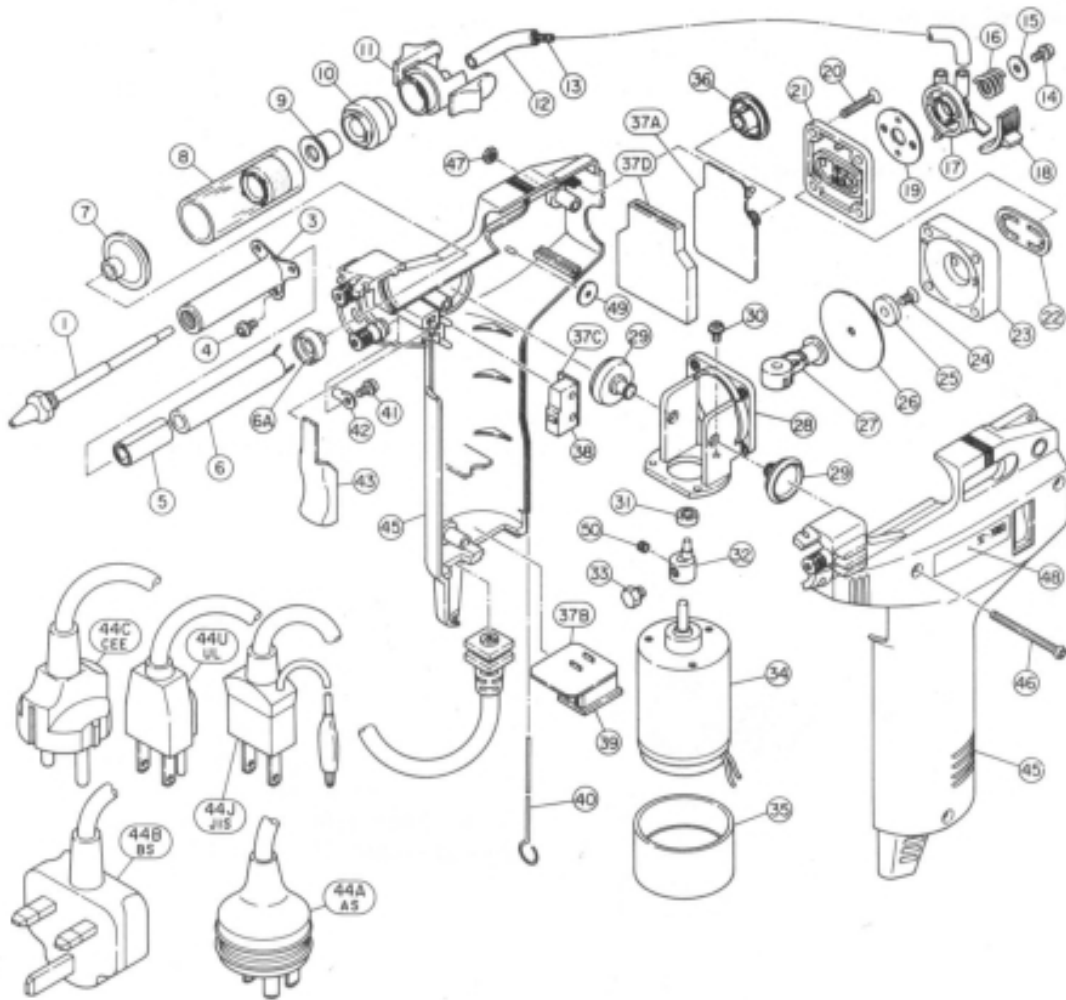

## SPARE PARTS LIST

Please refer the tip to the back cover.

Drawing No.	Order No.	Description	Remarks
3	70-03-00	Heater holder	
6	70-06-00	Heater with insulation tube	100-120 VAC Model
	70-06-50	Heater with insulation tube	220-240 VAC Model
7	50-07-00	Pipe setter (F)	
8	70-08-00	Fiiter cartridge	One set order consists of 5 pcs. of filter cartridge and 5 pcs.of filter-B
		Filter S (Ⓢ in SCHEMATIC)	
19	70-19-00	Gasket	
22	70-22-00	Sheet-Valve	
26	70-26-00	Diaphragm	



## REMOVAL OF 'SURFACE MOUNTED DEVICES' (SMD)

As you are aware, the unique design of the SC-7000Z desoldering tool allows for the quick conversion from a solder suction tool to a hot Blower. By using the hot blower with the SMD kit(72.78.00), the SMD will be easily removed from PCB's. The change to hot blower requires:

- Remove the Suction tip and replace with hot Blow nozzle by a wrench.
- Replace the original cartridge with the hot blow filter pipe.
- Set the lever to hot blow position.





The air flow of the hot-blow can be adjusted with the lever.

- Depending on the nature of the suction work and the size of the component, the temperature control knob should be set at the appropriate level.(450°C-500°C)

**CAUTION:** When using the hot-blow function, Please take care of the hot blow to avoid burns.

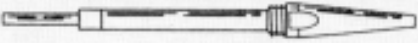
### 'SMD' KIT-OPTIONAL-(Code No.72-78-00)

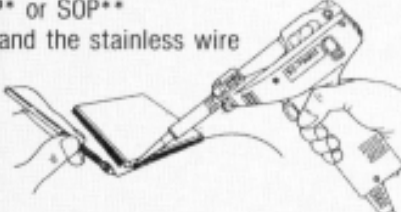
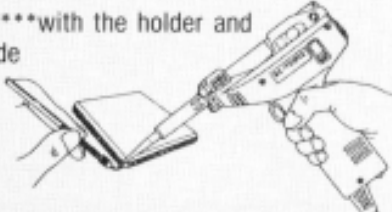
The kit consists of five different items as shown below:

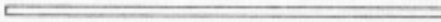
<p>(1)</p>  <p>Hot-Blow Nozzle(72-78-01) (Not to use it for the suction)</p>	<p>Replace the suction tip with the hot blow nozzle.</p>
<p>(2)</p>  <p>Hot-blow filter pipe(72-78-02)</p>	<p>For the use of the hot-blow desoldering applications</p>
<p>(3)</p>  <p>Holder, WH-1(72-78-03)</p>	<p>Removal of QFP* or SOP** with the holder and the stainless wire</p>  <p>Removal of PLCC***with the holder and the stainless blade</p> 
<p>(4)</p> <p>Stainless wire &amp; Blade(72-78-04)</p>  <p>Stainless wire S-1×10pcs</p>  <p>Stainless Blade B-1×3pcs</p>	

\*QFP:Quad Flat Package \*\*SOP:Small Out-line Package \*\*\*PLCC:Plastic Leaded Chip Carrier

## PRECAUTIONS

- Never attempt to wash or rinse a dirty filter in any kind volatile solvent, because this may decrease the performance of the SC-7000Z and may present an explosive hazard.
- To avoid damage to heating element (from thermal shock) never use water or any other coolant on the heating section or the tip.
- Excessive shock and vibration to SC-7000Z may also damage the heating element.
- After extended use, flux may accumulate on the valve sheet, gasket and/or the protective silicon tubing of the vacuum pump thus lowering its suction performance. Periodic maintenance and cleaning of these parts are advisable. Any flawed or deformed parts should be replaced.
- The tool-stand (ST800) should be used in conjunction with SC-7000Z. This particular stand has been designed to maximize the performance and life of SC-7000Z.
- Do not touch the tip or the heater holder in the operation because they are very hot.
- After the solder melted with the SMD kit, it is recommendable to use a glass-made filter pipe(70-08-20) when sucking a long time the melt solder remained on PCB.

# TROUBLE SHOOTING CHART

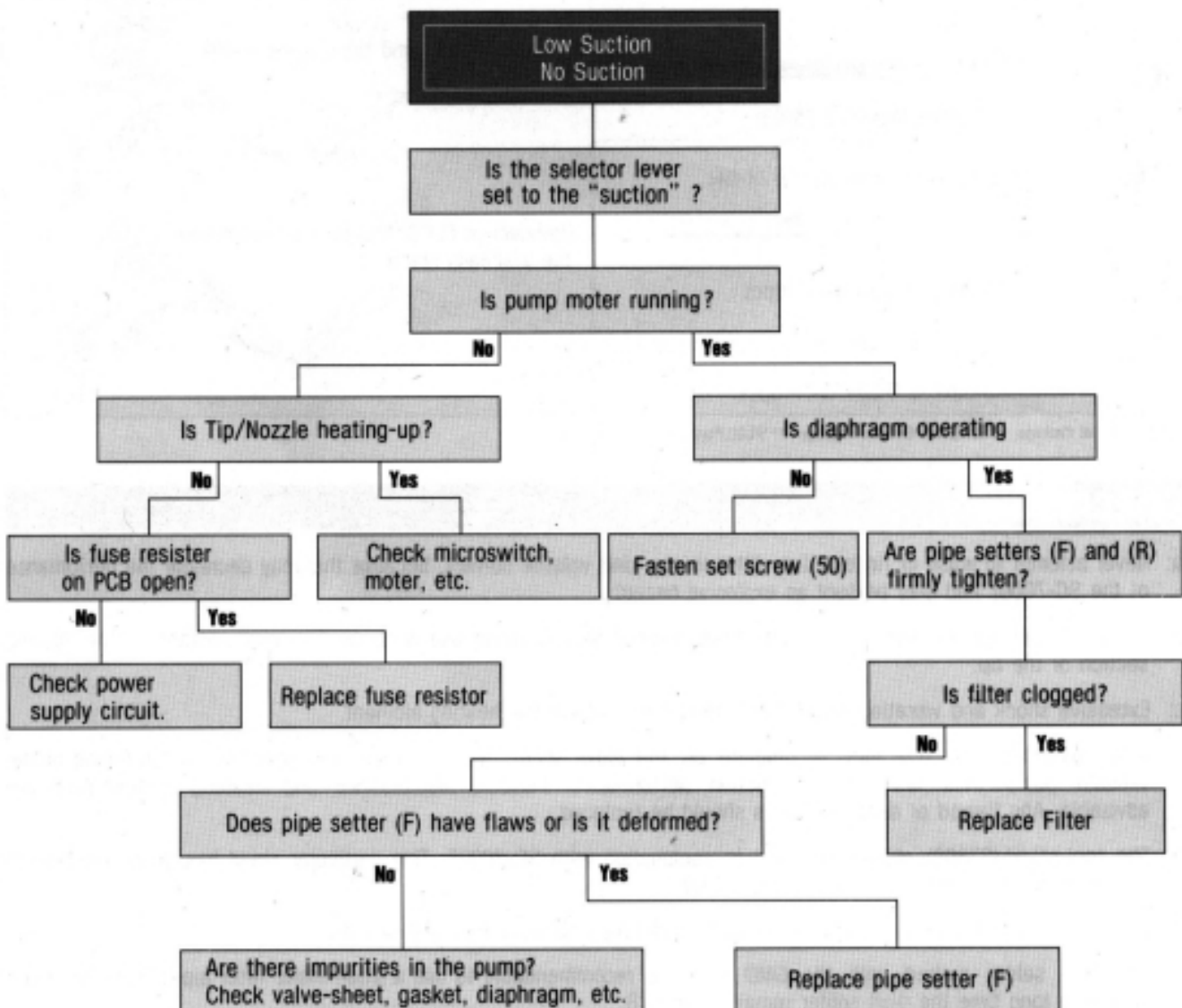
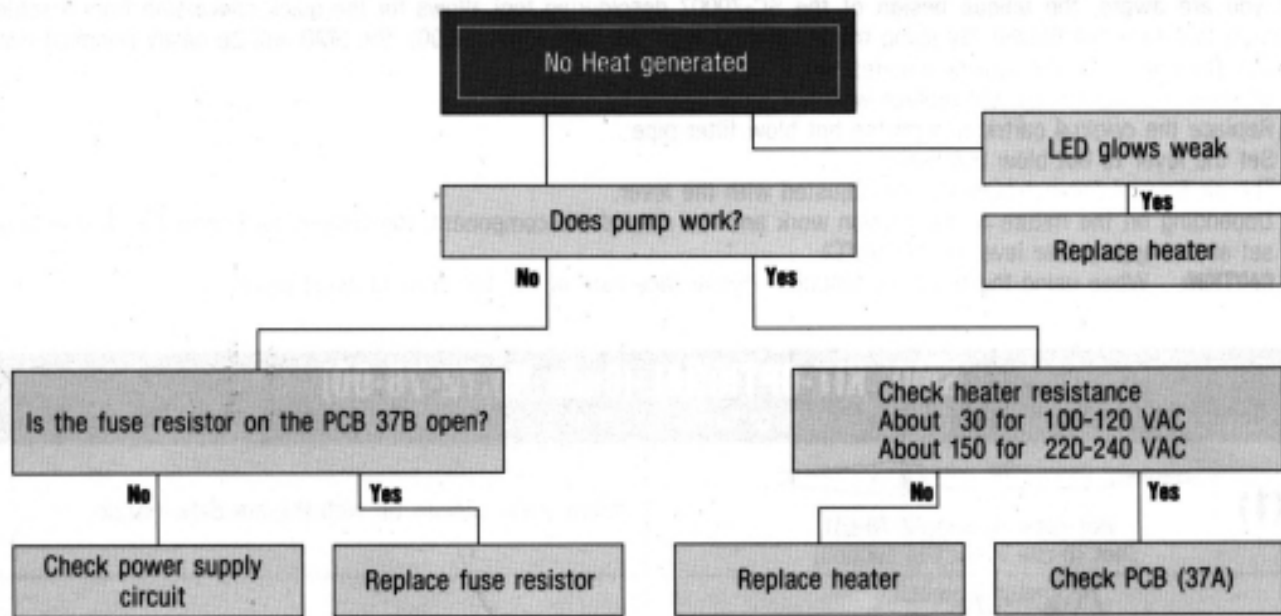





■ TIP (OPTION)

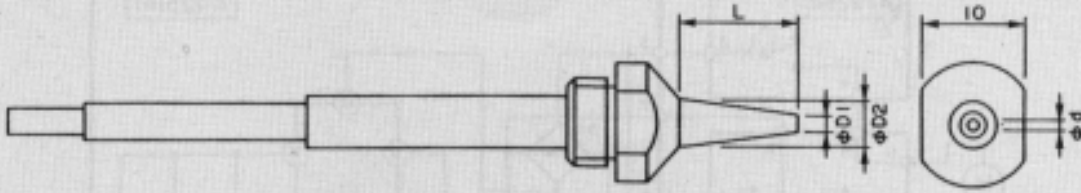

CODE NO.	SPEC.	STAMPED	$\phi\phi d$	$\phi D1$	$\phi D2$	Lmm
50-01-11	0.8Std	0.8	0.8	2.5	7.0	12.5
50-01-12	0.8SLIM	08S	0.8	2.0	6.0	14.0
50-01-13	0.8U SLIM	S8	0.8	1.5	5.0	11.5
※50-01-14	1.0 Std	1.0	1.0	2.5	7.0	12.5
50-01-15	1.5Std	1.5	1.5	3.0	7.0	12.5
50-01-16	1.0 SLIM	10S	1.0	2.0	6.0	14.0
50-01-17	1.5 SLIM	15S	1.5	2.2	6.0	14.0

※One piece of tip 1.0mm (50-01-14) is fitted in the main body.

**NOTE:** The tip will be earlier deteriorated with the use in higher temperature. Please lower the temperature when it is in the waiting situation.



**DEN-ON  
INSTRUMENTS  
CO., LTD.**

1-26-10, SEKIMACHI-HIGASHI, NERIMA, TOKYO, JAPAN  
TEL:[81]3(3929)6000 FAX:[81]3(3929)7441