

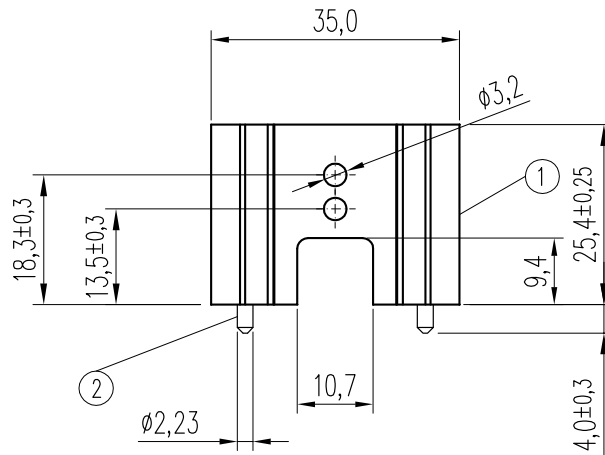

Pos.	Description	Q.ty	P/N
2	PIN-BRASS-D.2,23x15-TIN-BM012 B	2	406072G
1	HTSK-AL-0S172-25,4-B-ML73 6098 STD	1	405128

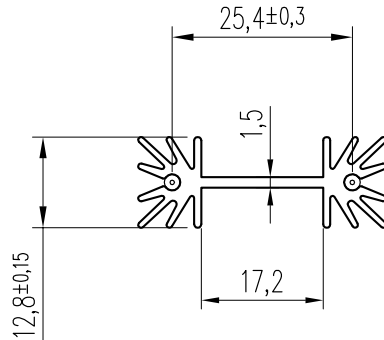

Note:		Scale			
ML73 (S172/25.4 with pins)		1:1			
THIS DOCUMENT CONTAINS AAVID THERMALLOY'S INTELLECTUAL PROPERTY WHICH IS SUPPLIED IN CONFIDENCE; IT MUST NOT BE USED FOR ANY PURPOSE OTHER THAN WHICH IT IS SUPPLIED; IT MUST NOT BE REPRODUCED WITHOUT WRITTEN PERMISSION FROM THE OWNERS		©			
		®			
 AAVID THERMALLOY EUROPE www.aavidthermalloy.com Via XXV Aprile, 32 40057 Cadriano - Bologna ITALY Tel. +39 051 764011 Fax +39 051 764090 Cheney Manor SWINDON WILTS SN2 2QN UK Tel. +44 1793 401400 Fax +44 1793 615396 COMPANY WITH QUALITY SYSTEM CERTIFIED BY LROA ISO 9001:2000	1	B	13Jan05	RoHS compliant pins used; ECF 326 B0 refers	AS
		A	30Jul02	ORIGINAL (was L07355A)	
Format	A4	REV	Date	Revision description	By
Die n.	MATERIAL Aluminium EN AW-6060			DRAWING n.	BC092
Factor	GENERAL TOLERANCES Extrusion UNI3879		Vis. n.	405130G	Description: HTSK-AL-0S172-25,4-B-PINS-ML73 6098 STD CONF500-BC092 B
Perim.	Machining UNI2768 m		Drawn	M. Calanchi	
Area	FINISH BLACK ANODIZATION		Check		
Weight					