

Heatsink Extruded

High power dissipation, vertical mounting extruded heatsink with solderable fixing pins and notched base. Pre-drilled for a single TO218/220/247 package or via clip available separately.

Product Features:

- Choice of thermal resistance
- Low thermal resistance
- Solderable mounting pins
- Pre-drilled mounting holes
- Black anodize finish

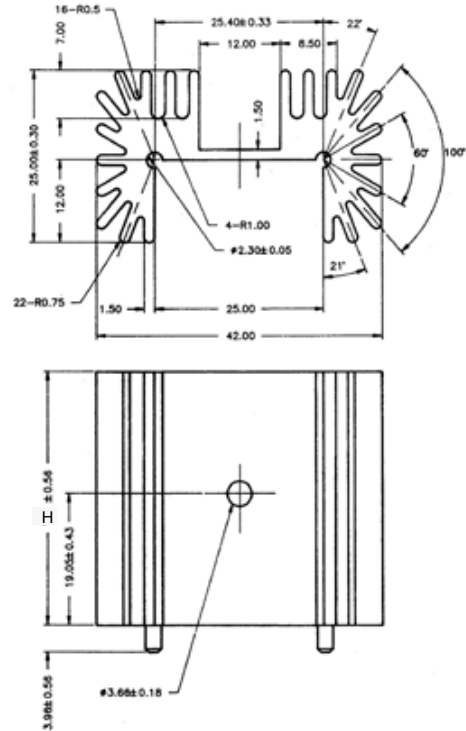
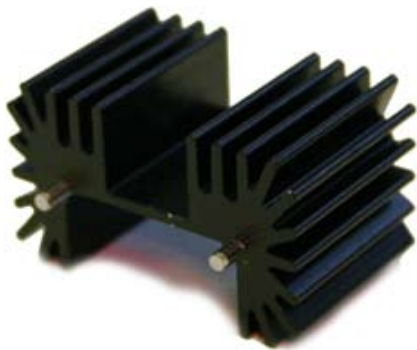

Mfg Part No:	Thermal Resistance:	Height (mm):	Device Mtg:
MC33268	5.6°C/W	25.4	Mounting Hole or Clip 3
MC33269	4.4°C/W	38.1	Mounting Hole or Clip 3
MC33270	3.3°C/W	50.8	Mounting Hole or Clip 3
MC33271	2.7°C/W	63.5	Mounting Hole or Clip 3

Mfg Part No:	Description:
MC33295	Clip 3

Clip 3

