

## NOTES

BUILT TO MEET THE REQUIREMENTS OF INDUSTRIAL AND COMMERCIAL USE. ALL METAL HOUSING—TOUGH EXTRUDED ALUMINUM CASE WITH BLACK POWDER-COATED STEEL COVER. HEAVY-DUTY CORD - 14/3 SJTW WIRE FOR EXTREME TEMPERATURE RANGES. INTEGRAL MOLDED PLUG AVAILABLE IN STRAIGHT-BLADE (NEMA 5-15P) OR TWIST-LOCK (NEMA L5-15P) CONFIGURATIONS. SEPARATE MOUNTING FEET WITH KEYHOLE SLOTS PROVIDE FOR WORK STATION MOUNTING IF DESIRED. COMES WITH LIGHTED RED PILOT LIGHT TO INDICATE POWER ON. INCLUDES 15A, 125VAC CIRCUIT BREAKER TO PREVENT ACCIDENTAL LINE OVERLOAD. CSA CERTIFIED, UL 1363 LISTED.

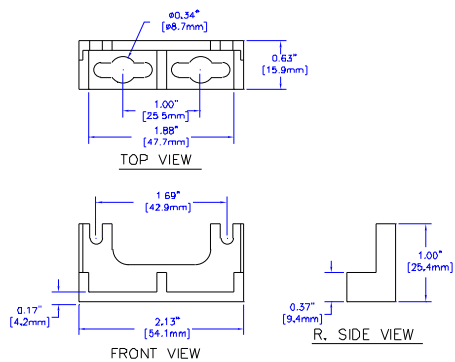

MOUNTING FEET DETAIL

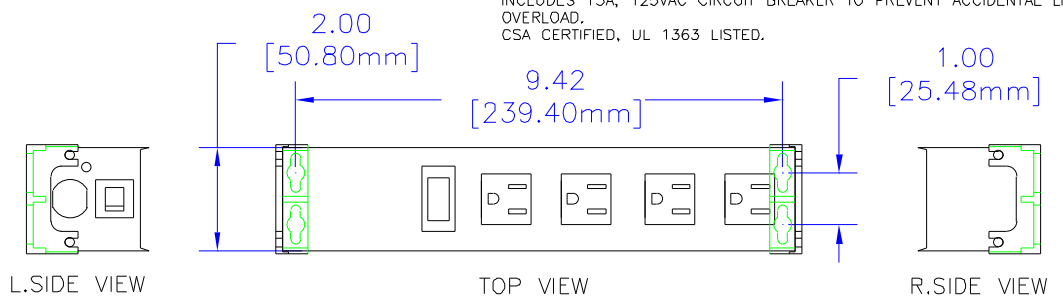
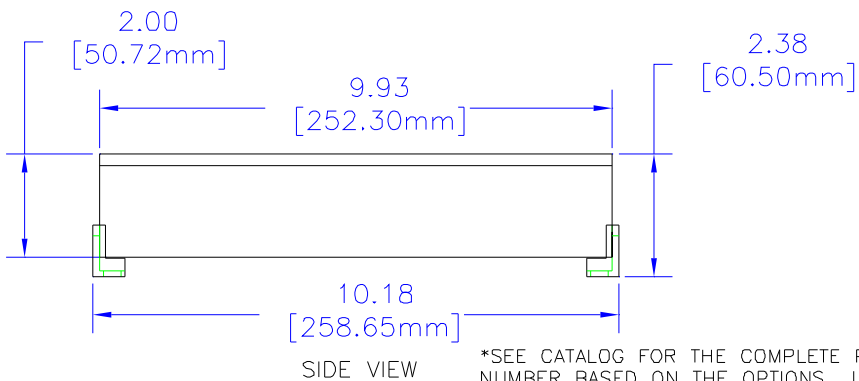

\*SEE CATALOG FOR THE COMPLETE PART NUMBER BASED ON THE OPTIONS LISTED IN THE NOTE SECTION

UNLESS OTHERWISE SPECIFIED  
DIMENSIONS ARE IN INCHES  
FRACTIONS  
DECIMALS  
DIMS  
ANGLES  
TOLERANCES  
DIMENSIONS OF THIS DRAWING ARE FOR INFORMATION ONLY AND DO NOT CONSTITUTE A CONTRACT FOR SUPPLY OF ANY PRODUCT. THE MANUFACTURER'S PRODUCT SHOULD BE REFERRED TO FOR THE MOST CURRENT INFORMATION FROM HAMMOND MANUFACTURING



HAMMOND  
MANUFACTURING

WEB: WWW.HAMMONDMFG.COM

FILE  
HAMMOND INDUSTRIAL  
GRADE POWER STRIPS  
DRAWN BY MJM DATE 02/09/01  
SCALE PAGE 1 OF 1  
PART NUMBER  
1584T4\*\*\*\*